



# Sensor Selector Guide: by Application by Product Type



Acceleration  
Force  
Pressure





# ABOUT US

## Introduction



Michael R. Change,  
President

### Data That Drives Innovation!

Welcome to the second edition of the Dytran Sensor Selector Guide. The Guide is organized in two parts – by Application and by Product Configuration. Our goal is to help you select Dytran sensors for innovative product development, testing, and validation solutions without having to sort through the entire product line. Chose from a wide variety of sensors for engineering development, test lab dynamics, reliability, end-of-line testing, machinery Condition-Based Maintenance (CBM), flight test, and many more fields - quickly and efficiently.

Dytran engineers utilize piezoelectric and variable capacitance DC-MEMS technologies to design sensors that are uniquely suited to environments from the test lab to the test track to outer space. When you need critical data, Dytran will find a way!

Contact us today or visit [www.dytran.com](http://www.dytran.com) to learn more about how Dytran sensors capture *data that drives innovation!*

### About Dytran

- Manufacturing System Registered ISO9001:2008 and AS9100C in accordance with the requirements of AS9104A
- Calibration System Registered ISO/IEC 17025:2005 and ANSI/NCCL Z540-1-1994
- 160 employees, 35,000 square foot manufacturing facility
- Dytran products are Made in U.S.A.

### Find out about these exciting new Customer Benefits Programs!

- Sensor Select 100™ Inventory Stocking Program with Lifetime Warranty
- Sensor Select 100™ Total Customer Satisfaction Money Back Guarantee
- NEW 5-Year Standard Product, 2-Year Modified Product, 1- Year Cable and Accessories Warranty
- The Quad™ Sensor Educational Donations
- Sensor Exchange™ Qualified Trade-In Program

Dytran has been known for state of the art piezoelectric sensors for the last 35 years. We have become industry leaders in automotive, aviation, commercial test and space applications. Over the last fifteen years Dytran is gaining an excellent reputation for both standard and custom MEMS based DC accelerometers.

Solving customer problems with the thoughtful application of these diverse technologies is what we do. We are proud to say the next generation technology of tomorrow is continuing to emerge from the Dytran team. Thanks to all of our dedicated customers around the world for helping us to make the best sensors possible. We have truly enjoyed the partnership over all these years. Stay tuned – the best is yet to come!



Dave Change,  
V.P., Technical Director

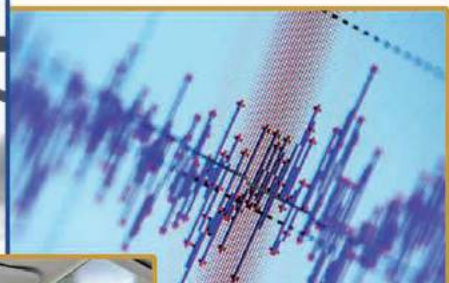



# ABOUT THIS GUIDE

## Organized By:

**Application:** The first part of this guide groups together the most popular products recommended to our customers within the following industry segments:

Application Area/Industry	Page(s)
Environmental Test Lab.....	4-7
Automotive Test and NVH.....	8-11
Modal and Structural Analysis.....	12-15
HUMS and Condition Based Maintenance (CBM).....	16-17
Flight Test.....	18-19
MEMS-DC Response Accelerometers.....	20-21
Turbine Engine, Test Cell, and High Temperature.....	22-23
Space Vehicle, Ground & Flight Testing.....	24-25
Extreme Environments.....	26-27
Industrial Machinery Condition Based Maintenance (CBM).....	28-29
Dynamic Force & Pressure Sensors.....	30-31
Electronics/Signal Conditioning.....	32-33
How to Get More Information & How to Read the Spec Tables.....	34-35

**Product Type:** The second part of the Guide groups the products into easy-to-read tables for side-by-side comparison of all products in the following configurations/types:

Product Configuration	Page(s)
Piezoelectric Accelerometers.....	36-51
DC MEMS Accelerometers.....	52-53
Accelerometer Mounting Accessories.....	54-55
Piezoelectric Pressure Sensors.....	56-57
Pressure Sensor Mounting Accessories.....	57
Piezoelectric Force Sensors.....	58-59
Impulse Hammers.....	60
Impulse Hammer Accessories.....	61
Electronics.....	61-63
Cables.....	64-66
Customer Benefits.....	67

## For More Information

Call us  
for application information  
at **818.700.7818**



Visit our website [www.dytran.com](http://www.dytran.com) for full specifications, pricing, quotes, and check out our online Store featuring over 100 models in stock for immediate delivery.

**Search the website:** Type any model number in this Guide into the Quick Search box to get full specifications!

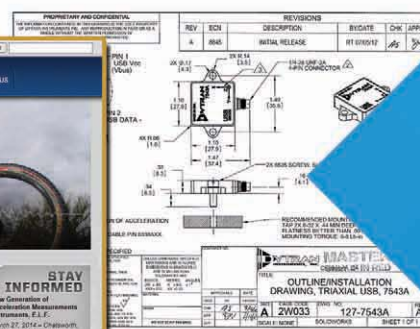
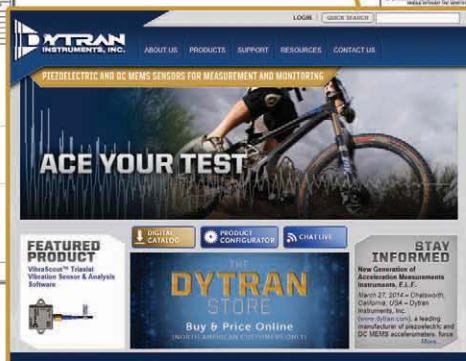
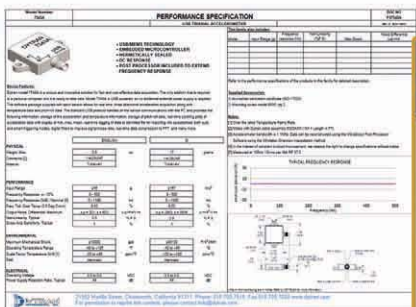
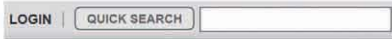

[www.dytran.com](http://www.dytran.com)



# ENVIRONMENTAL TEST LAB

The world of the dynamics test lab encompasses many aspects of physical properties testing including vibration/acceleration response, HALT/HASS, mechanical shock, fatigue, drop testing, seismic motions, and product reliability testing to DO-160 and other standards. Dytran products are used extensively by test lab managers and technicians to provide the data you need to complete test plans with confidence, on schedule.

## Shaker Control

Sensors in this category are characterized by high sensitivity, low noise, and wide frequency range. Dytran test lab sensors offer the excellent high and low frequency response, good thermal stability, and rugged reliability required to get maximum performance out of your electrodynamic, mechanical, hydraulic, pneumatic, 4-poster, or 6DoF shakers.

### Series 3056D: Base Isolated

Available in 8 ranges and TEDS: 10g, 25g, 50g, 100g, 250g, 500g, 1,000g, 5,000g

- Sensitivities (mV/g): 500, 200, 100, 50, 20, 10, 5, 1
- 10-32 axial connector, 10-32 tapped hole
- 10 grams
- Hermetically sealed
- Eliminates ground loops
- -60 to +250°F (-51 to +121°C)
- IEPE



### Series 3055D: Base Isolated

Available in 6 ranges and TEDS: 10g, 25g, 50g, 100g, 250g, 500g

- Sensitivities (mV/g): 500, 200, 100, 50, 20, 10
- 10-32 radial connector, 10-32 tapped hole
- 10 grams
- Hermetically sealed
- Eliminates ground loops
- -60 to +250°F (-51 to +121°C)
- IEPE



### Model 3030B5: For Thermal Chambers

- 10 mV/g sensitivity, 500g range
- 5 to 10,000 Hz ( $\pm 5\%$ )
- 10-32 axial connector
- 10-32 stud mount
- 6.8 grams
- -148 to +250°F (-100 to +121°C)
- IEPE
- For use in thermally active environments



### Model 3030B4: Ultra Rugged 10 mV/g

- 10 mV/g sensitivity, 500g range
- 2 to 10,000 Hz ( $\pm 5\%$ )
- 10-32 axial connector
- 10-32 stud mount or adhesive mount
- 6.8 grams
- -148 to +250°F (-100 to +121°C)
- IEPE



### Series 3143D: Low Profile Triaxial Accelerometer

Available in 3 ranges: 50g, 100g, 500g

- Sensitivities (mV/g): 100, 50, 10
- 4-pin 1/4-28 radial connector
- Thru hole mount
- 14 grams
- Case isolated
- 360° cable orientation
- Low profile
- -60 to +185°F (-51 to +85°C)
- IEPE



### Series 7705A : Extended Low Frequency Response Accelerometer (ELF™)

Available in 3 ranges: 20g, 40g, 200g

- Sensitivities (mV/g): 100, 50, 10
- 0 to 10,000 Hz frequency range ( $\pm 10\%$ )
- 4-pin M4.5 x 0.35 radial connector
- 10-32 tapped hole
- 15 grams
- -60 to +250°F (-51 to +121°C)
- Hybrid design
- Dual mode technology: incorporates AC and DC into one sensor



## High Temperature Environments

Charge mode (PE) sensors are used in situations where elevated temperatures exceed the limits of IEPE internally amplified sensors. Accelerometers in this section can be used very reliably in temperatures up to 500 degrees F when paired with laboratory charge amplifiers, or with miniature in-line charge amplifiers in conjunction with IEPE power supplies.

### Model 3049D: High Temperature, Low Mass

- 5.8 pC/g sensitivity, 8,000 Hz upper frequency range ( $\pm 5\%$ )
- 10-32 axial connector, Adhesive mount or 10-32 stud mount
- Lightweight, 3 grams, base isolated
- -100 to +350°F (-73 to +177°C)
- Charge mode



### Series 3122C: High Temperature Accelerometer

Available in 2 ranges: +375°F (+191°C); +500°F (+260°C)

- Sensitivities (pC/g): 50, 15
- 5,000 Hz upper frequency range ( $\pm 8\%$ )
- 10-32 radial connector
- 10-32 tapped hole
- Small size, 25 grams
- -60 to +375°F (-51 to +190°C)
- 500°F (260°C) version available
- Charge mode
- Top connector version available: 3152C

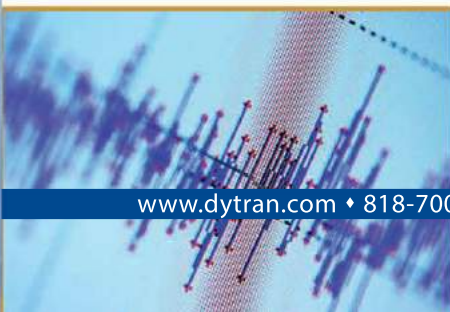



## Product Response



Sensors used for test article response under vibration, shock, or other excitation must be very lightweight so as not to “mass load” the test article and alter its dynamic behavior, and they must be physically small in size in order to fit into tight spaces or critical locations of interest. This is especially important when dealing with today’s consumer products such as mobile phones, tablets, wearables, and other miniature electronics products.

### Series 3224A: Ultra Miniature, Tight Locations

Available in 4 ranges: 500g; 1,000g; 2,500g, 5,000g

- Sensitivities (mV/g): 10, 5, 2, 1
- 3-foot (0.9-meter) integral cable
- Adhesive mount
- 0.2 grams
- Titanium
- -60 to +300°F (-51 to +149°C)
- Ultra miniature teardrop design
- IEPE



### Series 3133A: Ultra Mini Triaxial Accelerometer

Available in 4 ranges: 500g, 1,000g, 2,500g, 5,000g

- Sensitivities (mV/g): 10, 5, 2, 1
- Axis 1 & 2: 0.25 to 7,000 Hz frequency range ( $\pm 10\%$ )
- Axis 3: 0.25 to 10,000 Hz frequency range ( $\pm 10\%$ )
- 3-foot integral cable
- Adhesive mount
- 0.8 grams
- Ultra miniature design
- -60 to +250°F (-51 to +121°C)
- IEPE



### Series 3274A: Adhesive Mount, Isolated with TEDS

Available in 3 ranges: 200g; 500g; 1,000g

- Sensitivities (mV/g): 25, 10, 5
- 1 to 10,000 Hz ( $\pm 10\%$ )
- 3-foot (0.9-meter) removable cable
- Adhesive mount
- 2 grams
- Case isolated, teardrop style
- Ultra miniature teardrop design
- IEEE 1451.4 TEDS capabilities
- -60 to +250°F (-51 to +121°C)
- IEPE



### Series 3032A: Adhesive Mount

Available in 2 ranges: 500g, 1,000g

- Sensitivities (mV/g): 10, 5
- 1 to 10,000 Hz ( $\pm 10\%$ )
- 18-inch integral cable
- Adhesive mount
- 1.5 grams
- Titanium
- Low profile
- -60 to +250°F (-51 to +121°C)
- IEPE



### Series 3035B: Lightweight, Side Connector

Available in 4 ranges: 50g, 100g, 500g, 1,000g

- Sensitivities (mV/g): 100, 50, 10, 5
- 5-44 radial connector
- 5-40 stud mount
- 2.5 grams
- IEPE
- -60 to +250°F (-51 to +121°C)
- Adhesive mount version available



### Series 3145A: Lightweight, Top Connector

Available in 3 ranges: 50g, 500g, 1,000g

- Sensitivities (mV/g): 100, 10, 5
- 5-44 axial connector
- 5-40 stud mount
- 2.3 grams
- Miniature design
- IEPE
- -60 to +250°F (-51 to +121°C)
- Adhesive mount version available



### Model 3225E: High Temperature Accelerometer

- 1.8 pC/g sensitivity
- 10,000 Hz upper frequency range ( $\pm 10\%$ )
- Integral 3-foot cable assembly
- Adhesive mount
- 0.6 grams
- Ultra miniature teardrop design
- -60 to +350°F (-51 to +177°C)
- Charge mode



Use with:

### 4751B Series: In-Line Charge Amplifier

Available in 4 ranges: and TEDS 100 pC; 500 pC; 5,000 pC; 50,000 pC

- Sensitivities (mV/pC): 50, 10, 1, 0.1
- 10-32 jack to 10-32 jack
- 25 grams

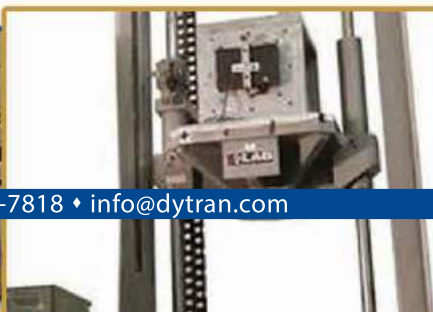



# ENVIRONMENTAL TEST LAB

## ESS/HALT/HASS

Dytran products have been a mainstay in the ESS/HALT/HASS laboratory since the early 1980's. Years of experience have produced products in this section that are time-tested and proven in the toughest long-term test and evaluation environments.

### Model 3030B5H: Miniature, High Temperature Accelerometer

- 10 mV/g sensitivity, 500g range
- 5 to 10,000 Hz ( $\pm 5\%$ )
- 10-32 axial connector
- 10-32 stud mount
- 6.8 grams
- -60 to +325°F (-54 to 163°C)
- IEPE



### Model 5310M1: High Temperature System, 500°F

- 10 mV/g sensitivity, 500g range
- 10-foot removable cable assembly
- 10-32 stud mount
- 6.8 grams (accelerometer weight)
- 40 grams (charge amplifier weight)
- -100 to 500°F (-73 to +260°C) (accel)
- -50 to 185°F (-46 to +185°C) (charge amp)
- System includes (1) model 3030C1 charge mode accelerometer, (1) model 6019B10 low noise cable assembly (10-32 to BNC), (1) model 4705M13 in-line charge amplifier
- IEPE



### Series 3023A: Triaxial Accelerometer

Available in 3 ranges and TEDS: 500g; 1,000g; 5,000g

- Sensitivities (mV/g): 10, 5, 1
- 4-pin 1/4-28 radial connector
- Adhesive mount
- 3 grams, lightweight
- -60 to +250°F (-51 to +121°C)
- IEPE
- High temperature version available: 3023AH



### Model 3045A: Cryogenic Accelerometer

- 5 mV/g sensitivity, 1,000g range
- 4.8 to 1,800 Hz frequency range ( $\pm 5\%$ )
- 10-32 axial connector
- 1/4-28 stud mount
- 20 grams, Case isolated
- -320 to +300°F (-196 to +148°C) operation
- Two-pole low pass filter
- Stable MOSFET amplifier technology
- IEPE



## Triaxial IEPE Accelerometers for X,Y,Z Vibration

Measure dynamic vibration and low-level shock events in three orthogonal axes. Ideal for structural and rigid body vibration studies and 6DoF shaker applications.

### Series 3273A: Extended Low Frequency

Available in 3 ranges and TEDS: 50g, 100g, 500g

- Sensitivities (mV/g): 100, 50, 10
- 0.5 to 3,000 Hz frequency range ( $\pm 5\%$ )
- 4-pin 1/4-28 radial connector
- Adhesive mount, 2.7 grams, miniature design
- Extended low frequency response
- Low noise JFET electronics, IEPE
- -60 to +225°F (-51 to +107°C)



### Series 3233AT: Thru Hole

Available in 2 ranges and TEDS: 5g; 1,000g

- 1,000 mV/g sensitivity
- Axis 1 & 2: 0.4 to 3,000 Hz frequency range ( $\pm 10\%$ )
- Axis 3: 0.4 to 6,000 Hz frequency range ( $\pm 10\%$ )
- 4-pin 1/4-28 radial connector
- Thru hole mount, 30 grams, base isolated
- 360° cable orientation
- Ultra high sensitivity, IEPE
- -60 to +200°F (-51 to +90°C)



### Series 3053B: Case Isolated

Available in 2 ranges: 500g, 1,000g

- Sensitivities (mV/g): 10, 5
- 2 to 5,000 Hz frequency range ( $\pm 10\%$ )
- 4-pin 1/4-28 radial connector
- Adhesive mount or 10-32 tapped hole
- 6 grams, triaxial, IEPE
- -60 to +250°F (-51 to +121°C)



### Series 3093B: Triaxial Accelerometer

Available with TEDS

- 100 mV/g sensitivity, 50g range
- 4-pin 1/4-28 radial connector
- Adhesive mount or 10-32 tapped hole
- 10 grams
- Case isolated
- Low profile, IEPE
- -60 to +225°F (-51 to +121°C)



### Series 3263A: Triaxial Accelerometer

Available in 3 ranges and TEDS: 50g, 100g, 500g

- Sensitivities (mV/g): 100, 50, 10
- 4-pin 1/4-28 radial connector
- 4-40 tapped hole
- 5.6 grams
- Low noise
- -60 to +250°F (-51 to +121°C)
- IEPE



### Series 3343A: Triaxial Accelerometer

Available in 3 ranges: 500g; 1,000g; 2,500g

- Sensitivities (mV/g): 10, 5, 2
- 1.2 to 5,000 Hz frequency range ( $\pm 15\%$ )
- 4-pin M4.5 x 0.35 radial connector
- Adhesive mount
- 2.4 grams, miniature design
- Hermetic
- -60 to +250°F (-51 to +121°C)
- IEPE

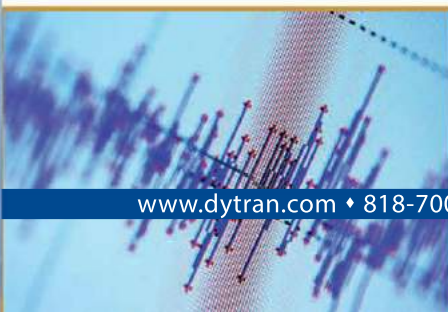



## General Purpose



Products in this section are suited for day-to-day use in the test lab. They are compatible with IEPE power supplies available in data acquisition cards, shaker control systems, or with any IEPE power supply available in the lab.

### Model 3220E : Ring Style

- 10 mV/g sensitivity, 500g range
- 1 to 5,000 Hz ( $\pm 5\%$ )
- 5-44 radial connector
- $\varnothing 0.09$ -inch (2.36-millimeter) thru hole mount
- 2.7 grams
- Base isolated
- $360^\circ$  cable orientation
- -60 to  $+250^\circ\text{F}$  (-51 to  $+121^\circ\text{C}$ )
- IEPE



### Model 3215M1: Ring Style

- 10 mV/g sensitivity, 500g range
- 1 to 10,000 Hz frequency range ( $\pm 5\%$ )
- 10-32 radial connector
- $\varnothing 0.19$  thru hole mount
- 10 grams
- Hermetically sealed
- Case isolated
- $360^\circ$  cable orientation
- -60 to  $+300^\circ\text{F}$  (-51 to  $+149^\circ\text{C}$ )
- IEPE



### Series 3256A: Non-isolated, Ultra Rugged

Available in 6 ranges and TEDS: 10g, 25g, 50g, 100g, 250g, 500g

- Sensitivities (mV/g): 500, 200, 100, 50, 20, 10
- 10-32 axial connector
- 10-32 tapped hole
- 10 grams
- Hermetically sealed
- Low noise JFET electronics
- -60 to  $+250^\circ\text{F}$  (-51 to  $+121^\circ\text{C}$ )
- IEPE



### Model 3334A1: Cryogenic Accelerometer

- 10 mV/g sensitivity, 500g range
- 1 to 10,000 Hz ( $\pm 5\%$ )
- 5-44 radial connector
- 5-40 stud mount
- 2 grams
- IEPE
- Miniature
- -320 to  $+250^\circ\text{F}$  (-196 to  $+121^\circ\text{C}$ )



### Series 3211A: General Purpose Accelerometer

Available in 2 ranges: 50g, 500g

- Sensitivities (mV/g): 100, 10
- 1 to 10,000 Hz frequency range ( $\pm 5\%$ )
- 10-32 radial connector
- $\varnothing 0.17$  thru hole mount
- 10 grams
- Hermetically sealed
- Base isolated
- $360^\circ$  cable orientation
- Low noise JFET electronics
- -67 to  $+250^\circ\text{F}$  (-51 to  $+121^\circ\text{C}$ )
- IEPE



### Series 3214A: Cubic Design

Available in 3 ranges and TEDS: 10g, 50g, 500g

- Sensitivities (mV/g): 500, 100, 10
- 1 to 10,000 Hz frequency range ( $\pm 5\%$ )
- 10-32 radial connector
- 10-32 tapped hole
- 11 grams
- Hermetically sealed
- Low noise JFET electronics
- Unique cubic design, mounts on (5) sides
- -60 to  $+250^\circ\text{F}$  (-51 to  $+121^\circ\text{C}$ )
- IEPE



### Series 3255A: Non-isolated, Ultra Rugged

Available in 4 ranges: 25g, 50g, 250g, 500g

- Sensitivities (mV/g): 200, 100, 20, 10
- 10-32 radial connector
- 10-32 tapped hole
- 10 grams
- Hermetically sealed
- Low noise JFET electronics
- -60 to  $+250^\circ\text{F}$  (-51 to  $+121^\circ\text{C}$ )
- IEPE



### Model 3100D24: High Sensitivity, 1V/g

Available with TEDS

- 1,000 mV/g sensitivity, 5g range
- 1 to 1,000 Hz frequency range ( $\pm 5\%$ )
- 10-32 radial connector
- 10-32 tapped hole
- 55 grams
- Hermetically sealed
- Case isolated
- High sensitivity
- -60 to  $+250^\circ\text{F}$  (-51 to  $+121^\circ\text{C}$ )
- IEPE

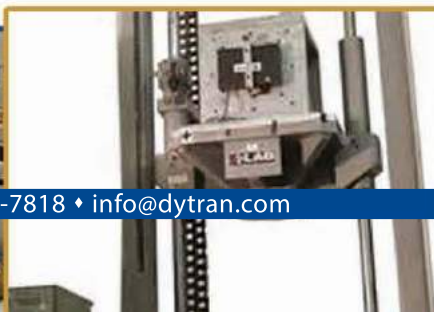



# AUTOMOTIVE TEST AND NVH

Dytran offers a comprehensive line of AC and DC sensors for internal and external NVH in full-vehicle, component, and sub-assembly tests. Improve vehicle reliability, durability, safety, and ride quality with Dytran automotive test sensors.

## Noise, Vibration and Harshness (NVH)



Find the sources of squeaks, rattles, and structure-borne noise with Dytran single axis and triaxial accelerometers. Miniature accelerometers work well on mirrors, panels, and other lightweight structures, while high temperature IEPE triaxial accelerometers can be mounted in the engine compartment near intake manifolds and exhaust systems to look for contributions to unwanted noise and vibration.

### Series 3023A: Triaxial Accelerometer

Available in 3 ranges and TEDS: 500g, 1,000g, 5,000g

- Sensitivities (mV/g): 10, 5, 1
- Lightweight, 3 grams
- Adhesive mount
- -60 to +250°F (-51 to +121°C)
- High temperature version available: 3023AH
- IEPE



### Model 3093M27: High Temperature Triaxial Accelerometer

- 500g range, 10 mV/g
- Lightweight, 3 grams
- Low profile
- Case isolated
- -60 to +320°F (-51 to +160°C)
- IEPE



### Series 3225E/F: Miniature Accelerometer

- Sensitivities; 10 mV/g, 1 mV/g, 1.8 pC/g
- 0.6 grams
- 10,000 Hz upper frequency range ( $\pm 10\%$ )
- Adhesive mount
- Available with choice of removable or integral cable
- -60 to +350°F (-51 to +177°C)
- IEPE and charge mode options available
- Base isolated design available



### Series 3023AH: High Temperature Triaxial Accelerometer

Available in 3 ranges and TEDS: 500g, 1,000g, 5,000g

- Sensitivities (mV/g): 10, 5, 1
- +325°F (+163°C) operation
- Lightweight, 3 grams
- Adhesive mount
- -60 to +325°F (-51 to +163°C)
- IEPE



## Road Load, Durability and Ride Quality



Dytran sensors put objective data behind subjective ride quality impressions under any load condition. DC-MEMS sensors provide excellent phase response between measurement points. Rugged, hermetically sealed designs survive tough 4-poster shaker testing. Innovative ELF™ Extended Low Frequency technology combines DC-MEMS with IEPE piezo for the widest frequency response in the industry, 0-10kHz.

### Series 7600B: High Precision MEMS Accelerometer

Available in 6 ranges: 5g, 10g, 25g, 50g, 100g, 200g

- Sensitivities (mV/g): 100, 50, 20, 10, 5, 2.5
- 3.6 grams
- MEMS technology
- Hermetically sealed
- Differential mode
- -40 to +248°F (-40 to +120°C)
- +9 to +26 VDC power
- VC technology powered by strain gage amplifiers



### Series 7603B: High Precision Triaxial MEMS Accelerometer

Available in 8 ranges: 2g, 5g, 10g, 25g, 50g, 100g, 200g, 400g

- Sensitivities (mV/g): 250, 100, 50, 25, 10, 5, 2.5, 1.25
- 35 grams
- Ultra low noise
- Hermetically sealed
- Differential mode
- -40 to +250°F (-40 to +121°C)
- +9 to +26 VDC power
- VC technology powered by strain gage amplifiers



### Series 7705A: Extended Low Frequency (ELF™) Accelerometer

Available in 3 ranges: 20g, 40g, 200g

- Sensitivities (mV/g): 10, 50, 100
- 0 to 10,000 Hz frequency range ( $\pm 10\%$ )
- 15 grams, hybrid design
- Dual mode technology: incorporates AC and DC sensing elements into one sensor
- -60 to +250°F (-51 to +121°C)
- 5-28 VDC power



### Series 7503A: High Precision Triaxial MEMS Accelerometer

Available in 7 ranges: 2g, 5g, 10g, 25g, 50g, 100g, 200g

- Sensitivities (mV/g): 1,000; 400; 200; 80; 40; 20; 10
- 13 grams
- Ultra low noise
- Hermetically sealed
- Differential mode
- -40 to +250°F (-40 to +121°C)
- +9 to +26 VDC power



### Series 7500A: High Precision MEMS Accelerometer

Available in 8 ranges: 2g, 5g, 10g, 25g, 50g, 100g, 200g, 400g

- Sensitivities (mV/g): 1,000; 400; 200; 80; 40; 20; 10
- 13 grams
- Ultra low noise
- Hermetically sealed
- Differential mode
- -67 to +257°F (-51 to +125°C)
- +9 to +26 VDC power



### Model 2013D: IEPE Sound Pressure Sensor

- 2,000 mV/psi sensitivity, 2.5 psi range
- 24 grams
- Fast rise time, High natural frequency
- Hermetically sealed
- 3/4-16 mounting thread adaptor
- Airbag deployment pressure
- -60 to +250°F (-51 to +121°C)
- Cabin noise





## Brake, Transmission and Powertrain Testing

Sensors in this category are used in test cell environments to evaluate, improve, and smooth rotating components and assemblies to eliminate unwanted oscillations/imbbalances/gear mesh noise that can affect the full vehicle.

### Model 3443C: High Temperature Triaxial Accelerometer

- 2.7 pC/g sensitivity
- 10,000 Hz upper frequency range
- 10 grams
- Low profile
- Isolated 10-32 outputs for use with low noise cable
- -94 to +500°F (-70 to +260°C)
- Charge mode



Use with:  
Series 4753B: In-Line Charge Amplifier

### Series 3224A: Ultra Miniature Accelerometer

Available in 4 ranges: 500g, 1,000g, 2,500g, 5,000g

- Sensitivities (mV/g): 10, 5, 2, 1
- 0.3 to 20,000 Hz ( $\pm 5\%$ )
- 0.2 grams
- Ultra miniature teardrop design
- World's smallest IEPE 10mV/g accelerometer
- -60 to +300°F (-51 to +149°C)
- IEPE



### Series 3133A: Ultra Miniature Triaxial Accelerometer

Available in 4 ranges: 500g, 1,000g, 2,500g, 5,000g

- Sensitivities (mV/g): 10, 5, 2, 1
- 0.8 grams
- Miniature cubic design
- World's smallest triaxial
- -60 to +250°F (-51 to +121°C)
- High temp version available
- IEPE



### Model 3310A: High Temperature Accelerometer

- 1.2 pC/g sensitivity
- 7,000 Hz upper frequency range ( $\pm 5\%$ )
- 1.8 grams
- Ultra miniature teardrop design
- -60 to +500°F (-51 to +260°C)
- Base isolated
- Charge mode



## Modal Analysis

Accelerometers used for modal analysis of frames, panels, and body-in-white studies must be lightweight, exhibit very low amplifier noise, and they must have excellent low frequency response. Dytran modal sensors assure a clean response signal and their small size and low mass avoids structural mass loading effects. Go to the Modal Analysis section of this Guide for a complete selection of Dytran modal analysis accelerometers, impulse hammers, driving point sensors.

### Series 3333A: Triaxial Accelerometer

Available in 3 ranges and TEDS: 50g, 100g, 500g, 5,000g

- Sensitivities (mV/g): 100, 50, 10, 1
- 0.31 to 10,000 Hz frequency range ( $\pm 15/-10\%$ )
- 2.3 grams, miniature connector
- Low noise JFET electronics: 0.0007g resolution
- Case isolated version available
- -60 to +250°F (-51 to +121°C)
- IEPE



### Series 3273A: Triaxial Accelerometer

Available in 3 ranges and TEDS: 50g, 100g, 500g

- Shared driving point sensor
- Sensitivities (mV/g): 100, 50, 10
- 0.5 to 3,000 Hz frequency range ( $\pm 5\%$ )
- Extended low frequency response
- 2.7 grams
- Low noise JFET electronics
- -60 to +225°F (-51 to +107°C)
- IEPE



### Models 3225M23/24: Miniature Accelerometer

Available in 2 ranges and TEDS: 50g, 100g

- Sensitivities (mV/g): 100, 50
- 2 to 10,000 Hz ( $\pm 10\%$ )
- 1 gram
- Ultra miniature teardrop design
- High sensitivity
- Removable cable
- -60 to +220°F (-51 to +104°C)
- IEPE



### Model 5860B: Impedance Head

- Simultaneously measures force and acceleration
- Shaker driving point sensor
- 100 mV/g sensitivity
- 60 grams
- 10-32 tapped hole
- -100 to +250°F (-73 to +121°C)
- IEPE



### Model 5800B4: Dynapulse™ Impulse Hammer

- 10 mV/LbF sensitivity
- 100 gram headweight
- 500 lbf range
- 1,000 lbf maximum force
- BNC connector
- Optional TEDS
- IEPE



### Model 5800SL: "Super Light" Impulse Hammer

- For high frequency excitation
- 100 mV/LbF sensitivity
- 50 lbf range
- 10-32 connector
- 2 gram head weight
- IEPE



See pg. 15 to view our complete line of impulse hammers

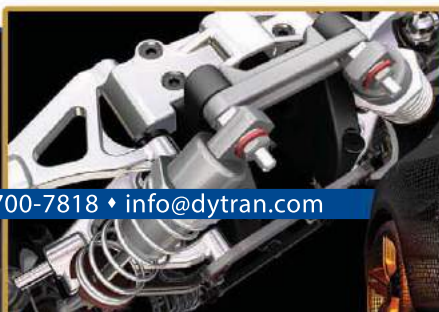



# AUTOMOTIVE TEST AND NVH

## Exhaust System Testing

Automotive exhaust systems are a major source of vibration and noise and must be characterized to eliminate unwanted NVH inputs to the vehicle structure and to passengers. Dytran high temperature accelerometers can be mounted anywhere on the system, from the manifold to the tailpipe, to measure frequencies and amplitudes through the operating temperature range of the system.

### Model 3316M3: Ultra High Temperature Accelerometer

- -60 to +1,000°F (-51 to +538°C)
- 1 to 2 pC/g sensitivity
- 10,000 Hz upper frequency range ( $\pm 10\%$ )
- 6 grams
- Also available with 10-32 tapped hole
- Miniature cubic design
- Patented Silver Window™ Technology
- Charge mode



### Model 3335C: Extreme High Temperature Accelerometer

- -60 to +1,200°F (-51 to +649°C)
- 1 to 2 pC/g sensitivity
- 5,000 Hz upper frequency range ( $\pm 10\%$ )
- 20 grams
- 10-32 screw
- Charge mode
- Industry smallest – lowest mass – lowest cost – 650 C accel



## Whole-Body and Hand-Arm Vibration Measurements

Study Whole Body Vibration (WBV) and Hand-Arm Vibration (HAV) to validate occupational health and safety standards or ride quality characteristics in automobiles, buses, farm & heavy equipment, trucks, and construction vehicles. Dytran low noise, low frequency accelerometers are ideal for WBV frequencies in the 1-8 Hz range, and for HAV frequencies in motorcycles and mountain bikes up to the highest limit of structure-borne resonance frequencies.

### Series 3097A: Miniature Accelerometer

Available in 3 ranges and TEDS: 10g, 50g, 500g

- Sensitivities (mV/g): 500, 100, 10
- 0.3 to 5,000 Hz ( $\pm 5\%$ )
- 4.3 grams
- Low noise
- Miniature cubic design allows for multi-faced mounting
- 5-40 tapped hole
- -60 to +200°F (-51 to +93°C)
- IEPE



### Series 3305A: Miniature Accelerometer

Available in 3 ranges: 10g, 50g, 500g

- Sensitivities (mV/g): 500, 100, 10
- 0.3 to 5,000 Hz ( $\pm 10\%$ )
- 3.7 grams
- Low noise JFET electronics
- Miniature cubic design
- Adhesive mount
- -60 to +200°F (-51 to +93°C)
- IEPE



### Model 3056B9: Filtered IEPE Accelerometer

- 10 mV/g sensitivity
- 1 to 10,000 Hz frequency range ( $\pm 15\%$ )
- 16 grams
- 10-32 screw
- Stud mount
- -67 to +257°F (-55 to +125°C)
- Mechanically and electrically filtered for high frequency and high energy survivability



### Model 3143D1T: Triaxial Accelerometer with TEDS

- 100 mV/g sensitivity, 50g range
- 0.4 to 3,000 Hz frequency range ( $\pm 5\%$ )
- 4-pin 1/4-28 radial connector
- Thru hole mount
- 15 grams
- Case isolated
- 360° cable orientation
- Low profile
- -60 to +185°F (-51 to +85°C)
- IEEE 1451.4 TEDS capabilities



### Model 5313A: Triaxial Seat Pad Accelerometer

- Measures three axis WBV inputs at operator or passenger seat locations
- 100 mV/g sensitivity, 50g range
- 0.5 to 3,000 Hz frequency range ( $\pm 5\%$ )
- 227 grams
- Conforms to ISO 8041
- -60 to +160°F (-51 to +71°C)
- IEPE

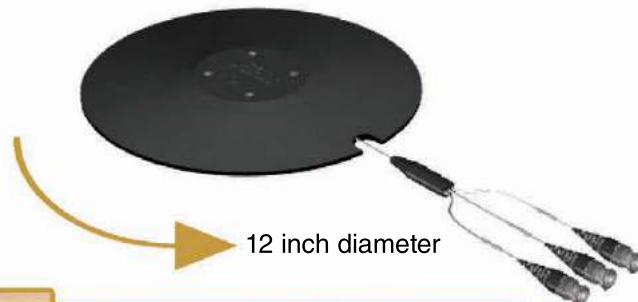

12 inch diameter





## Digital USB Powered



Dytran VibraScout™ accelerometers plug directly into your laptop or PC for instant acquisition of triaxial or 6DoF data; no external power supply or signal conditioning needed. It's the easiest, most convenient way to complete 3-axis and 6-axis vibration studies and to produce data for reports, all with your own computer! Go to our website for complete details and computer system requirements.

### System 5340: VibraScout™ Triaxial Vibration Sensor and Analysis Software

*The Dytran 7543B USB Digital Tri-axial Accelerometer combines a 3-Axis MEMS accelerometer with a microcontroller to create an intelligent sensor.*

#### Features:

- 16g range
- 4-pin 1/4-28 radial connector
- 17 grams (accelerometer)
- Three-directional vibration data acquisition
- Embedded microcontroller
- -40 to +185°F (-40 to +85°C)
- 3.8 to 6.0 VDC power
- Plugs directly into laptop or PC USB port



### System 5346A: VibraScout™ 6D USB Powered Triaxial Vibration Sensor and Analysis Software

*The VibraScout™ 6D is a USB compatible, "plug and play" portable, very affordable six degrees of freedom data acquisition system. Measure X,Y,Z acceleration, Roll, Pitch, Yaw and Temperature using a laptop or tablet with a USB port.*

#### Features:

- 14g range
- 4-pin 1/4-28 radial connector
- 13 grams
- Three-directional vibration data acquisition (Acceleration) and three-directional orientation data acquisition (Rotational)
- -40 to +185°F (-40 to +85°C)
- 3.8 to 6.0 VDC power



### System 4400A: VibraCorder™ Vibration Recorder and Analysis Software

*VibraCorder™ goes anywhere and everywhere to capture critical vibration data, solve problems, and move product development forward. Compact, lightweight, battery operated, environmentally sealed package fits into tight spaces.*

#### Features:

- Mounting: magnetic or screw
- Operates on 9 Volt battery
- Multiple recording regimes: Free run, triggered event, triggered free run, auto stop, etc.
- Several sampling rates available up to 3200 samples/second
- Environmentally sealed with IP67 rating
- -40 to 185°F (-40 to 85°C)
- Available in two ranges: +/-16g and +/- 200g
- Internal accelerometer

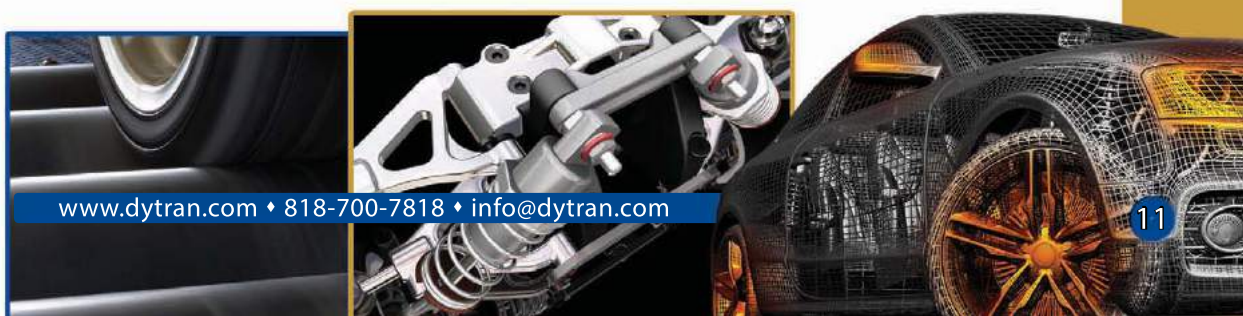
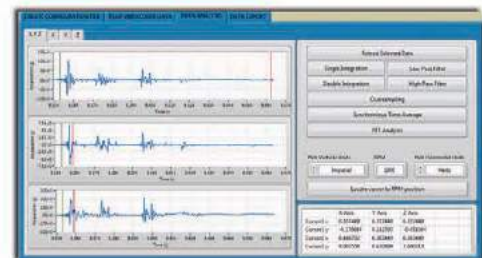



# MODAL AND STRUCTURAL ANALYSIS

Analyze and define the dynamic properties of structures with Dytran modal analysis sensors. The field of modal and structural analysis requires accelerometers that are designed to best suit the size of the structure vs. the applied excitation. The behavior of small structures must not be mass-loaded and altered by heavy response accelerometers, and large structures such as buildings, bridges, towers, and storage tanks need ultra-sensitive accelerometers to measure correspondingly smaller displacements. On the excitation side, Dytran offers the industry's broadest range of impulse hammers to cover almost any size test article, from small structures like turbine blades and castings to large structures like ships and airframes.

## Small Structures/Turbine Blades/Mounting Plates



Small structures resonate at higher frequencies and the quality of the measurement can be adversely affected by the mass of response accelerometers. Excessive mass can change the natural response of the structure or test article by imparting unwanted damping effects. It is critical when studying modal responses of small structures to select accelerometers of the lowest possible mass. The accelerometers in this section are among the lowest mass sensors in the industry, assuring a proper measurement response. When using impulse excitation, small, lightweight hammers with hard impact tips such as the Dytran 5800SL "Super Light" hammer are used to create the fast rise time, narrow pulse width energy required to excite high frequencies in the test article.

### Series 3224A: Ultra Low Mass

Available in 4 ranges: 500g; 1,000g; 2,500g, 5,000g

- Sensitivities (mV/g): 10, 5, 2, 1
- 0.3 to 20,000 Hz ( $\pm 5\%$ )
- 3-foot (0.9-meter) integral cable
- Adhesive mount
- 0.2 grams
- Titanium
- -60 to +300°F (-51 to +149°C)
- Ultra miniature teardrop design
- IEPE



### Model 3276A: Low Mass, Low Cost Accelerometer

- 5 mV/g sensitivity;  $\pm 1,000g$  range
- 2 to 10,000 Hz ( $\pm 5\%$ )
- Integral cable
- Flat surface for adhesive mount
- Ultra miniature, 0.6 grams
- Ideal low frequency response
- Low noise JFET electronics
- -60 to +300°F (-51 to +149°C)
- IEPE



### Series 3225F: Miniature Teardrop Accelerometer

Available in 2 ranges: 500g; 5,000g

- Sensitivities (mV/g): 10, 1
- 1.6 to 10,000 Hz ( $\pm 10\%$ )
- 3-foot (0.9-meter) removable cable
- Adhesive mount
- 0.6 grams
- Ultra miniature teardrop design
- -60 to +250°F (-51 to +121°C)
- IEPE



### Series 3274A: Miniature Accelerometer with TEDS

Available in 3 ranges: 200g; 500g; 1,000g

- Sensitivities (mV/g): 25, 10, 5
- 1 to 10,000 Hz ( $\pm 10\%$ )
- 3-foot (0.9-meter) removable cable
- Adhesive mount
- 2 grams
- Case isolated, teardrop style
- Ultra miniature teardrop design
- IEEE 1451.4 TEDS capabilities
- -60 to +250°F (-51 to +121°C)
- IEPE



### Series 3133A: Ultra Miniature Triaxial Accelerometer

Available in 4 ranges: 500g, 1,000g, 2,500g, 5,000g

- Sensitivities (mV/g): 10, 5, 2, 1
- Axis 1 & 2: 0.25 to 7,000 Hz frequency range ( $\pm 10\%$ )
- Axis 3: 0.25 to 10,000 Hz frequency range ( $\pm 10\%$ )
- 3-foot integral cable
- Adhesive mount
- 0.8 grams
- Ultra miniature design
- -60 to +250°F (-51 to +121°C)
- IEPE



### Model 3513A: Low Cost IEPE MEMS Triaxial

- 100 to 150 mV/g sensitivity;  $\pm 5g$  range
- X, Y axis: 0.2 to 1,000 Hz ( $\pm 5\%$ ) Hz
- Z axis: 0.2 to 800 Hz ( $\pm 5\%$ ) Hz
- Integral cable
- Adhesive mount
- Miniature, 2 grams
- High shock survival
- -40 to +185°F (-40 to +85°C)
- IEPE front end, MEMS sense element
- For non-recoverable or Non-Removable Transducer (NRT) locations

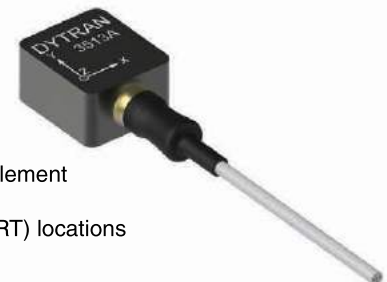



## Medium Structures/Airframes/Auto Frame/Castings



Medium-size structures need a wide range of impulse excitation due to their broadband response to high frequency and low frequency events. High sensitivity, single axis and triaxial, adhesive mounted accelerometers with excellent high and low frequency response cover the broadband response needed for test articles in this category.

### Model 3312A2T: Extended Low Frequency Accelerometer with TEDS

- 100 mV/g sensitivity, 50g range
- 0.1 to 4,000 Hz frequency range ( $\pm 5\%$ )
- 10-32 radial connector
- 10-32 tapped hole
- 25 grams
- Hermetically sealed
- -65 to +250°F (-54 to +121°C)
- IEEE 1451.4 TEDS capabilities
- Low noise



### Series 3263A: Triaxial Accelerometer

Available in 3 ranges and TEDS: 50g, 100g, 500g

- Sensitivities (mV/g): 100, 50, 10
- 0.3 to 10,000 Hz frequency range ( $\pm 15\%$ -10%)
- 4-pin 1/4-28 radial connector
- 4-40 tapped hole
- 5.6 grams
- Low noise
- Triaxial
- -60 to +250°F (-51 to +121°C)
- IEPE



### Series 7500A: High Precision MEMS Accelerometer

Available in 8 ranges: 2g, 5g, 10g, 25g, 50g, 100g, 200g, 400g

- Sensitivities (mV/g): 1,000; 400; 200; 80; 40; 20; 10; 5
- 0 to 400 Hz frequency range (3dB)
- 4-pin 1/4-28 radial connector
- Mounting via two #4 or M3 screws
- 13 grams
- Ultra low noise
- Differential output
- -67 to +257°F (-55 to +125°C)
- +9 to +32 VDC power



### Series 3097A: Miniature Accelerometer

Available in 3 ranges and TEDS: 10g, 50g, 500g

- Sensitivities (mV/g): 500, 100, 10
- 0.3 to 5,000 Hz ( $\pm 5\%$ )
- 4.3 grams
- Low noise
- Miniature cubic design allows for multi-faced mounting
- 5-40 tapped hole
- -60 to +200°F (-51 to +93°C)
- IEPE



### Series 3056D: Base Isolated

Available in 8 ranges and TEDS: 10g, 25g, 50g, 100g, 250g, 500g, 1,000g, 5,000g

- Sensitivities (mV/g): 500, 200, 100, 50, 20, 10, 5, 1
- 1 to 10,000 Hz frequency range ( $\pm 10\%$ )
- 10-32 axial connector
- 10-32 tapped hole
- 10 grams
- Hermetically sealed
- Base isolated
- -60 to +250°F (-51 to +121°C)
- IEPE



### Series 3055D: General Purpose Accelerometer

Available in 6 ranges and TEDS: 10g, 25g, 50g, 100g, 250g, 500g

- Sensitivities (mV/g): 500, 200, 100, 50, 20, 10
- 1 to 10,000 Hz frequency range ( $\pm 5\%$ )
- 10-32 radial connector
- 10-32 tapped hole
- 10 grams
- Hermetically sealed
- Base isolated
- -60 to +250°F (-51 to +121°C)
- IEPE



### Series 3255A: Non-isolated, Ultra Rugged

Available in 4 ranges: 25g, 50g, 250g, 500g

- Sensitivities (mV/g): 200, 100, 20, 10
- 10-32 radial connector
- 10-32 tapped hole
- 10 grams
- Hermetically sealed
- Low noise JFET electronics
- -60 to +250°F (-51 to +121°C)
- IEPE



### Series 3273A: Low Noise Triaxial Accelerometer

Available in 3 ranges and TEDS: 50g, 100g, 500g

- Sensitivities (mV/g): 100, 50, 10
- 4-pin 1/4-28 radial connector
- Adhesive mount
- 2.7 grams
- Extended low frequency response
- Miniature design
- Low noise JFET electronics
- -60 to +225°F (-51 to +107°C)
- IEPE

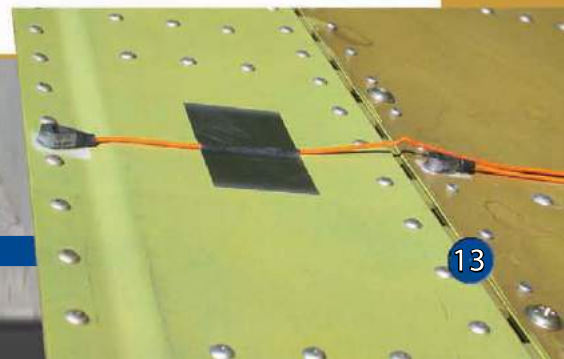



# MODAL AND STRUCTURAL ANALYSIS

## Large Structures/Seismic/Civil Engineering



Large structures vibrate at lower frequencies and lower amplitudes, and they are harder to excite with sufficient energy to support good coherence between excitation and response sensors. Dytran high sensitivity, low noise accelerometers assure high level, high quality response signals and integrity of data, even on the largest structures.

### Series 3191A: Seismic Accelerometer

Available in 2 ranges: 0.5g, 1g

- Sensitivities (mV/g): 10,000; 5,000
- 0.08 to 1,000 Hz frequency range ( $\pm 5\%$ )
- 2-pin axial connector
- 1/4-28 tapped hole
- 775 grams
- Case isolated
- Internal Faraday shield
- Available with water and oil resistant environmental boot
- -60 to +225°F (-51 to +107°C)
- High temperature version available
- IEPE



### Model 3192A: High Sensitivity Accelerometer

- 1,000 mV/g sensitivity, 5g range
- 0.5 to 1,000 Hz frequency range ( $\pm 5\%$ )
- 2-pin axial connector
- 1/4-28 tapped hole
- 190 grams
- Case isolated
- Internal Faraday shield
- Low frequency response
- -60 to +250°F (-51 to +121°C)
- IEPE



### Series 7500A: High Precision MEMS Accelerometer

Available in 8 ranges: 2g, 5g, 10g, 25g, 50g, 100g, 200g, 400g

- Sensitivities (mV/g):  
1,000; 400; 200; 80; 40; 20; 10; 5
- 0 to 400 Hz frequency range (3dB)
- 4-pin 1/4-28 radial connector
- Mounting via two #4 or M3 screws
- 13 grams
- Ultra low noise
- Differential output
- -60 to +225°F (-51 to +107°C)
- +9 to +32 VDC power



### Model 3100D24: Miniature 1v/g Accelerometer

Available with TEDS

- 1,000 mV/g sensitivity, 5g range
- 1 to 1,000 Hz frequency range ( $\pm 5\%$ )
- 10-32 radial connector
- 10-32 tapped hole
- 55 grams
- Hermetically sealed
- Case isolated
- High sensitivity
- -60 to +250°F (-51 to +121°C)
- IEPE



### Series 3233A: High Sensitivity Triaxial Accelerometer

Available in 2 ranges and TEDS: 5g; 1,000g

- Sensitivities (mV/g): 1,000; 5
- Axis 1 & 2: 0.3 to 3,000 Hz frequency range ( $\pm 10\%$ )
- Axis 3: 0.3 to 6,000 Hz frequency range ( $\pm 10\%$ )
- 4-pin 1/4-28 radial connector
- Thru hole mount
- 30 grams
- Base isolated
- 360° cable orientation
- Ultra high sensitivity
- -60 to +200°F (-51 to +93°C)
- IEPE



### Model 7503B: Triaxial Variable Capacitance Accelerometer

- 250 mV/g sensitivity
- 0 - 400 Hz frequency range (3dB)
- 9-pin, 5/16-32 UNEF-2A connector
- Stud mount
- 35 grams
- Differential mode
- Hermetically sealed
- DC response
- -40 to +250°F (-40 to +121°C)
- +3 to +11 VDC power





## Impulse Hammers

The hammers in this section are designed with interchangeable impact tips of various durometers and hardness to allow structural engineers and dynamicists to arrive at the correct combination of pulse width and frequency content of the forcing function to efficiently excite all of the modes of a test article or structure.

### Model 5800SL: Ultra Miniature Impulse Hammer

- 100 mV/LbF sensitivity
- 50 LbF range
- 75 LbF maximum force
- 10-32 connector
- 2 gram head weight
- Ultra miniature
- IEPE



### Model 5805A: 1-Pound Impulse Sledge Hammer

- 1 mV/LbF sensitivity
- 5,000 LbF range
- 10,000 LbF maximum force
- BNC connector
- 1 pound head weight
- IEPE



### Series 5800B: Dynapulse™ Impulse Hammer

Available in 4 ranges and TEDS: 50LbF; 100LbF; 500LbF; 1,000LbF

- Sensitivities (mV/LbF): 100, 50, 10, 5
- 1,000 LbF maximum force
- BNC connector
- 100 gram head weight
- IEPE



### Model 5802A: 3-Pound Impulse Sledge Hammer

Available with TEDS

- 1 mV/LbF sensitivity
- 5,000 LbF range
- 10,000 LbF maximum force
- BNC connector
- 3 pound head weight
- IEPE



### Model 5850B: Three Range Dynapulse™ Impulse Hammer

- Selectable sensitivity of 1, 10 or 100 mV/LbF
- Selectable range of 50, 500 or 5,000 LbF
- Maximum force between 1,000 and 8,000 LbF
- BNC connector
- 150 gram head weight
- IEPE



### Model 5803A: 12-Pound Impulse Sledge Hammer

Available with TEDS

- 1 mV/LbF sensitivity
- 5,000 LbF range
- 10,000 LbF maximum force
- BNC connector
- 12 pound head weight
- IEPE



## Forcing Function

### Model 1022V: IEPE Force Sensor

- 100 mV/LbF sensitivity
- 50 LbF compression range
- 50 LbF tension range
- 100 LbF maximum compression
- 75 LbF maximum tension
- 5-foot integral cable
- 10-32 tapped holes top and bottom
- 4.5 grams, miniature
- -60 to +225°F (-51 to +107°C)



### Model 5860B: Impedance Head

- 100 mV/g sensitivity
- 100 mV/LbF sensitivity
- 1 to 8,000 Hz frequency range ( $\pm 10\%$ )
- (2) 10-32 radial connectors
- 10-32 tapped hole
- 60 grams
- Simultaneously measures force & acceleration
- -100 to +250°F (-73 to +121°C)



### Series 1053V: IEPE Force Sensor

Available in 6 ranges: 1LbF; 10LbF; 50LbF; 100LbF; 500LbF; 1,000LbF

- Sensitivities (mV/LbF): 500, 100, 50, 10, 5, 1
- 10-32 radial connector
- 10-32 tapped holes top and bottom
- 28 grams
- High natural frequency
- -100 to +250°F (-73 to +121°C)



### Series 1061V: IEPE Force Sensor

Available in 7 ranges: 500LbF; 1,000LbF; 5,000LbF; 10,000LbF; 25,000LbF; 50,000LbF

- Sensitivities (mV/LbF): 10, 9, 5, 1, 0.5, 0.2, 0.1
- 10-32 radial connector
- 3/8-16 tapped hole top and bottom
- 452 grams
- Wide frequency range
- -100 to +250°F (-73 to +121°C)

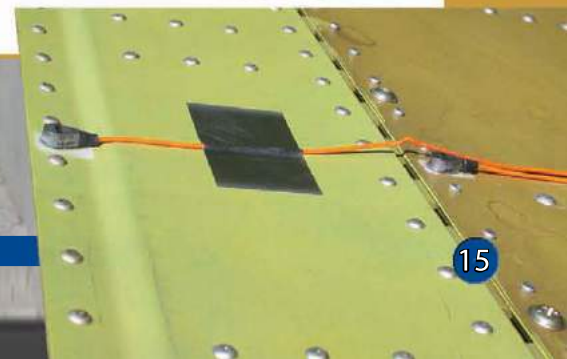



# HUMS AND CONDITION BASED MAINTENANCE (CBM)

Health and Usage Monitoring Systems (HUMS) used for Condition Based Maintenance (CBM) programs and/or Vibration Health Monitoring (VHM) systems rely on accelerometers that have been specifically developed to meet the challenges of tough airborne environments. Dytran accelerometers have been deployed on military and civilian rotorcraft since the late 1980's and are field-proven to meet CAP-753 requirements for measurement and recording of VHM indicators. We work with all manufacturers of HUMS and VHM systems by providing sensors that enable CBM programs to realize the primary goals of improving operational safety, maintenance cost savings, and increased availability of aircraft.

## Rotor Track and Balance

Accelerometers in this category are for blade track and balance, rotor smoothing, airframe vibration feedback, and swashplate bearing wear indicators. This group is characterized by excellent low frequency and phase response, high sensitivities, and a variety of connector/mounting configurations.

### Series 3062A: Bayonet Connector

Available in 2 ranges: 200g, 500g

- Sensitivities (mV/g): 25, 10
- 0.48 to 10,000 Hz frequency range ( $\pm 5\%$ )
- 1/4-28 stud mount
- 40 grams
- Hermetically sealed
- Case isolated
- Spark-plug shaped accelerometer package
- -60 to +305°F (-51 to +151°C)
- IEPE



### Model 3237A: D38999 Connector

- 25 mV/g sensitivity, 200g range
- 0.48 to 10,000 Hz frequency range ( $\pm 5\%$ )
- 1/4-28 stud mount
- 37 grams
- Spark-plug shaped accelerometer package
- -60 to +305°F (-51 to +151°C)
- IEPE



## Hanger Bearing, Tail Rotor, Driveshafts

Products in this category measure imbalance, misalignment, and bearing wear in drive shafts and slower-rotating components. This group features the Dytran-innovated "Bracket-Style" mounting configuration that allows installation under the head of a bolt, eliminating the need for a separate mounting bracket. Measurement axis direction varies according to intended mounting location, allowing orientation of the accelerometer to the axis of greatest motion. Integral cable versions are available in customer selected lengths, check factory for details.

### Model 3077A: Single Axis

- 10 mV/g sensitivity, 500g range
- 1.1 to 5,000 Hz frequency range ( $\pm 10\%$ )
- $\varnothing.31$  thru hole mount
- -60 to +250°F (-51 to +121°C)
- 11 grams

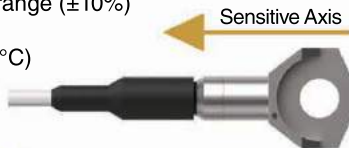

### Model 3078A: Single Axis

- 10 mV/g sensitivity, 500g range
- 0.7 to 5,000 Hz frequency range ( $\pm 10\%$ )
- $\varnothing.31$  thru hole mount
- -60 to +250°F (-51 to +121°C)
- 20 grams



### Model 3079A: Single Axis

- 10 mV/g sensitivity, 500g range
- 1.1 to 5,000 Hz frequency range ( $\pm 10\%$ )
- $\varnothing.26$  thru hole mount
- -60 to +250°F (-51 to +121°C)
- 11 grams



### Model 3091A: Single Axis

- 10 mV/g sensitivity, 500g range
- 10 to 1,000 Hz frequency range ( $\pm 5\%$ )
- 3-pin "Mighty Mouse™" radial connector
- $\varnothing.31$  thru hole mount
- -60 to +250°F (-51 to +121°C)
- 25 grams



### Model 3302A: Biaxial

- 10 mV/g sensitivity, 500g range
- 10 to 1,000 Hz frequency range ( $\pm 5\%$ )
- 3-pin "Mighty Mouse™" radial connector
- $\varnothing.31$  thru hole mount
- -60 to +250°F (-51 to +121°C)
- 30 grams



### Series 3232A: Biaxial

Available in 2 ranges: 50g, 500g

- Sensitivities (mV/g): 100, 10
- 3.3 to 2,500 Hz frequency range ( $\pm 10\%$ )
- 3-pin "Mighty Mouse™" radial connector
- $\varnothing.27$  thru hole mount
- -60 to +250°F (-51 to +121°C)
- 45 grams

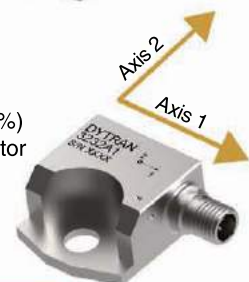



## Transmission, Gearbox, Bearings



This group addresses main gearbox, accessory gearbox, intermediate and tail rotor gearbox. Select sensors from this group for shaft order 1 (SO1), shaft order 2 (SO2), gear mesh frequency, gear tooth indicators, and bearing wear indicators. This group is characterized by excellent high frequency response to 20 kHz and ring-style mounting to accommodate cable & connector orientation.

### Model 3236A: Airborne Accelerometer

- 10 mV/g sensitivity, 500g range
- 1.2 to 10,000 Hz frequency range ( $\pm 5\%$ )
- 3-pin "Mighty Mouse™" radial connector
- $\varnothing 1.7$  thru hole mount
- 28.1 grams
- 360° cable orientation
- -60 to +300°F (-51 to +149°C) operation
- IEPE



### Series 3168: Airborne Accelerometer

- 10 mV/g sensitivity, 500g range
- 1 to 20,000 Hz frequency range ( $\pm 5\%$ )
- 8-32 thru hole mount (other options available)
- 23 grams
- 360° cable orientation
- High frequency response
- IEPE
- Also available in 25 mV/g
- -60 to +250°F (-51 to +121°C)
- Cable length is customer-selectable



## Engine



Designed for power turbine and gas generator "hot section" locations to measure vibration spectrum during run-up and SO1, SO2 at the shaft origin between engine and transmission. The products are configured using charge-mode (non-amplified) high temperature accelerometers, an in-line charge amplifier, and interconnecting cables. The combined system operates from IEPE power, or from 28 VDC aircraft power.

### System 5334: IEPE Accelerometer

- 10 mV/g sensitivity, 500g range
- 4.8 to 660 frequency range ( $\pm 5\%$ )
- 18-inch integral hardline cable assembly
- Tri-bolt mount
- 150 grams
- Uniquely combines IEPE and charge output technology, seamlessly operating as a single unit
- -65 to +900°F (-53 to +482°C) (accel)
- -50 to +185°F (-45 to +85°C) (charge amp)
- IEPE



### Model 3218C: Charge Mode High Temperature Accelerometer

- 1.6 pC/g sensitivity
- 10,000 Hz upper frequency range ( $\pm 10\%$ )
- Integral 2-foot hardline cable assembly to D38999 output connector
- Tri-bolt mount
- 157 grams
- -65 to +900°F (-51 to +482°C)
- Charge mode



## Custom High Temperature Configurations/Engine Harnesses



Let Dytran configure a custom sensor/cable/in-line charge amplifier solution for your high temperature engine monitoring needs. Engine monitoring sensors are nearly always tailored to meet specific requirements for each individual engine manufacturer and Dytran is well-versed at designing high temperature systems to integrate smoothly with any HUMS/CBM architecture. The products in this section are intended to show some of the possibilities; call or email us today to find out more!

### Single Axis with In-Line Charge Amp



### IEPE "3-in-1" High Temp Accelerometer Harness





# FLIGHT TEST

Dytran sensors have been used by flight test engineers in fixed-wing aircraft, rotorcraft, launch vehicle, and spacecraft flight test programs since the mid-1980's. Sensors in this category incorporate IEPE and charge mode piezoelectric technology, as well as variable capacitance DC-MEMS technology. Rugged, hermetically sealed packages designed to withstand the rigors of the flight test environment are time-tested and field proven to enable smooth completion of flight test data requirements, on schedule and on budget.

## IEPE Single Axis

Examine flutter, buzz, stores separation, gunfire effects on systems, vibro-acoustics effects on cockpits and crews, landing acceleration loads, and actuator-induced vibrations. For use in verifying and updating the aircraft analytical model when changes are made to aircraft structures or when new stores are added.

### Model 3220M27: Miniature Accelerometer

- 1 mV/g sensitivity, 5,000g range
- 0.6 to 10,000 Hz ( $\pm 5\%$ )
- 5-44 radial connector
- $\varnothing$ .09-inch (2.36-millimeter) thru hole mount
- 2.7 grams
- 360° cable orientation
- -60 to +250°F (-51 to +121°C)



### Series 7705A: Extended Low Frequency (ELF™) Accelerometer

- Available in 3 ranges: 20g, 40g, 200g
- Sensitivities (mV/g): 10, 50, 100
  - 0 to 10,000 Hz frequency range ( $\pm 10\%$ )
  - 15 grams
  - Hybrid design, dual mode technology: incorporates AC and DC sensing elements into one sensor
  - -60 to +250°F (-51 to +121°C)
  - 5-28 VDC power



### Series 3274A: Miniature Accelerometer with TEDS

- Available in 3 ranges: 200g; 500g; 1,000g
- Sensitivities (mV/g): 25, 10, 5
  - 1.1 to 10,000 Hz ( $\pm 10\%$ )
  - 3-foot (0.9-meter) removable cable
  - Adhesive mount
  - 2 grams, ultra miniature teardrop design
  - Case isolated
  - IEEE 1451.4 TEDS capabilities
  - -60 to +250°F (-51 to +121°C)



### Model 3315A: Low Noise

- 20 mV/g sensitivity, 250g range
- 0.5 to 10,000 Hz frequency range ( $\pm 3\text{dB}$ )
- 1/4-28 tapped hole
- 49 grams
- Low noise JFET electronics
- Low profile design
- -60 to +250°F (-51 to +121°C)



## IEPE Triaxial

Analyze three-axis vibration and modal effects in structures, and structure-borne noise/vibration from APUs, engines, and flutter effects on fuselages and control surfaces. Verify GVT mode shapes, frequencies, damping, and amplitudes.

### Model 3093M16: Triaxial Accelerometer

- 50 mV/g sensitivity, 100 Gpeak
- Adhesive mount
- 13 grams
- Hermetically sealed, case isolated
- -60 to +256°F (-51 to +124°C)



### Model 3093M10: Triaxial Accelerometer

- 50 mV/g sensitivity, 100 Gpeak
- 2 to 5,000 Hz frequency range ( $\pm 5\%$ )
- 10 grams
- Hermetically sealed, case isolated
- TEDS function
- -60 to +250°F (-51 to +121°C)



### Model 3513A: Low Cost Triaxial

- 100 to 150 mV/g sensitivity;  $\pm 5\text{g}$  range
- X, Y axis: 0.2 to 1,000 Hz frequency range ( $\pm 5\%$ )
- Z axis: 0.2 to 800 Hz frequency range ( $\pm 5\%$ )
- Integral cable, adhesive mount
- 2 grams, aluminum housing
- High shock survival
- Low profile
- -40 to +185°F (-40 to +85°C)
- For non-recoverable or Non-Removable Transducer (NRT) locations



### Model 3273A2: Triaxial Accelerometer

- 100 mV/g sensitivity, 50g range
- 0.7 to 3,000 Hz frequency range ( $\pm 5\%$ )
- 2.7 grams
- Extended low frequency response
- Miniature design
- Low noise JFET electronics
- -60 to +225°F (-51 to +107°C)



### Model 3193B: Low Profile Triaxial Accelerometer

- 10 mV/g sensitivity, 500g range
- 2 to 5,000 Hz ( $\pm 5\%$ )
- Permanently attached 18 in hook up cable with shrink tubing, 4-wire, 25 GA
- 75 grams
- Flat surface or adhesive mount
- -65 to +250°F (-53 to +121°C)
- IEPE





## DC MEMS Single Axis & Triaxial

Low frequency structural mode identification, aeroelastic vibration mode studies, load factors during pitch, roll, yaw maneuvers, rudder displacement, landing gear and flap deployment accelerations. DC sensors provide excellent phase relationship between sensors when multiple points are examined.

### Series 7500A: High Precision MEMS Accelerometer

Available in 8 ranges: 2g, 5g, 10g, 25g, 50g, 100g, 200g, 400g

- Sensitivities (mV/g): 1,000; 400; 200; 80; 40; 20; 10
- 0 to 400 Hz frequency range (3dB)
- 13 grams
- Ultra low noise
- Hermetically sealed
- Differential mode
- -67 to +257°F (-55 to +125°C)
- +9 to +26 VDC power



### Series 7600B: High Precision MEMS Accelerometer

Available in 6 ranges: 5g, 10g, 25g, 50g, 100g, 200g

- Sensitivities (mV/g): 100, 50, 20, 10, 5, 2.5
- 0 to 600 Hz frequency range (3dB)
- 3.6 grams, MEMS technology
- Hermetically sealed
- Differential mode
- -40 to +248°F (-40 to +120°C)
- +9 to +26 VDC power
- VC technology powered by strain gage amplifiers



### Series 7503A: High Precision Triaxial MEMS Accelerometer

Available in 7 ranges: 2g, 5g, 10g, 25g, 50g, 100g, 200g

- Sensitivities (mV/g): 1,000; 400; 200; 80; 40; 20; 10
- 0 to 400 Hz frequency range (3dB)
- 13 grams
- Ultra low noise
- Hermetically sealed
- Differential mode
- -40 to +250°F (-40 to +121°C)
- +9 to +26 VDC power



### Series 7603B: High Precision Triaxial MEMS Accelerometer

Available in 8 ranges: 2g, 5g, 10g, 25g, 50g, 100g, 200g, 400g

- Sensitivities (mV/g): 250, 100, 50, 25, 10, 5, 2.5, 1.25
- 0 to 400 Hz frequency range (3dB)
- 35 grams, ultra low noise
- Hermetically sealed
- Differential mode
- -40 to +250°F (-40 to +121°C)
- +9 to +26 VDC power
- VC technology powered by strain gage amplifiers



## High Temperature Locations

Install near engines, APU's and other high temperature locations exceeding the high limit of typical IEPE sensors.

### Model 3400C: Charge Mode Accelerometer

- 3 pC/g sensitivity; 1,700g range
- 20,000 Hz upper frequency range ( $\pm 1$ dB)
- 10-32 mounting screw
- Light weight, 3.05 grams
- High frequency
- -67 to +500°F (-55 to +260°C)
- Anti-resonance domed cap



### Model 3093M27: High Temperature Triaxial Accelerometer

- 10 mV/g sensitivity, 500g range
- 3.3 to 3,000 Hz frequency range ( $\pm 5\%$ )
- 4-pin 1/4-28 radial connector
- 10-32 tapped hole
- 15 grams
- Case isolated
- Low profile
- -60 to +320°F (-51 to +160°C)
- IEPE



## Charge Amplifiers/Signal Conditioning

In-line charge amplifiers for non-amplified PE sensors are a convenient, cost-effective way to condition sensors in high temperature mounting locations. These rugged charge amplifiers operate from IEPE power and can drive long cables without impedance matching problems. Dytran also offers custom IEPE power units that operate from +28 VDC aircraft power and condition up to six IEPE sensor channels.

### In-Line Charge Amplifiers



### 4139: Airborne IEPE Power Unit

- 6 channel
- Operates from +28 VDC aircraft power
- 10-32 jack input connectors
- DA-15P output connector





# MEMS-DC RESPONSE ACCELEROMETERS

DC response MEMS accelerometers are used for low frequency dynamic and steady-state linear acceleration events, flight tests, transportation environment replication/simulation, modal and structural analysis, ride quality, road load, tilt and inclination measurements, among many others. Dytran offers a wide range of configurations, including single axis and triaxial designs, and our new, innovative USB-powered three-axis VibraScout™ 3D and the six degrees of freedom VibraScout™ 6D series.

## USB Powered

Dytran VibraScout™ accelerometers plug directly into your laptop or PC for instant acquisition of triaxial or 6DoF data; no external power supply or signal conditioning needed. It's the easiest, most convenient way to complete 3-axis and 6-axis vibration studies and to produce data for reports, all with your own computer! Go to our website for complete details and computer system requirements.

### System 5340: VibraScout™ Triaxial Vibration Sensor and Analysis Software

*The Dytran 7543B USB Digital Tri-axial Accelerometer combines a 3-Axis MEMS accelerometer with a microcontroller to create an intelligent sensor.*

#### Features:

- 16g range
- 4-pin 1/4-28 radial connector
- 17 grams
- Embedded microcontroller
- -40 to +185°F (-40 to +85°C)
- 3.8 to 6.0 VDC power



System Package

### System 5346A: VibraScout 6D™ USB Powered Triaxial Vibration Sensor and Analysis Software

*The VibraScout 6D™ is a USB compatible, "plug and play" portable, very affordable six degrees of freedom data acquisition system. Measure X,Y,Z acceleration, Roll, Pitch, Yaw and Temperature using a laptop or tablet with a USB port.*

#### Features:

- 14g range
- 4-pin 1/4-28 radial connector
- 13 grams
- Three-directional vibration data acquisition (accelerometer) and three-directional orientation data acquisition (gyroscope)
- -40 to +185°F (-40 to +85°C)
- 3.8 to 6.0 VDC power



## Economical / Cost Effective

Ultra-high precision DC-MEMS sensors can be expensive, so Dytran has introduced a line of lower-specification, lower cost DC sensors to address applications where extra precision is not needed.

### Series 7504A: DC Response Accelerometer

Available in 8 ranges: 2g, 5g, 10g, 25g, 50g, 100g, 200g, 400g

- Sensitivities (mV/g): 2,000; 800; 400; 160; 80; 40; 20; 10
- 0 to 400 Hz frequency range (3dB)
- 5-foot integral cable
- Mounting via two 8-32 screws
- 20 grams
- Differential output
- -67 to +257°F (-55 to +125°C)
- +5 VDC power



### Series 7531A: DC Response Accelerometer

Available in 4 ranges: 3g, 5g, 16g, 200g

- Sensitivities (mV/g): 300, 174, 57, 6.5
- 0 to 550 Hz frequency range (3dB)
- 6 conductor cable
- Mounting via two M2 screws
- 6 grams
- 1.3 to 1.7 VDC power
- -40 to +185°F (-40 to +85°C)
- Wide supply voltage range, low current consumption



### Series 7533A: Triaxial DC Response Accelerometer

Available in 4 ranges: 3g, 5g, 16g, 200g

- Sensitivities (mV/g): 300, 174, 57, 6.5
- Axis X&Y: 0 to 1,600 Hz frequency range (3dB)
- Axis Z: 0 to 550 Hz frequency range (3dB)
- 6 conductor cable, mounting via two M2 screws
- 6 grams
- 4 to 28 VDC power, X,Y axes: 1.3 to 1.7; Z axis: 1.2 to 1.8
- -40 to +185°F (-40 to +85°C)
- Wide supply voltage range, low current consumption





## Single Axis High Performance

### Series 7602B: High Precision MEMS Accelerometer

Available in 6 ranges: 5g, 10g, 25g, 50g, 100g, 200g

- Sensitivities (mV/g): 100, 50, 20, 10, 5, 2.5
- 0 to 600 Hz frequency range (3dB)
- 4-pin M4.5 x 0.35 radial connector
- Mounting via two 4-40 screws
- 3.6 grams
- Differential output
- -40 to +176°F (-40 to +80°C)
- +5 VDC power



### Series 7600B: High Precision MEMS Accelerometer

Available in 6 ranges: 5g, 10g, 25g, 50g, 100g, 200g

- Sensitivities (mV/g): 100, 50, 20, 10, 5, 2.5
- 0 to 600 Hz frequency range (3dB)
- 4-pin M4.5 x 0.35 radial connector
- Mounting via two 4-40 screws
- 3.6 grams
- Differential output
- -40 to +248°F (-40 to +120°C)
- +5 VDC power



### Series 7700A: High Precision MEMS Accelerometer

Available in 6 ranges: 5g, 10g, 25g, 50g, 100g, 200g

- Sensitivities (mV/g): 100, 50, 20, 10, 5, 2.5
- 0 to 600 Hz frequency range (3dB)
- 4-pin M4.5 x 0.35 radial connector
- 10-32 tapped hole
- 8 grams
- Differential output
- -40 to +176°F (-40 to +80°C)
- Same power supply requirements as strain gage sensors



### Series 7500A: High Precision MEMS Accelerometer

Available in 8 ranges: 2g, 5g, 10g, 25g, 50g, 100g, 200g, 400g

- Sensitivities (mV/g): 1,000; 400; 200; 80; 40; 20; 10; 5
- 0 to 400 Hz frequency range (3dB)
- 4-pin 1/4-28 radial connector
- Mounting via two #4 or M3 screws
- 13 grams
- Ultra low noise
- Differential output
- -67 to +257°F (-55 to +125°C)
- +9 to +32 VDC power



### Series 7701A: High Precision MEMS Accelerometer

Available in 6 ranges: 2g, 5g, 10g, 25g, 50g, 100g, 200g

- Sensitivities (mV/g): 100, 50, 20, 10, 5, 2.5
- 0 to 600 Hz frequency range (3dB)
- 5-pin M5-5 radial connector
- 10-32 tapped hole
- 8 grams
- Differential output
- -40 to +176°F (-40 to +80°C)
- Same power supply requirements as strain gage sensors



### Series 7705A : Extended Low Frequency Response Accelerometer (ELF™)

Available in 3 ranges: 20g, 40g, 200g

- Sensitivities (mV/g): 100, 50, 10
- 0 to 10,000 Hz frequency range ( $\pm 10\%$ )
- 4-pin M4.5 x 0.35 radial connector
- 10-32 tapped hole
- 15 grams
- -60 to +250°F (-51 to +121°C)
- Hybrid design
- Dual mode technology: incorporates AC and DC into one sensor



## Triaxial High Performance

### Series 7603B: High Precision Triaxial MEMS Accelerometer

Available in 8 ranges: 2g, 5g, 10g, 25g, 50g, 100g, 200g, 400g

- Sensitivities (mV/g): 250, 100, 50, 20, 10, 5, 2.5, 1.25
- 0 to 400 Hz frequency range (3dB)
- 9-pin 5/16-32 radial connector
- 1/4-28 tapped hole
- 35 grams
- Ultra low noise
- Differential output
- -40 to +250°F (-40 to +121°C)
- Same power supply requirements as strain gage sensors



### Series 7503D: High Precision Triaxial MEMS Accelerometer

Available in 10 ranges:

2g, 5g, 10g, 25g, 50g, 100g, 200g, 400g, 800g, 1600g

- Sensitivities (mV/g): 2,000; 800, 400, 160, 80, 40, 20, 10, D9: 800(X&Y), 160(Z), D10: 800(X&Y), 80(Z)
- 0 to 400 Hz frequency range (3dB)
- 9-pin 5/16-32 radial connector
- Mounting via two 8-32 or M4 screws, 38 grams
- Ultra low noise ( $\mu\text{g}/\sqrt{\text{Hz}}$ ): 5 to 400
- Differential output
- -40 to +250°F (-40 to +121°C)
- +9 to +36 VDC power





# TURBINE ENGINE, TEST CELL & HIGH TEMPERATURE

High temperature piezoelectric vibration sensors are essential to the design/development cycle of gas turbine engines, gearboxes, APU's and other components that are required to operate safely and efficiently in temperatures up to 900 degrees F in an engine test cell environment. The products in this section are also used to continually monitor the performance of engines in the field for HUMS and other machinery Condition Based Maintenance (CBM) programs and many of them are easily customizable with user-specified features such as mounting configuration, sensitivity, temperature range, and cable length.

## Turbine, Engine Test Stand Vibration and Flight Test

### Model 3088C: High Temperature Accelerometer

- 10 pC/g sensitivity
- 5,000 Hz upper frequency range ( $\pm 5\%$ )
- 10-32 radial connector
- 10-32 tapped hole
- 42 grams
- -60 to +600°F (-51 to +315°C)
- Small size
- Charge mode
- Use with 4751B & 4754B series in-line charge amps



### Model 3092C: High Temperature Accelerometer

- 3.5 pC/g sensitivity
- 5,000 Hz upper frequency range ( $\pm 10\%$ )
- 10-32 radial connector
- 10-32 tapped hole
- 42 grams
- -60 to +900°F (-51 to +482°C)
- Small size
- Charge mode
- Use with 4751B & 4753B series in-line charge amps



### Series 3316M3: High Temperature Accelerometer

- 1 to 2 pC/g sensitivity
- 10,000 Hz upper frequency range ( $\pm 10\%$ )
- 10-32 radial connector
- 10-32 tapped hole
- 6 grams, miniature cubic design
- Inconel™
- High frequency response
- -60 to +1,000°F (-51 to +538°C)
- Charge mode
- Patented Silver Window™ Technology



### Model 6998: High Temperature Isolated Mounting Base

- High temperature operation
- Hex Size: 0.50 inches
- Thickness: 0.39 inches
- Mounting: 10-32 tapped hole top and bottom
- Material: stainless steel



## High Temperature / Turbine Engine

### Model 3196C: High Temperature Accelerometer

- 8 pC/g sensitivity
- 2,500 Hz upper frequency range ( $\pm 5\%$ )
- Tri-bolt mount
- Use with 6425AXX cable
- 85 grams
- -65 to +500°F (-53 to +260°C)
- Charge mode
- Use with 4705M8 in-line charge amp



### Model 3085C: High Temperature Accelerometer

- 10 pC/g sensitivity
- 2,500 Hz upper frequency range ( $\pm 5\%$ )
- Tri-bolt mount
- 75 grams
- -65 to +600°F (-53 to +315°C)
- Differential output
- Charge mode
- Use with 4707 series in-line charge amp



### Model 3197C: High Temperature Accelerometer

- 2.4 to 4.5 pC/g sensitivity
- 2,500 Hz upper frequency range ( $\pm 5\%$ )
- Tri-bolt mount
- Use with 6425AXX cable
- 85 grams
- Stainless steel
- -65 to +500°F (-53 to +260°C)
- Charge mode
- Use with 4705M8 in-line charge amp



### Series 3235C: High Temperature Accelerometer

Available in 3 sensitivities: 50 pC/g, 100pC/g, 200pC/g

- 10,000 Hz upper frequency range ( $\pm 15\%$ )
- 2-pin radial connector
- Tri-bolt mount
- 69 grams
- Differential output
- High sensitivity
- -60 to +550°F (-51 to +287°C)
- Charge mode
- Use with 4707 series in-line charge amp





## Engine

Designed for power turbine and gas generator "hot section" locations to measure vibration spectrum during run-up and SO1, SO2 at the shaft origin between engine and transmission. The products are configured using charge-mode (non-amplified) high temperature accelerometers, an in-line charge amplifier, and interconnecting cables. The combined system operates from IEPE power, or from 28 VDC aircraft power.

### System 5334: IEPE High Temperature Accelerometer

- 10 mV/g sensitivity, 500g range
- 4.8 to 660 frequency range ( $\pm 5\%$ )
- 18-inch integral hardline cable assembly
- Tri-bolt mount
- 150 grams
- Uniquely combines IEPE and charge output technology, seamlessly operating as a single unit
- -65 to +900°F (-53 to +482°C)
- IEPE



### Model 3218C: Charge Mode High Temperature Accelerometer

- 1.6 pC/g sensitivity
- 10,000 Hz upper frequency range ( $\pm 10\%$ )
- Integral 2-foot hardline cable assembly to D38999 output connector
- Tri-bolt mount
- 157 grams
- -65 to +900°F (-53 to +482°C)
- Charge mode



## Custom High Temperature Configurations/Engine Harnesses

Let Dytran configure a custom sensor/cable/in-line charge amplifier solution for your high temperature engine monitoring needs. Engine monitoring sensors are nearly always tailored to meet specific requirements for each individual engine manufacturer and Dytran is well-versed at designing high temperature systems to integrate smoothly with any HUMS/CBM architecture. The products in this section are intended to show some of the possibilities; call or email us today to find out more!

### Single Axis with In-Line Charge Amp



### IEPE "3-in-1" High Temp Accelerometer Harness



## Charge Amplifiers

### Series 4705A: In-Line Charge Amplifier

Available in 4 ranges: 100 pC; 500 pC; 5,000 pC; 50,000 pC

- Sensitivities (mV/pC): 50, 10, 1, 0.1
- BNC jack to BNC jack
- 33 grams
- Operates with sensors with a minimum insulation resistance of 1 G $\Omega$  (A1); 200 M $\Omega$  (A2); 2 M $\Omega$  (A3); 1 M $\Omega$  (A4)
- -50 to +185°F (-45 to +85°C)



### Series 4707M: In-Line Charge Amplifier

- Sensitivities (mV/pC): 30, 5, 1, 0.05
- 1D38999/25A35PEN to D38999/26WA35SN connection
- 54 grams
- Operates with sensors with a minimum insulation resistance of 10 M $\Omega$
- 32 to +158°F (0 to +70°C)



### Series 4711A: In-Line Charge Amplifier

Available in 3 ranges: 500 pC; 5,000 pC; 50,000 pC

- Sensitivities (mV/pC): 10, 1, 0.1
- 10-32 jack to BNC plug
- 33 grams
- Operates with sensors with a minimum insulation resistance of 1 M $\Omega$
- -50 to +185°F (-45 to +85°C)



### Series 4753B: In-Line Charge Amplifier

Available in 2 ranges: 500 pC; 5,000 pC

- Sensitivities (mV/pC): 10, 1
- 10-32 jack to BNC jack
- 25 grams
- Operates with sensors with a minimum insulation resistance of 10 k $\Omega$
- -40 to +185°F (-40 to +85°C)



### Series 4751B: In-Line Charge Amplifier

Available in 4 ranges: and TEDS 100 pC; 500 pC; 5,000 pC; 50,000 pC

- Sensitivities (mV/pC): 50, 10, 1, 0.1
- 10-32 jack to 10-32 jack
- 25 grams
- Operates with sensors with a minimum insulation resistance of 10 M $\Omega$
- -50 to +188°F (-45 to +86°C)



### Model 4754B: In-Line Charge Amplifier

- 10 mV/pC sensitivity, 500 pC range
- 10-32 jack to 10-32 jack
- 17 grams
- Operates with sensors with a minimum insulation resistance of 10 k $\Omega$
- -40 to +185°F (-40 to +85°C)

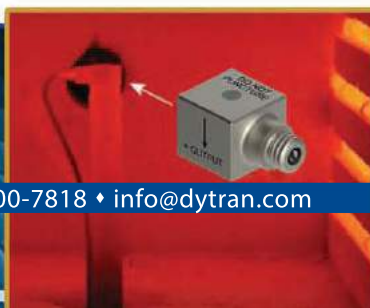



# SPACE VEHICLE, GROUND & FLIGHT TESTING

Rocket boosters and spacecraft are subject to high levels of vibration affecting structures and on-board equipment. Dytran AC and DC response accelerometers monitor structural interactions with propulsion systems and flight control systems that can cause low frequency flight instabilities. Space flight sensors are low-outgassing, lightweight, and are packaged in hermetically sealed housings to withstand extreme environments.

## Satellite Rocket & Capsule GVT and Modal Testing

Measure and evaluate all aspects of structural dynamics and component response including vibration, modal analysis, and shock in both large and small space structures. For use in characterizing flight and non-flight hardware in ground test vibration laboratories.

### Series 3224A: Miniature Accelerometer

Available in 4 ranges: 500g; 1,000g; 2,500g, 5,000g

- Sensitivities (mV/g): 10, 5, 2, 1
- 0.3 to 20,000 Hz ( $\pm 5\%$ )
- 3-foot (0.9-meter) integral cable
- Adhesive mount
- 0.2 grams, titanium housing
- -60 to +300°F (-51 to +149°C)
- Ultra miniature teardrop design
- IEPE



### Series 3133A: Triaxial Accelerometer

Available in 4 ranges: 500g, 1,000g, 2,500g, 5,000g

- Sensitivities (mV/g): 10, 5, 2, 1
- Axis 1 & 2: 0.25 to 7,000 Hz frequency range ( $\pm 10\%$ )
- Axis 3: 0.25 to 10,000 Hz frequency range ( $\pm 10\%$ )
- 3-foot integral cable, adhesive mount
- 0.8 grams, ultra miniature design
- -320 to +250°F (-196 to +121°C)
- IEPE
- TEDS version available: 3133DT



### Series 3274A: Miniature Accelerometer with TEDS

Available in 3 ranges: 200g; 500g; 1,000g

- Sensitivities (mV/g): 25, 10, 5
- 1 to 10,000 Hz ( $\pm 10\%$ )
- 3-foot (0.9-meter) removable cable
- Adhesive mount, case isolated
- 2 grams, ultra miniature design
- IEEE 1451.4 TEDS capabilities
- -60 to +250°F (-51 to +121°C)
- IEPE
- Isolated teardrop style



### Model 3225M40: High Temperature Accelerometer

- 1.8 pC/g sensitivity
- 10,000 Hz upper frequency range ( $\pm 10\%$ )
- Integral 3-foot cable assembly
- Adhesive mount
- 0.6 grams
- Ultra miniature teardrop design
- -60 to +350°F (-51 to +171°C)
- Low outgassing
- Charge mode



### Series 3273A: Triaxial Accelerometer

Available in 2 ranges and TEDS: 50g, 500g

- 10 mV/g sensitivity, 500g range
- 0.5 to 3,000 Hz frequency range ( $\pm 5\%$ )
- 4-pin 1/4-28 radial connector
- Adhesive mount
- 2.7 grams, miniature design
- Extended low frequency response
- Low noise JFET electronics
- -60 to +225°F (-51 to +107°C)
- IEPE



### Series 3143D: Triaxial Accelerometer

Available in 3 ranges: 50g, 100g, 500g

- Sensitivities (mV/g): 100, 50, 10
- 0.5 to 3,000 Hz frequency range ( $\pm 5\%$ )
- 4-pin 1/4-28 radial connector
- Thru hole mount
- 14 grams, case isolated
- 360° cable orientation
- Low profile
- -60 to +185°F (-51 to +85°C)
- IEPE



## High Shock Testing

For explosive bolt, stage separation, drop testing, shipboard shock testing, pendulous mass tests.

### Series 3200B: Shock Accelerometer

6 ranges: 2,500g; 5,000g; 10,000g; 20,000g; 50,000g; 70,000g

- Sensitivities (mV/g): 2, 1, 0.5, 0.25, 0.1, 0.05
- 0.35 to 10,000 Hz frequency range ( $\pm 10\%$ )
- 10-32 axial connector, 1/4-28 mounting stud
- 6 grams, lightweight, base isolated
- High natural frequency of >90 kHz
- -60 to +250°F (-51 to +121°C)
- IEPE
- TEDS versions available



### Series 3086A: Shock Accelerometer

6 ranges: 2,500g; 5,000g; 10,000g; 20,000g; 50,000g; 70,000g

- Sensitivities (mV/g): 2, 1, 0.5, 0.25, 0.1, 0.05
- 0.35 to 10,000 Hz frequency range ( $\pm 10\%$ )
- Axial mounted solder pins
- 1/4-28 stud mount
- 3.5 grams, lightweight
- Base isolated
- High natural frequency of 100 kHz
- -60 to +250°F (-51 to +121°C)
- IEPE
- TEDS versions available





## Structural Flight Test & Engine Test Stand

Dytran AC and DC response space flight sensors are used to acquire modal analysis, damping, resonant frequency, and load data during flight. Vibration in cold flows sections are addressed with IEPE cryogenic accelerometers and DC-MEMS sensor are for modal and load analysis.

### Model 3143M16: Cryogenic Triaxial Accelerometer

- 10 mV/g sensitivity, 500g range
- 1.6 to 5,000 Hz frequency range ( $\pm 5\%$ )
- 4-pin 3/8-28 Glenair™ radial connector
- 6-32 thru hole mount
- 50 grams
- Case isolated
- -320 to +250°F (-196 to +121°C)
- IEPE
- For O2 tanks, pumps and other cold section hardware



### Model 3143M12: IEPE Triaxial Accelerometer

- 10 mV/g sensitivity
- 0.5 to 10,000 Hz frequency range ( $\pm 5\%$ )
- Mounting scrow model 6247
- 47 grams
- Excellent linearity
- -60 to +185°F (-51 to +85°C)
- +11 to +13 VDC power
- Modal analysis
- Natural frequencies damping



### Model 7500M11: High Precision MEMS Accelerometer

- 5 mV/g sensitivity
- 400g range; 50g range version: 7500M10
- 0 to 300 Hz frequency range (3dB)
- 4-pin "Mighty Mouse™" radial connector
- Mounting via two 4-40 screws
- 45 grams
- Ultra low noise, differential output
- -67 to +257°F (-55 to +125°C)
- +9 to +32 VDC power
- DC response
- For modal, low frequency & load analysis



### Model 3306A1: Cryogenic Accelerometer

- 5 mV/g sensitivity; 1,000g range
- 4.8 to 1,800 Hz frequency range ( $\pm 5\%$ )
- 3-pin military Bayonet-style axial connector
- 1/4-28 stud mount
- 37 grams
- Case isolated
- -320 to +300°F (-195 to +149°C)
- Two-pole low pass filter
- Stable Mosfet amplifier technology
- IEPE



## Hot Firing/Engine Test Stand Vibration

Measure vibration on or near engines, nozzles, pumps, impellers, high frequency bearings, shafts and electronics enclosures mounted in high temperature areas during hot firings.

### Model 3309A: High Temperature Accelerometer

- 5 pC/g sensitivity
- 5,000 Hz upper frequency range ( $\pm 5\%$ )
- 3-pin "Mighty Mouse™" radial connector
- $\varnothing$ .17 thru hole mount
- 25.5 grams
- Case isolated
- 360° cable orientation
- -60 to +482°F (-55 to +250°C)
- Charge mode



### Series 3316C: High Temperature 900°F

Available in 2 ranges: 500g, 3,000g

- 1 to 2 pC/g sensitivity
- 10,000 Hz upper frequency range ( $\pm 10\%$ )
- 10-32 radial connector
- 5-40 tapped hole
- 6 grams, Inconel™ housing
- Miniature cubic design
- High frequency response
- -60 to +900°F (-51 to +482°C)
- Charge mode
- Patented Silver Window™ Technology



### Model 3092C: 900°F Accelerometer

- 3.5 pC/g sensitivity
- 5,000 Hz upper frequency range ( $\pm 10\%$ )
- 10-32 radial connector
- 10-32 tapped hole
- 42 grams
- -60 to +900°F (-51 to +482°C)
- Small size
- Charge mode



### Model 3443C: High Temperature Triaxial Accelerometer

- 2.7 pC/g sensitivity
- 10,000 Hz upper frequency range ( $\pm 10\%$ )
- (3) 10-32 radial connectors
- (2)  $\varnothing$ .15 thru hole mount
- 10 grams
- Titanium housing, hermetic seal
- -94 to +500°F (-70 to +260°C)
- Charge mode
- Uses (3) low noise cables for isolated outputs





# EXTREME ENVIRONMENTS

Dytran sensors go to extremes bringing you the data you need. The products in this section are examples of engineered solutions for challenging environments; contact our Applications Engineers today to see how we can help!

## Hazardous Environment

Products in this group are ATEX certified for use in potentially explosive atmospheres in compliance with EN 60079-0 and EN 60079-11. Certification documentation is on file for these products; ask our Applications Engineers for complete specifications and information.

### Model 2180M1: Acoustic Pressure Sensor

- 2,000 mV/psi sensitivity, 2.5 psi range
- 5,000 Hz frequency response range ( $\pm 5\%$ )
- 304L connector, 1" NPT (pipe thread) mount
- 155 grams
- High intensity acoustic sensor, internally ground isolated
- -60 to +250°F (-51 to +121°C)
- IEPE



### Model 2180M4: Acoustic Pressure Sensor

- 2,000 mV/psi sensitivity, 2.5 psi range
- 5,000 Hz frequency response range ( $\pm 5\%$ )
- 304L connector, 1" NPT (pipe thread) mount
- 155 grams
- High intensity acoustic sensor, internally ground isolated
- -60 to +250°F (-51 to +121°C)
- IEPE



### Series 2006V: IEPE Pressure Sensor

Available in 3 ranges: 50 psi, 100 psi, 500 psi

- Sensitivities (mV/psi): 100, 50, 10
- 8,000 psi maximum pressure
- 50 kHz resonant frequency
- 2-pin MIL-C-5015 axial connector
- 1/4-18 mounting thread
- 55 grams, case isolated
- -40 to +250°F (-40 to +121°C)
- Acceleration compensated
- Fast rise time, ATEX certified



### Model 3190A6: Cryogenic Accelerometer

- 100 mV/g sensitivity, 50g range
- 2 to 5,000 Hz frequency range ( $\pm 10\%$ )
- 3-pin radial connector
- 4-Bolt mounting
- 160 grams
- -320 to +250°F (-196 to 121°C)
- -24 VDC
- For cryogenic pump monitoring



## Moisture Resistant/Submersible

Moisture resistant products in this section are designed for continuous operation in high humidity and liquid splash environments. Submersible products feature Dytran exclusive Immersion Proof™ boot sealing technology for underwater studies of pumps, motors, propellers, marine structures, hull vibrations, and model basin studies.

### Model 3006A: Moisture Resistant Accelerometer

- 100 mV/g sensitivity, 50g range
- 0.32 to 5,000 Hz frequency range ( $\pm 5\%$ )
- 10-foot integral cable
- 10-32 tapped hole
- 12 grams
- Case isolated
- Splash proof boot
- -60 to +250°F (-51 to +121°C)
- IEPE



### Model 3243A: Moisture Resistant Triaxial Accelerometer

- 10 mV/g sensitivity, 500g range
- 1.5 to 10,000 Hz frequency range ( $\pm 5\%$ )
- 2-meter integral cable
- Adhesive mount
- 2.5 grams, lightweight
- Case isolated
- Moisture resistant
- -60 to +250°F (-51 to +121°C)
- IEPE



### Model 3217A: Submersible Accelerometer

- 100 mV/g sensitivity, 50g range
- 1 to 10,000 Hz frequency range ( $\pm 10\%$ )
- 10-foot integral cable
- Adhesive mount
- 5 grams
- Base isolated
- Lightweight
- Low noise
- Submersible to 175 psi
- -60 to +250°F (-51 to +121°C)
- IEPE



### Model 3220M34: Miniature Submersible IEPE Accelerometer

- 30 mV/g sensitivity, 166g range
- 1.6 to 5,000 Hz frequency range ( $\pm 5\%$ )
- 328-foot integral cable
- Adhesive mount
- 5 grams
- Excellent temperature stability
- -65 to +212°F (-54 to +100°C)
- Submersible to 175 psi



### Model 3220M36: Miniature Submersible IEPE Accelerometer

- 30 mV/g sensitivity, 166g range
- 1.6 to 5,000 Hz frequency range ( $\pm 5\%$ )
- 213-foot integral cable
- Adhesive mount
- 5 grams
- -65 to +212°F (-54 to +100°C)
- Excellent temperature stability
- Submersible to 175 psi





## Cryogenic

Dytran cryogenic accelerometers are designed for use in extreme cold to monitor performance of pumps, valves, and other machine elements installed in or near cryogenic liquids. These products function normally even when fully immersed in L<sub>n</sub>2. Note: Calibration under cryogenic conditions (using liquid nitrogen) is provided at time of shipment.

### Model 3306A1: Cryogenic Accelerometer

- 5 mV/g sensitivity; 1,000g range
- 4.8 to 1,800 Hz frequency range (±5%)
- 3-pin military Bayonet-style axial connector
- 1/4-28 stud mount
- 37 grams
- Case isolated
- -320°F (-196°C) operation
- Two-pole low pass filter
- Stable MOSFET amplifier technology
- -320 to +300°F (-195 to +149°C)
- IEPE



### Model 3045A: Cryogenic Accelerometer

- 5 mV/g sensitivity, 1,000g range
- 4.8 to 1,800 Hz frequency range (±5%)
- 10-32 axial connector
- 1/4-28 stud mount
- 20 grams, case isolated
- -320°F (-196°C) operation
- Two-pole low pass filter
- Stable MOSFET amplifier technology
- -320 to +300°F (-195 to +148°C)
- IEPE



### Model 3143M16: Cryogenic Triaxial Accelerometer

- 10 mV/g sensitivity, 500g range
- 1.6 to 5,000 Hz frequency range (±5%)
- 4-pin 3/8-28 Glenair radial connector
- 6-32 thru hole mount
- 50 grams
- Case isolated
- -320 to +250°F (-196 to +121°C)
- IEPE



### Model 3334A: Cryogenic Accelerometer

- 10 mV/g sensitivity, 500g range
- 1 to 10,000 Hz (±5%)
- 5-44 radial connector
- 5-40 stud mount
- 2 grams
- IEPE
- Miniature
- -320 to +250°F (-196 to +121°C)



## Down Hole

These products are for vibration and shock measurements in down-hole drilling applications. They are used to provide data to rock & soil strata detectors, and for pogo detection. Designed for high temperature environments encountered in drill heads and logging electronics pods. Small size allows installation in confined areas.

### Model 3089A: Miniature Accelerometer

- 10 mV/g sensitivity, 500g range
- 1 to 10,000 Hz (±10%)
- Integral cable
- Adhesive mount
- 0.6 grams
- Cost effective
- -60 to +250°F (-51 to +121°C)
- IEPE



### Model 3205B: High Temperature Accelerometer

- 2 mV/g sensitivity, 500g range
- 0.64 to 5,000 Hz frequency range (±3db)
- 35-inch integral cable
- Adhesive mount
- 2 grams
- +4.0 to +4.5 VDC power
- -40 to +347°F (-40 to +175°C)
- IEPE



### Model 3003B: Low Bias Miniature Triaxial Accelerometer

- 2 mV/g sensitivity, 500g range
- 2 to 5,000 Hz frequency range (±10%)
- 22-inch integral cable
- Adhesive mount
- 6 grams
- +4.0 to +5.5 VDC power
- -40 to +347°F (-40 to +175°C)
- Triaxial
- IEPE



### Model 3115M14: Miniature IEPE Accelerometer

- 10 mV/g sensitivity, 500g range
- 10 to 10,000 Hz frequency range (±3dB)
- Adhesive mount
- 1.4 grams
- +7.5 to +9.5 VDC power
- -60 to +350°F (-51 to +176°C)
- IEPE





# INDUSTRIAL MACHINERY CONDITION BASED MAINTENANCE

Machinery Condition Based Maintenance (CBM) programs rely on sensors that are up to the task of long-term installation in challenging industrial environments. Dytran CBM sensors with Immersion Proof™ cable sealing technology are field-proven to provide years of uninterrupted service, even in the worst conditions.

## General Predictive Maintenance



Sensors in this category are for use in standard factory conditions up to 250 degrees F. Monitor structural vibrations in conveyor systems, shafts and motor alignment, slow rotational speeds in the sub-1Hz range. Ideal for industrial fans, pumps, transmissions, and plant automation applications.

### Model 3019A: Industrial Accelerometer

- 10 mV/g sensitivity, 500g range
- 1 to 10,000 Hz frequency range ( $\pm 5\%$ )
- 10-32 axial connector
- 1/4-28 or 10-32 stud mount
- 8 grams
- Base isolated
- IEPE
- -60 to +300°F (-51 to +149°C)
- High frequency bearing analysis



### Model 3148E: Industrial Accelerometer

- 100 mV/g sensitivity, 50g range
- 0.5 to 5,000 Hz frequency range ( $\pm 5\%$ )
- BNC radial connector
- 10-32 tapped hole
- 48 grams
- Base isolated
- -60 to +250°F (-51 to +121°C)
- IEPE
- Walk around data collection
- Designed for use with magnetic mounting bases



### Model 3059A: Industrial Accelerometer

- 100 mV/g sensitivity, 50g range
- 0.3 to 8,000 Hz frequency range ( $\pm 3\text{db}$ )
- 2-pin radial connector
- 1/4-28 thru hole mount
- 73 grams
- Case isolated
- Low noise JFET electronics
- -60 to +250°F (-51 to +121°C)
- IEPE



### Model 3176B: Industrial Accelerometer

- 100 mV/g sensitivity, 50g range
- 0.3 to 10,000 Hz frequency range ( $\pm 10\%$ )
- 2-pin axial connector
- 10-32 or 1/4-28 tapped hole
- 44 grams
- Case isolated
- -60 to +250°F (-51 to +121°C)
- IEPE



### Model 3213D1: Industrial Triaxial Accelerometer

- 100 mV/g sensitivity, 50g range
- Axis 1 & 2: 2 to 7,000 Hz frequency range ( $\pm 3\text{dB}$ )
- Axis 3: 2 to 10,000 Hz frequency range ( $\pm 3\text{dB}$ )
- 4-pin radial connector
- 10-32 thru hole mount
- 65 grams
- Case isolated
- 360° cable orientation
- -60 to +250°F (-51 to +121°C)
- IEPE



### Series 3202A: Industrial Accelerometer

Available in 2 ranges: 10g, 50g

- 0.5 to 5,000 Hz frequency range ( $\pm 5\%$ )
- 2-pin radial connector
- 1/4-28 thru hole mount
- 160 grams
- Case isolated
- 360° cable orientation
- -60 to +250°F (-51 to +121°C)
- IEPE





## Immersion Proof™ Technology for Wet Environments

Dytran's unique Immersion Proof™ boot sealing technology lets you put sensors in the harshest industrial and shipboard environments. Immersion Proof™ products are designed for use in marine, sewage treatment, mining, construction, pulp and paper, and oilfield applications where cable connector sealing is paramount for long-term operation.

### Series 3166B: Industrial Accelerometer

Available in 3 ranges: 10g, 50g, 500g

- Sensitivities (mV/g): 500, 100, 10
- 0.3 to 5,000 Hz frequency range ( $\pm 5\%$ )
- 2-pin radial connector, 1/4-28 thru hole mount
- 228 grams
- Case isolated, 360° cable orientation
- Low profile
- Designed for use with water & oil resistant environmental boot
- -60 to +250°F (-51 to +121°C)
- IEPE



### Model 3185D: Industrial Accelerometer

- 100 mV/g sensitivity, 50g range
- 2 to 10,000 Hz frequency range ( $\pm 10\%$ )
- TNC axial connector, 1/4-28 tapped hole
- 55 grams
- Base isolated
- Internal Faraday shield
- Designed for use with water & oil resistant environmental boot
- -60 to +250°F (-51 to +121°C)
- IEPE



### Model 3184E: Industrial Accelerometer

- 100 mV/g sensitivity, 50g range
- 1 to 5,000 Hz frequency range ( $\pm 5\%$ )
- 2-pin axial connector, 1/4-28 tapped hole
- 120 grams
- Case isolated
- Internal Faraday shield
- Designed for use with water & oil resistant environmental boot
- -60 to +250°F (-51 to +121°C)
- IEPE



### Model 3063B: Industrial Triaxial Accelerometer

- 100 mV/g sensitivity, 50g range
- 0.5 to 3,000 Hz frequency range ( $\pm 5\%$ )
- 4-pin Bayonet style radial connector, 1/4-28 thru hole mount
- 113 grams
- Case isolated, internal Faraday shield
- Designed for use with water & oil resistant environmental boot
- -60 to +250°F (-51 to +121°C)
- IEPE



## Bridge, Building & Large Structure Permanent Monitoring

High sensitivity IEPE accelerometers for monitoring low frequency, seismic motion, and resonances in large-scale civil engineering applications. Sensors in this category are designed for long-term structural health monitoring studies, and for permanent installation in modern seismic monitoring systems incorporated into building designs.

### Model 3187D: Industrial Accelerometer

- 500 mV/g sensitivity, 10g range
- 0.48 to 1,000 Hz frequency range ( $\pm 5\%$ )
- 2-pin axial connector
- 1/4-28 tapped hole
- 122 grams
- Case isolated
- Designed for use with water & oil resistant environmental boot
- -60 to +250°F (-51 to +121°C)
- IEPE



### Series 3191A: Industrial Accelerometer

Available in 2 ranges: 0.5g, 1g

- Sensitivities (mV/g): 10,000; 5,000
- 0.08 to 1,000 Hz frequency range ( $\pm 5\%$ )
- 2-pin axial connector
- 1/4-28 tapped hole
- 775 grams
- Case isolated, internal Faraday shield
- Designed for use with water & oil resistant environmental boot
- -60 to +250°F (-51 to +121°C)
- IEPE



### Model 3192A: Industrial Accelerometer

- 1,000 mV/g sensitivity, 5g range
- 0.5 to 1,000 Hz frequency range ( $\pm 5\%$ )
- 2-pin axial connector
- 1/4-28 tapped hole
- 190 grams
- Case isolated
- Internal Faraday shield
- Low frequency response
- -60 to +250°F (-51 to +121°C)
- IEPE



### Series 3233A: Triaxial Accelerometer

Available in 2 ranges and TEDS: 5g, 1,000g

- Axis 1 & 2: 0.3 to 3,000 Hz frequency range ( $\pm 10\%$ )
- Axis 3: 0.3 to 6,000 Hz frequency range ( $\pm 10\%$ )
- 4-pin 1/4-28 radial connector
- Thru hole mount
- 30 grams
- Base isolated
- 360° cable orientation
- Ultra high sensitivity
- -60 to +200°F (-51 to +93°C)
- IEPE





# DYNAMIC FORCE SENSORS

Dytran piezoelectric force sensors are used to define a wide range of fast-transient dynamic events encountered in testing activities such as drop testing of protective headgear and helmets, stamping, forming, reciprocating tool development, "air cannon" projectile impacts to test articles, end-of-line testing for product shock survivability, and for shaker driving point. These rugged quartz and ceramic sensors exhibit high stiffness and contain no moving parts, making them ideal for real-world industrial environments as well as for the test lab.

## Modal Analysis and Process Control



### Model 1022V: Ultra Miniature IEPE Force Sensor

- 100 mV/LbF sensitivity
- 50 LbF compression range
- 50 LbF tension range
- 100 LbF maximum compression
- 75 LbF maximum tension
- 5-foot integral cable
- 10-32 tapped holes top and bottom
- 4.5 grams, miniature size
- -100 to +250°F (-73 to +121°C)
- IEPE



### Series 1053V: IEPE Force Sensor

Available in 6 ranges: 1 LbF; 10 LbF; 50 LbF; 100 LbF; 500 LbF; 1,000 LbF

- Sensitivities (mV/LbF): 500, 100, 50, 10, 5, 1
- 10-32 radial connector
- 10-32 tapped holes top and bottom
- 28 grams
- High natural frequency
- -100 to +250°F (-73 to +121°C)
- IEPE



### Series 1050C: Charge Mode Force Sensor

- -18 pC/LbF sensitivity
- 10-32 axial connector
- 1/4-28 tapped hole top surface
- 32 grams
- -100 to +500°F (-73 to +260°C)
- Charge mode



### Series 1051V: IEPE Force Sensor

Available in 6 ranges and high temp: 1 LbF; 10 LbF; 50 LbF; 100 LbF; 500 LbF; 1,000 LbF

- Sensitivities (mV/LbF): 500, 100, 50, 10, 5, 1
- 10-32 radial connector
- 1/4-28 tapped holes top and bottom
- 28 grams
- High natural frequency
- -100 to +250°F (-73 to +121°C)
- IEPE



### Series 1060V: IEPE Force Sensor

Available in 6 ranges: 500 LbF; 1,000 LbF; 5,000 LbF; 10,000 LbF; 25,000 LbF; 50,000 LbF

- Sensitivities: 10 mV/LbF, 5 pC/LbF, 1 mV/LbF, 0.5 mV/LbF, 0.2 mV/LbF, 0.1 mV/LbF
- 10-32 axial connector
- 3/8-16 tapped hole top surface
- 460 grams
- Wide frequency range
- -100 to +250°F (-73 to +121°C)
- IEPE



### Series 1061V: IEPE Force Sensor

6 ranges: 500 LbF; 1,000 LbF; 5,000 LbF; 10,000 LbF; 25,000 LbF; 50,000 LbF

- Sensitivities (mV/LbF): 10, 5, 1, 0.5, 0.2, 0.1
- 10-32 radial connector
- 3/8-16 tapped hole top and bottom
- 452 grams
- Wide frequency range
- -100 to +250°F (-73 to +121°C)
- IEPE



## Force Link and Machinery Studies



### Series 1203V: Ring Style Force Sensor

5 ranges: 100 LbF; 500 LbF; 1,000 LbF; 5,000 LbF; 10,000 LbF

- Sensitivities (mV/lbf): 50, 10, 5, 1, 0.5
- 10-32 radial connector
- Ø.40 inch (10.2 millimeter) thru hole
- 50 grams, ring style configuration
- -100 to +250°F (-73 to +121°C)
- IEPE



### Series 1210C: High Temperature Force Sensor

7 ranges: 5,000 LbF; 10,000 LbF; 20,000 LbF; 40,000 LbF; 60,000 LbF; 80,000 LbF; 100,000 LbF

- 18 pC/LbF Sensitivity
- 10-32 radial connector
- Ø.26 inch (Ø.7 millimeter) thru hole mount
- 12 grams
- Ring style configuration
- +400°F (+204°C) operation
- -60 to +400°F (-51 to +204°C)
- Charge mode





# DYNAMIC PRESSURE SENSORS

Piezoelectric pressure sensors have been used to measure AC coupled, fast rise-time, transient, and high frequency dynamic events since the early 1950's. Rugged Dytran quartz and ceramic pressure sensors measure transient or AC pulses in air and in closed hydraulic and pneumatic systems, including cavitations and sudden spikes or surges in systems where an existing static pressure could mask dynamic events. Sound pressure events in air such as blast wave, airbag deployment, or high noise can also be measured with high sensitivity dynamic pressure sensors.

## General Purpose

### Model 2005V: IEPE Industrial Pressure Sensor

- 100 mV/psi sensitivity, 50 psi range
- 1,000 psi maximum pressure
- 90 kHz resonant frequency
- TNC axial connector
- 1/8-27 mounting thread
- 43 grams
- Base isolated
- -100 to +275°F (-73 to +135°C)
- IEPE



### Series 2006V: IEPE Pressure Sensor

Available in 3 ranges: 50 psi, 100 psi, 500 psi

- Sensitivities (mV/psi): 100, 50, 10
- 8,000 psi maximum pressure
- 50 kHz resonant frequency
- 2-pin MIL-C-5015 axial connector
- 1/4-18 mounting thread
- 55 grams
- Case isolated
- Acceleration compensated
- Fast rise time, ATEX certified
- -40 to +250°F (-40 to +121°C)
- IEPE



### Model 2013D: IEPE Sound Pressure Sensor

- 2,000 mV/psi sensitivity, 2.5 psi range
- 20 psi maximum pressure
- 50 kHz resonant frequency
- 10-32 axial connector
- 3/4-16 mounting thread adaptor
- 24 grams
- Fast rise time
- High natural frequency
- -60 to +250°F (-51 to +121°C)
- IEPE



### Model 2180C: Charge Mode, High Sensitivity

- 600 pC/psi sensitivity, 10 psi range
- 600 psi maximum pressure
- 21 kHz resonant frequency
- TNC axial connector
- 1 1/8-12 mounting thread
- Base isolated
- Acceleration compensated
- -60 to +500°F (-51 to +260°C)
- Charge mode



## Dynamic Pressure Measurements

### Series 2200C: High Temperature

7 ranges: 100 psi; 500 psi; 1,000 psi; 5,000 psi; 10,000 psi; 15,000 psi

- 1 pC/psi sensitivity
- 10-32 axial connector
- 5/16-24 mounting thread
- 7 grams
- Ultra fast rise time
- Acceleration compensated
- -100 to +500°F (-73 to +260°C)
- Charge mode



### Series 2300C: Charge Mode Pressure Sensor

7 ranges: 100 psi; 500 psi; 1,000 psi; 3,000 psi; 5,000 psi; 10,000 psi; 15,000 psi

- 0.35 pC/psi sensitivity
- 10-32 axial connector
- 5/16-24 mounting thread
- 6.5 grams
- Ultra fast rise time
- Acceleration compensated
- -100 to +500°F (-73 to +260°C)
- Charge mode
- IEPE series available



### Series 2301B: IEPE Pressure Sensor

6 ranges: 250; 500; 1,000; 5,000; 10,000; 15,000

- Sensitivities (mV/psi): 20, 10, 5, 1, 0.5, 0.33
- 10-32 axial connector
- 5/16-24 mounting thread
- 5 grams
- High natural frequency
- Floating clamp nut
- Acceleration compensated
- -100 to +250°F (-73 to +121°C)
- IEPE
- Charge mode versions available



### Series 2200V1: IEPE Pressure Sensor

- 50 mV/psi, 100 psi range
- 1,000 psi maximum pressure
- 300 kHz resonant frequency
- 10-32 axial connector
- 5/16-24 mounting thread
- 6 grams
- Acceleration compensated
- IEPE





# ELECTRONICS/ SIGNAL CONDITIONING

For those requiring analog front-end conditioning, Dytran produces a wide range of cost-effective IEPE power units, in-line charge amplifiers, vibration meters and signal conditioners for DC MEMS sensors. Choose from a wide variety of configurations to best suit your dynamic testing environment. Note: Dytran IEPE, charge mode, and DC MEMS sensors are compatible with all manufacturers of data acquisition systems that provide built-in sensor power or signal conditioning, and they are fully compatible with units offered by other manufacturers.

## Battery Operated IEPE Current Source Power Units

Portable or ride-along dynamic measurements made easy with these small, affordable, battery operated single and three channel IEPE power units. All of the models in this section use two 9V dry cell batteries and all feature a front-panel mounted voltmeter to monitor bias voltage of the sensor and to indicate battery condition. Momentary pushbutton on front panel allows bias voltage check without disturbing the test.

### 4102C: Single Channel Unity Gain

- Battery powered
- 2 mA constant current
- BNC jack input connector
- BNC jack output connector



### 4103B: Three Channel Unity Gain

- Battery powered
- 2 mA constant current
- BNC jack input connectors
- BNC jack output connectors



### 4105B: Single Channel Gain x1, x10, x100

- Battery powered, 2 mA constant current
- Single channel, gain x1, x10, x100
- BNC jack input connector, BNC jack output connector



## Bench-Top, Line-Operated IEPE Current Source Power Units

This selection of slim-line, bench-top, 110VAC power units provides a stable, versatile, source for IEPE power without taking up a lot of room on your test stand. These units are used in laboratory and environmental test lab environments to provide power to IEPE sensors used in chambers, shakers, drop-test stands, and other testing apparatus, as well as in dedicated "end-of-line" testing applications. They are also recommended for use in high-temperature "hybrid" measurement systems consisting of a non-amplified PE sensor in combination with an in-line charge amplifier.

### 4110C: Single Channel, Zero Clamp

- Line powered, single channel
- 2-20 mA adjustable current
- With zero clamp, eliminates AC-coupled baseline drift
- BNC jack input connectors
- BNC jack output connectors



### 4112B: Single Channel, Gain x1, x10, x100

- Line powered, single channel
- Gain x1, x10, x100
- Buffered output
- BNC jack input connector
- BNC jack output connector



### 4114B1: 4-Channel, Unity Gain

- Line powered, 4 channel
- 2-20 mA adjustable current
- BNC jack input connectors
- BNC jack output connectors
- For driving long cables



### 4115B: AC/DC Coupled Zero Adjust

- Line powered, single channel
- Adjustable current, AC/DC coupled
- Buffered output, zero adjustable
- BNC jack input connector, BNC jack output connector



## Rack Mounted IEPE Signal Conditioners

Dytran 19" wide rack mounted current source power units are ideal for laboratory and field applications where high quantity sensor channel counts are required.

### 4116: 16 Channel, Unity Gain



- Line powered, 16 channel rack
- Adjustable drive current

### 4121: 12 Channel, Unity Gain



- Line powered, 12 channel rack
- Adjustable current, Six channel: 4120

### 4123B: With Gain x1, x10, x100



- Line powered, 12 channel rack; with gain x1, x10, x100
- Buffered output, six channel: 4122B





## In-Line Charge Amplifiers/TEDS Adapter

Use with IEPE power units and charge mode sensors in high temperature applications.

### 4752B: In-Line Charge Amplifier

Available with TEDS

- 500 pC range, 10 mV/pC
- 10-32 jack input and output
- 17 grams



### 4711A Series: In-Line Charge Amplifier

Available in 3 ranges: 500 pC; 5,000 pC; 50,000 pC

- 50,000 pC range, 0.1 mV/pC
- 10-32 jack to BNC plug, 33 grams



### 4751B Series: In-Line Charge Amplifier

Available in 4 ranges: and TEDS 100 pC; 500 pC; 5,000 pC; 50,000 pC

- 50 mV/pC
- 10-32 jack to 10-32 jack
- 25 grams



### 4705A Series: In-Line Charge Amplifier

Available in 4 ranges: 100 pC; 500 pC; 5,000 pC; 50,000 pC

- 100 pC range, 50 mV/pC
- BNC jack to BNC jack
- 33 grams



### 4753B Series: In-Line Charge Amplifier

Available in 2 ranges: 500 pC; 5,000 pC

- 10 mV/pC
- 10-32 jack to BNC jack
- 25 grams



### Model 4754B: In-Line Charge Amplifier

- 10 mV/pC sensitivity, 500 pC range
- 10-32 jack to 10-32 jack
- 17 grams



## Specialty

### 4020: Dual IEPE/Charge Mode Signal Conditioner

- Line powered, 3 channel
- For IEPE or charge mode sensors
- BNC jack input connectors
- BNC jack output connectors



### 4010: Signal Conditioner for DC MEMS Sensors

- Line powered, 3 channel
- For bridge type or differential sensors
- D-SUB input connectors
- BNC output connectors



### 4025A: In-Line TEDS Adapter

- Converts non-TEDS IEPE sensors to TEDS operation
- BNC jack input connector
- BNC plug output connector



### 4139: Airborne IEPE Power Unit

- 6 channel
- Operates from +28 VDC aircraft power
- 10-32 jack input connectors
- DA-15P output connector



### 4007: IEPE Board-Level Current Source

- 4 channel IEPE signal conditioner,
- AC and RMS DC outputs
- 3 khz and 10 khz low pass filter options
- One channel logical output
- For OEM installations



### 4151HL Series: Vibration Meter

Available with 2 kHz and 5 kHz low pass filter

- Line powered, single channel
- True RMS vibration monitoring/controller
- Settable high/low limit
- 0-10 VDC output



### 4016: Signal Conditioner, Single Channel, Dual Mode

- Signal conditioner, dual mode: Supports both IEPE and PE sensors (single ended and differential)
- Microprocessor controlled
- Adjustable gain
- High pass/low pass filtering
- Adjustable drive current
- Rack mountable with daisy chainable power
- Runs on external 12VDC in (external transformer supplied)
- Chassis: 5.6 x 1.7 x 3.6 inches

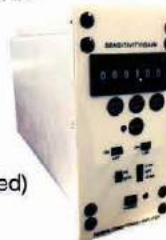

### 4190: Portable Vibration Meter

- Large digital display, hand held
- Battery powered, low battery indicator
- Use with 10 or 100 mV/g IEPE accelerometers
- Range selectable (2, 20, 50 g's full scale)
- Measures sensor "Bias Voltage" for sensor health check
- BNC output jack to monitor sensor output waveform





# HOW TO GET MORE INFORMATION

## Searching a Product on the Website



To get more information on any of the products in this guide, please visit our website at [www.dytran.com](http://www.dytran.com). You can also call a member of our friendly sales team at **818-700-7818**.

### 1. Go to [www.dytran.com](http://www.dytran.com)

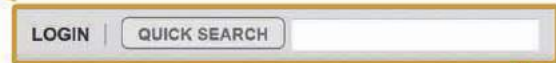

### 2. Type the model number or application in the search box



or



### 3. Select a product

**REFINE RESULTS** **SEARCH PRODUCTS**  
Expand Your Result  
Remove Keyword: 3055D  
Narrow by Category  
Accelerometers (12)

Search Results For '3055D'  
Sort: By Name (A - Z)

 <b>MODEL 3055D1, GENERAL PURPOSE ACCELEROMETER</b> 10 mV/g, 600g range, 10-32 radial connector, 10-32 tapped hole, 10 grams, cost effective, general purpose	 <b>MODEL 3055D1T, GENERAL PURPOSE ACCELEROMETER WITH TEDS</b> 10 mV/g, 500g range, 10-32 radial connector, 10-32 tapped hole, 10 grams, cost effective, TEDS, general purpose	 <b>MODEL 3055D2, GENERAL PURPOSE ACCELEROMETER</b> 100 mV/g, 60g range, 10-32 radial connector, 10-32 tapped hole, 10 grams, cost effective, general purpose
---	--	---

### 4. View product overview & click on **Download PDF**, **3D Model**, and **RFQ**

**MODEL 3055D1, GENERAL PURPOSE ACCELEROMETER**  
Model# 3055D1

**FEATURES:**

- 10 mV/g sensitivity
- 600g range
- 10-32 radial frequency range (±10%)
- 10-32 radial connector
- 10-32 tapped hole
- 10 grams
- Titanium
- Hermetically sealed
- Data filtered
- IP67

**APPLICATIONS:**

- Bridge analysis
- Vibration control
- General purpose vibration monitoring

**DESCRIPTION**

The Dytran model 3055D1 is a cost effective, single axis ICP accelerometer offering over a sensitivity of 10 mV/g.

Design of the model 3055D1 requires a standard mass loading element designed with a rugged titanium housing, and incorporates a 10-32 radial connector and 10-32 axial mounting capabilities. Model 3055D1 is best suited to local EMI/RFI and the harsh and corrosive environments. It is also hermetically sealed for superior performance in high humidity and other extreme conditions.

**DOWNLOAD PDF** **3D MODEL** **RFQ**

Features & applications

Detailed product overview



# HOW TO READ THE SPEC TABLES

## Understanding the Next Section

The next section of the Dytran Sensor Selector Guide groups the products into easy-to-read tables for side-by-side comparison of all products by configuration types or by general application areas. For example, in this section you can view all triaxial accelerometers side-by-side, no matter what industry or application area they were originally designed for. This allows you to select from the broadest possible spectrum of similar products when searching for the perfect sensor!

### Model Category

General Purpose



Base model number of the series

Specs that belong to the base model

Notable feature of the model

Model Number	3055D1	3056D1
Weight, ounces (grams)	0.35 (10)	0.35 (10)
Size, inches (L x W x H)	0.50 x 0.62 (D x H)	0.50 x 0.93 (D x H)
Connector Type	10-32 radial	10-32 axial
Mounting Method	10-32 tapped hole	10-32 tapped hole
Sensitivity, mV/g (mV/m/s <sup>2</sup> )	10 (1)	10 (1)
Full Scale Range, g (m/s <sup>2</sup> )	500 (4,903)	500 (4,905)
Frequency Response, ±5%, Hz	1 to 10,000	1 to 10,000 (±10%)
Maximum Shock Survivability, g (m/s <sup>2</sup> )	3,000 (29,420)	3,000 (29,420)
Operating Temperature Range, °F (°C)	-60 to +250 (-51 to +121)	-60 to +250 (-51 to +121)
Environmental Seal	hermetic	hermetic
Electrical Isolation	base	base
Compatible Cables	6010A, 6011A	6010A, 6011A
Features	cost effective	cost effective
Additional Series Variations	3055D2: 100 mV/g, 50g range 3055D3: 500 mV/g, 10g range 3055D4: 50 mV/g, 100g range 3055D5: 20 mV/g, 250g range 3055D6: 200 mV/g, 25g range	3056D2: 100 mV/g, 50g range 3056D3: 500 mV/g, 10g range 3056D4: 20 mV/g, 250g range 3056D5: 50 mV/g, 100g range 3056D6: 200 mV/g, 25g range 3056D7: 1 mV/g, 5,000g range 3056D8: 5 mV/g, 1,000g range
Similar Series	3055DT: TEDS 3055C: charge mode, 15 pC/g	3056DT: TEDS 3056C: charge mode, 15 pC/g

Models that belong to this family series, but with different sensitivities and full-scale ranges

Similar models that belong to the base family but with different features



### Airborne



Model Number	3062A	3077A	3078A	3079A
Weight, ounces z(grams)	1.31 (37)	0.39 (11)	0.71 (20)	0.39 (11)
Size, inches (L x W x H)	0.75 x 1.4 (D x H)	0.67 x 0.80 x 0.40	0.80 x 1.05 x 0.41	1.09 x 0.80 x 0.41
Connector Type	3-pin bayonet-style axial	3-foot integral cable to flying leads	5-foot integral cable to flying leads	14-foot integral cable to flying leads
Mounting Method	1/4-28 stud	Ø.312 thru hole	Ø.312 thru hole	Ø.257 thru hole
Sensitivity, mV/g (mV/m/s <sup>2</sup> )	10 (1)	10 (1)	10 (1)	10 (1)
Full Scale Range, g (m/s <sup>2</sup> )	500 (4,903)	500 (4,903)	500 (4,903)	500 (4,903)
Frequency Response, ±5%, Hz	0.48 to 10,000	1.1 to 5,000 (±10%)	0.7 to 5,000 (±10%)	1.1 to 5,000 (±10%)
Maximum Shock Survivability, g (m/s <sup>2</sup> )	5,000 (49,033)	3,000 (29,420)	3,000 (29,420)	3,000 (29,420)
Operating Temperature Range, °F (°C)	-60 to +305 (-51 to +152)	-60 to +250 (-51 to +121)	-60 to +250 (-51 to +121)	-60 to +250 (-51 to +121)
Environmental Seal	hermetic	hermetic	hermetic	hermetic
Electrical Isolation	case	case	case	case
Compatible Cables	-	-	-	-
Features	spark-plug shaped package	integral mounting bracket	integral mounting bracket	integral mounting bracket
Additional Series Variations	3062A1: 25 mV/g, 200g range	multiple cable lengths available	multiple cable lengths available	multiple cable lengths available
Similar Series	3062B1: 25 mV/g, 200g range, 1/4-28 stud mount (0.36-inches long)	multiple sense directions available	multiple sense directions available	multiple sense directions available

### Airborne



Model Number	3091A	3168F	3232A1	3236A
Weight, ounces (grams)	1.06 (30)	0.81 (23)	1.59 (45)	0.99 (28.1)
Size, inches (L x W x H)	1.21 x 1.05 x 0.41	0.80 x 0.50 (D x H)	1.0 x 1.1 x 0.51	0.80 x 0.52 (D x H)
Connector Type	3-pin "Mighty Mouse®" radial	48-inch integral cable to flying leads	3-pin "Mighty Mouse®" radial	3-pin "Mighty Mouse®" radial
Mounting Method	Ø.312 thru hole	8-32 thru hole	Ø.268 thru hole	Ø.169 thru hole
Sensitivity, mV/g (mV/m/s <sup>2</sup> )	10 (1)	10 (1)	10 (1)	10 (1)
Full Scale Range, g (m/s <sup>2</sup> )	500 (4,903)	500 (4,903)	500 (4,903)	500 (4,903)
Frequency Response, ±5%, Hz	10 to 1,000	1 to 20,000	3.3 to 2,500 (±10%)	1.2 to 10,000
Maximum Shock Survivability, g (m/s <sup>2</sup> )	3,000 (29,420)	3,000 (29,420)	5,000 (49,033)	10,000 (98,067)
Operating Temperature Range, °F (°C)	-60 to +250 (-51 to +121)	-60 to +250 (-51 to +121)	-60 to +250 (-51 to +121)	-60 to +300 (-51 to +149)
Environmental Seal	hermetic	hermetic	hermetic	hermetic
Electrical Isolation	case	case	case	case
Compatible Cables	-	-	6891A	-
Features	integral mounting bracket	high frequency response 360° cable orientation	biaxial integral mounting bracket	360° cable orientation

## Airborne



Model Number	3237A2	3302A	3315A	3326A1
Weight, ounces (grams)	1.31 (37)	1.06 (30)	1.73 (49)	0.35 (10)
Size, inches (L x W x H)	0.81 x 1.16 (D x H)	1.05 x 1.21 x 0.48	0.76 x 0.76 x 0.80	1.11 x 0.60 x 0.42
Connector Type	military-style D38999 axial	3-pin "Mighty Mouse®" radial	2-pin bayonet-style radial	1/4-28 4-pin radial
Mounting Method	1/4-28 stud	Ø.312 thru hole	1/4-28 tapped hole	Ø.162 thru hole
Sensitivity, mV/g (mV/m/s <sup>2</sup> )	25 (2.5)	10 (1)	20 (2)	10 (1)
Full Scale Range, g (m/s <sup>2</sup> )	200 (1,961)	500 (4,903)	250 (2,452)	500 (4,903)
Frequency Response, ±5%, Hz	0.48 to 10,000	10 to 1,000	0.5 to 10,000 (±3dB)	4 to 2,000
Maximum Shock Survivability, g (m/s <sup>2</sup> )	3,000 (29,420)	3,000 (29,420)	5,000 (49,033)	4,000 (39,227)
Operating Temperature Range, °F (°C)	-60 to +305 (-51 to +152)	-60 to +250 (-51 to +121)	-60 to +250 (-51 to +121)	-60 to +225 (-51 to +107)
Environmental Seal	hermetic	hermetic	hermetic	hermetic
Electrical Isolation	case	case	case	case
Compatible Cables	-	6891A	-	6937A
Features	spark-plug shaped package	biaxial integral mounting bracket	low noise JFET electronics low profile	compatible with standard aircraft on-board power supplies (+20 to +32 VDC) 360° cable orientation
Additional Series Variations	-	-	-	3326A2: 100 mV/g, 50g range
Similar Series	-	-	-	-

## General Purpose



Model Number	3049E	3055D1	3056D1	3100D24
Weight, ounces (grams)	(0.12) 3.3	0.35 (10)	0.35 (10)	1.94 (55)
Size, inches (L x W x H)	0.48 x 0.57 (D x H)	0.50 x 0.62 (D x H)	0.50 x 0.93 (D x H)	0.63 x 1.16 (D x H)
Connector Type	10-32 axial	10-32 radial	10-32 axial	10-32 radial
Mounting Method	10-32 stud	10-32 tapped hole	10-32 tapped hole	10-32 tapped hole
Sensitivity, mV/g (mV/m/s <sup>2</sup> )	10 (1)	10 (1)	10 (1)	1,000 (102)
Full Scale Range, g (m/s <sup>2</sup> )	500 (4,903)	500 (4,903)	500 (4,905)	5 (49)
Frequency Response, ±5%, Hz	1 to 10,000	1 to 10,000	1 to 10,000 (±10%)	1 to 1,000
Maximum Shock Survivability, g (m/s <sup>2</sup> )	5,000 (49,033)	3,000 (29,420)	3,000 (29,420)	200 (1,961)
Operating Temperature Range, °F (°C)	-60 to +250 (-51 to +121)	-60 to +250 (-51 to +121)	-60 to +250 (-51 to +121)	-60 to +250 (-51 to +121)
Environmental Seal	hermetic	hermetic	hermetic	hermetic
Electrical Isolation	base	base	base	case
Compatible Cables	6010A, 6011A	6010A, 6011A	6010A, 6011A	6010A, 6011A
Features	lightweight	cost effective	cost effective	high sensitivity
Additional Series Variations	3049E2: 100 mV/g, 50g range	3055D2: 100 mV/g, 50g range 3055D3: 500 mV/g, 10g range 3055D4: 50 mV/g, 100g range 3055D5: 20 mV/g, 250g range 3055D6: 200 mV/g, 25g range	3056D2: 100 mV/g, 50g range 3056D3: 500 mV/g, 10g range 3056D4: 20 mV/g, 250g range 3056D5: 50 mV/g, 100g range 3056D6: 200 mV/g, 25g range 3056D7: 1 mV/g, 5,000g range 3056D8: 5 mV/g, 1,000g range	-
Similar Series	3049E1/E3: adhesive mount, available in sensitivities of 10 and 100 mV/g 3049D: charge mode, 5.8 pC/g, available with adhesive or 10-32 stud mount	3055DT: TEDS 3055C: charge mode, 15 pC/g	3056DT: TEDS 3056C: charge mode, 15 pC/g	3100D24T: TEDS



### General Purpose



Model Number	3211A1	3214A1	3215M1	3234A1
Weight, ounces (grams)	0.35 (10)	0.39 (11)	0.35 (10)	0.42 (12)
Size, inches (L x W x H)	0.80 x 0.60 x 0.41	0.50 x 0.50 x 0.57	0.96 x 0.60 x 0.42	0.50 x 0.50 x 0.62
Connector Type	10-32 radial	10-32 radial	10-32 radial	10-32 radial
Mounting Method	Ø.171 thru hole	10-32 tapped hole	Ø.190 thru hole	10-32 tapped hole
Sensitivity, mV/g (mV/m/s <sup>2</sup> )	10 (1)	10 (1)	10 (1)	10 (1)
Full Scale Range, g (m/s <sup>2</sup> )	500 (4,903)	500 (4,903)	500 (4,903)	500 (4,903)
Frequency Response, ±5%, Hz	1 to 10,000	1 to 10,000	1 to 10,000	1 to 10,000
Maximum Shock Survivability, g (m/s <sup>2</sup> )	5,000 (49,033)	5,000 (49,033)	5,000 (49,033)	5,000 (49,033)
Operating Temperature Range, °F (°C)	-60 to +250 (-51 to +121)	-60 to +250 (-51 to +121)	-60 to +300 (-51 to +149)	-60 to +250 (-51 to +121)
Environmental Seal	hermetic	hermetic	hermetic	hermetic
Electrical Isolation	case	no	case	base
Compatible Cables	6010A, 6011A	6010A, 6011A	6010A, 6011A	6010A, 6011A
Features	360° cable orientation low noise	unique cubic design cost effective	360° cable orientation	unique cubic design low noise JFET electronics
Additional Series Variations	3211A2: 100 mV/g, 50g range	3214A2: 100 mV/g, 50g range 3214A3: 500 mV/g, 10g range	-	3234A2: 100 mV/g, 50g range 3234A3: 500 mV/g, 10g range
Similar Series	3211M1: submersible, 10-foot integral cable, 10 mV/g, 500g range	3214AT: TEDS	-	-

### General Purpose



Model Number	3255A1	3256A1	3312A2T
Weight, ounces (grams)	0.35 (10)	0.35 (10)	0.88 (25)
Size, inches (L x W x H)	0.50 x 0.62 (D x H)	0.50 x 0.91 (D x H)	0.75 x 0.73 (D x H)
Connector Type	10-32 radial	10-32 axial	10-32 radial
Mounting Method	10-32 tapped hole	10-32 tapped hole	10-32 tapped hole
Sensitivity, mV/g (mV/m/s <sup>2</sup> )	10 (1)	10 (1)	100 (10)
Full Scale Range, g (m/s <sup>2</sup> )	500 (4,903)	500 (4,903)	50 (490)
Frequency Response, ±5%, Hz	1 to 10,000	1 to 10,000	0.1 to 4,000
Maximum Shock Survivability, g (m/s <sup>2</sup> )	3,000 (29,420)	3,000 (29,420)	10,000 (98,067)
Operating Temperature Range, °F (°C)	-60 to +250 (-51 to +121)	-60 to +250 (-51 to +121)	-65 to +250 (-54 to +121)
Environmental Seal	hermetic	hermetic	hermetic
Electrical Isolation	no	no	no
Compatible Cables	6010A, 6011A	6010A, 6011A	6010A, 6011A
Features	cost effective	cost effective	ultra low frequency response low profile design TEDS
Additional Series Variations	3255A2: 100 mV/g, 50g range 3255A3: 500 mV/g, 10g range 3255A4: 50 mV/g, 100g range 3255A5: 20 mV/g, 250g range 3255A6: 200 mV/g, 25g range	3256A2: 100 mV/g, 50g range 3256A3: 500 mV/g, 10g range 3256A4: 20 mV/g, 250g range 3256A5: 50 mV/g, 100g range 3256A6: 200 mV/g, 25g range	-
Similar Series	3255C: charge mode, 15 pC/g	3256BT: TEDS 3256C: charge mode, 15 pC/g	-

High  
Temperature

Model Number	3030C1	3035C	3049D	3055C
Weight, ounces (grams)	0.24 (6.8)	0.09 (2.5)	0.14 (4)	0.21 (6)
Size, inches (L x W x H)	0.41 x 0.67 (D x H)	0.28 x 0.33 (D x H)	0.48 x 0.57 (D x H)	0.50 x 0.67 (D x H)
Connector Type	10-32 axial	5-44 radial	10-32 axial	10-32 radial
Mounting Method	10-32 stud	5-40 stud	10-32 stud	10-32 tapped hole
Sensitivity, pC/g (pC/m/s <sup>2</sup> )	0.4 (0.04)	2.5 (0.25)	5 (0.5)	15 (1.5)
Upper Frequency Response, ±5%, Hz	5,000	10,000 (±10%)	8,000	5,000
Maximum Shock Survivability, g (m/s <sup>2</sup> )	3,000 (29,420)	10,000 (98,067)	2,000 (19,613)	3,000 (29,420)
Operating Temperature Range, °F (°C)	-100 to +500 (-73 to +260)	-100 to +400 (-73 to +204)	-100 to +350 (-73 to +177)	-60 to +375 (-51 to +191)
Environmental Seal	hermetic	hermetic	hermetic	hermetic
Electrical Isolation	no	no	base	base
Compatible Cables	6013A, 6019A	6025A, 6056A	6013A, 6019A	6013A, 6019A
Features	HALT/HASS industry standard	miniature	lightweight	cost effective
Additional Series Variations	-	-	-	-
Similar Series	3030B: IEPE, 10-32 stud mount, 10 mV/g 3030BG: IEPE, adhesive mount, 10 mV/g 5310M1: IEPE, high temperature vibration measurement system, 10 mV/g 5310M2: IEPE, high temperature vibration measurement system, 5 mV/g	3035CG: adhesive mount 3035B: IEPE, 5-40 stud mount, available with sensitivities from 5 to 100 mV/g 3035BG: IEPE, adhesive mount, available with sensitivities from 5 to 100 mV/g	3049D1: adhesive mount 3049E/E2: IEPE, 10-32 stud mount, available in sensitivities of 10 and 100 mV/g 3049E1/E3: IEPE, adhesive mount, available in sensitivities of 10 and 100 mV/g	3055D: IEPE, available in sensitivities from 10 to 500 mV/g

High  
Temperature

Model Number	3056C	3085C	3088C	3092C
Weight, ounces (grams)	0.21 (6)	2.65 (75)	1.48 (42)	1.48 (42)
Size, inches (L x W x H)	0.50 x 0.91 (D x H)	1.19 x 1.33 x 1.03	0.63 x 1.10 (D x H)	0.63 x 1.10 (D x H)
Connector Type	10-32 axial	2-pin 7/16-27 radial	10-32 radial	10-32 radial
Mounting Method	10-32 tapped hole	Ø.171 thru holes, x3	10-32 tapped hole	10-32 tapped hole
Sensitivity, pC/g (pC/m/s <sup>2</sup> )	15 (1.5)	10 (1)	10 (1)	3.5 (0.35)
Upper Frequency Response, ±5%, Hz	5,000	2,500	5,000	5,000 (±10%)
Maximum Shock Survivability, g (m/s <sup>2</sup> )	3,000 (29,420)	2,000 (19,613)	3,000 (29,420)	5,000 (49,033)
Operating Temperature Range, °F (°C)	-60 to +375 (-51 to +191)	-65 to +600 (-54 to +316)	-65 to +600 (-54 to +316)	-60 to +900 (-51 to +482)
Environmental Seal	hermetic	hermetic	hermetic	hermetic
Electrical Isolation	base	case	no	no
Compatible Cables	6013A, 6019A	6838A, 6845A	6894A, 6946A, 6979A	6894A, 6946A, 6979A
Features	cost effective	differential output	compact size	compact size
Additional Series Variations	-	-	-	-
Similar Series	3056D: IEPE, available in sensitivities from 10 to 500 mV/g	-	-	-



### High Temperature



Model Number	3122C	3152C2	3196C	3197C
Weight, ounces (grams)	0.88 (25)	0.49 (14)	3.00 (85)	3.00 (85)
Size, inches (L x W x H)	0.50 x 0.96 (D x H)	0.50 x 0.97 (D x H)	2.28 x 1.33 x 0.80	2.28 x 1.33 x 0.80
Connector Type	10-32 radial	10-32 axial	TNC radial	TNC radial
Mounting Method	10-32 tapped hole	10-32 tapped hole	Ø.171 thru holes, x3	Ø.171 thru holes, x3
Sensitivity, pC/g (pC/m/s <sup>2</sup> )	50 (5)	4 (0.4)	8 (0.8)	2.4 to 4.5 (0.24 to 0.45)
Upper Frequency Response, ±5%, Hz	5,000 (±8%)	5,000 (±10%)	2,500	2,500
Maximum Shock Survivability, g (m/s <sup>2</sup> )	2,000 (19,613)	3,000 (29,420)	2,000 (19,613)	2,000 (19,613)
Operating Temperature Range, °F (°C)	-60 to +375 (-51 to +191)	-65 to +500 (-54 to +260)	-65 to +500 (-54 to +260)	-65 to +500 (-54 to +260)
Environmental Seal	hermetic	hermetic	hermetic	hermetic
Electrical Isolation	no	no	no	case
Compatible Cables	6013A, 6019A	6013A, 6019A	-	-
Features	compact size	compact size	industry standard tri-bolt mount	industry standard tri-bolt mount
Additional Series Variations	3122C2: 15 pC/g, up to +500°F operating temperature	-	-	-
Similar Series	-	-	-	-

### High Temperature



Model Number	3218C	3220C	3224C	3225E
Weight, ounces (grams)	5.54 (157)	0.14 (4)	0.007 (0.2)	0.02 (0.6)
Size, inches (L x W x H)	1.19 x 1.33 x 0.76	0.67 x 0.41 x 0.25	0.27 x 0.14 x 0.12	0.36 x 0.25 x 0.15
Connector Type	18-inch integral cable to D38999	5-44 radial	3-foot integral cable to 10-32 jack	3-foot integral cable to 10-32 jack
Mounting Method	Ø.171 thru holes, x3	Ø.093 thru hole	adhesive	adhesive
Sensitivity, pC/g (pC/m/s <sup>2</sup> )	1.6 (0.16)	1.5 (0.15)	0.25 to 0.45 (0.025 to 0.045)	1.8 (0.18)
Upper Frequency Response, ±5%, Hz	10,000 (±10%)	5,000	10,000	10,000 (±10%)
Maximum Shock Survivability, g (m/s <sup>2</sup> )	2,000 (19,613)	2,000 (19,613)	1,000 (9,807)	5,000 (49,033)
Operating Temperature Range, °F (°C)	-60 to +900 (-51 to +482)	-60 to +500 (-51 to +260)	-60 to +350 (-51 to +177)	-60 to +350 (-51 to +177)
Environmental Seal	hermetic	hermetic	epoxy	epoxy
Electrical Isolation	case integral hardline cable assembly	base	no	no
Compatible Cables	-	6025A, 6056A	6013A, 6019A	6013A, 6019A
Features	differential output	360° cable orientation low profile	ultra miniature teardrop design	ultra miniature teardrop design
Additional Series Variations	-	3220C1: 10 pC/g	-	3225E1: 3-foot removable cable, hermetic, negative polarity 3225E2: 36-foot removable cable, hermetic, base isolated 3225E3: 3-foot removable cable, hermetic, positive polarity 3225M40: 3-foot integral cable, low outgassing material
Similar Series	-	3220E/M27: IEPE, available in sensitivities of 1 and 10 mV/g	3224A: IEPE, available in sensitivities from 1 to 10 mV/g	3225F: IEPE, available in sensitivities from 1 to 500 mV/g, integral and removable cable options, optional TEDS

## High Temperature



Model Number	3235C1	3255C	3256C	3309A
Weight, ounces (grams)	2.43 (69)	0.35 (10)	0.35 (10)	0.90 (25.5)
Size, inches (L x W x H)	1.66 x 1.19 x 1.03	0.49 x 0.62 (D x H)	0.50 x 0.91 (D x H)	1.26 x 0.80 x 0.50
Connector Type	2-pin 7/16-27 radial	10-32 radial	10-32 axial	3-pin "Mighty Mouse®" radial
Mounting Method	Ø.171 thru holes, x3	10-32 tapped hole	10-32 tapped hole	Ø.171 thru hole
Sensitivity, pC/g (pC/m/s <sup>2</sup> )	50 (5)	15 (1.5)	15 (1.5)	5 (0.5)
Upper Frequency Response, ±5%, Hz	10,000 (±15%)	5,000 (±10)	5,000 (±10%)	5,000
Maximum Shock Survivability, g (m/s <sup>2</sup> )	2,000 (19,613)	3,000 (29,420)	3,000 (29,420)	10,000 (98,067)
Operating Temperature Range, °F (°C)	-60 to +550 (-51 to +287)	-60 to +375 (-51 to +190)	-60 to +375 (-51 to +190)	-60 to +482 (-51 to +250)
Environmental Seal	hermetic	hermetic	hermetic	hermetic
Electrical Isolation	case	no	no	case
Compatible Cables	6838A, 6845A	6013A, 6019A	6013A, 6019A	-
Features	differential output	cost effective	cost effective	360° cable orientation
Additional Series Variations	3235C2: 100 pC/g 3235C3: 200 pC/g	-	-	-
Similar Series	-	3255A: IEPE, available in sensitivities from 10 to 500 mV/g	3256A: IEPE, available in sensitivities from 10 to 500 mV/g	-

## High Temperature



Model Number	3310A	3316M3	3443C
Weight, ounces (grams)	0.06 (1.8)	0.18 (5)	0.35 (10)
Size, inches (L x W x H)	0.40 x 0.35 x 0.24	0.40 x 0.40 x 0.39	0.85 x 0.50 x 0.44
Connector Type	3-foot removable cable to 10-32 jack	10-32 radial	(3) 10-32 radial
Mounting Method	adhesive	10-32 tapped hole	Ø.15 thru holes, x2
Sensitivity, pC/g (pC/m/s <sup>2</sup> )	1.0 to 1.3 (0.10 to 0.13)	1 to 2 (0.1 to 0.2)	2.7 (0.27)
Upper Frequency Response, ±5%, Hz	7,000	10,000 (±10%)	10,000 (±10)
Maximum Shock Survivability, g (m/s <sup>2</sup> )	5,000 (49,033)	10,000 (98,067)	5,000 (49,033)
Operating Temperature Range, °F (°C)	-60 to +500 (-51 to +260)	-60 to +1000 (-51 to +538)	-94 to +500 (-70 to +260)
Environmental Seal	hermetic	hermetic	hermetic
Electrical Isolation	base	no	no
Compatible Cables	6003A03 (supplied), 6013A, 6019A	6894A, 6946A, 6979A, 6999A	6013A, 6019A
Features	ultra miniature teardrop design	ultra high temperature operation miniature, lightweight cubic design	triaxial miniature, lightweight design
Additional Series Variations	-	3316C: 1 to 2 pC/g, 5-40 tapped hole, +900°F, negative polarity 3316C1: 1 to 2 pC/g, 5-40 tapped hole, +900°F 3316M1: 1 to 2 pC/g, 10-32 tapped hole, +900°F 3316M2: 0.5 to 2 pC/g, 5-40 tapped hole, +900°F 3316M5: 1 to 2 pC/g, adhesive mount, integral hardline cable, +1000°F	-
Similar Series	-	-	-



### High Temperature



Model Number	5310M1	5334	5335
Weight, ounces (grams)	0.24 (6.8) accelerometer 1.41 (40) charge amplifier	5.29 (150)	14.11 (400)
Size, inches (L x W x H)	-	1.19 x 1.31 x 0.76	1.20 x 1.30 x 0.76
Connector Type	BNC jack (charge amplifier)	18-inch integral hardline cable to D38999	70-inch integral cable to D38999
Mounting Method	10-32 stud	Ø.171 thru holes, x3	Ø.171 thru holes, x3
Sensitivity, mV/g (mV/m/s <sup>2</sup> )	10 (1)	10 (1)	10 (1)
Full Scale Range, g (m/s <sup>2</sup> )	500 (4,903)	500 (4,903)	500 (4,903)
Frequency Response, ±5%, Hz	10 to 10,000	4.8 to 660	4.8 to 1,400
Maximum Shock Survivability, g (m/s <sup>2</sup> )	3,000 (29,420)	2,000 (19,613)	2,000 (19,613)
Operating Temperature Range, °F (°C)	-100 to +500 (-73 to +260)	-65 to +900 (-54 to +482)	-65 to +900 (-54 to +482)
Environmental Seal	hermetic	hermetic	hermetic
Electrical Isolation	no	case	case
Compatible Cables	6019B10 (supplied)	6988A	6888A4.5 (supplied)
Features	system includes model 3030C1 accelerometer, model 6019B10 low noise cable, model 4705M13 charge amplifier	integrated differential amplifier uniquely combines IEPE and charge output technology, seamlessly operating as a single unit	integrated differential amplifier uniquely combines IEPE and charge output technology, seamlessly operating as a single unit
Additional Series Variations	-	-	-
Similar Series	5310M2: 5 mV/g, 1,000g range	-	-

### Industrial



Model Number	3019A	3059A	3063B	3148E
Weight, ounces (grams)	0.28 (8)	2.61 (74)	8.64 (245)	1.69 (48)
Size, inches (L x W x H)	0.38 x 0.73 (D x H)	1.73 x 0.74 x 0.85	1.63 x 1.63 x 0.95	0.62 x 1.44 (D x H)
Connector Type	10-32 axial	2-pin MIL-C-5015 radial	4-pin bayonet-style radial	BNC radial
Mounting Method	1/4-28 stud	1/4-28 thru hole	1/4-28 thru hole	10-32 tapped hole
Sensitivity, mV/g (mV/m/s <sup>2</sup> )	10 (1)	100 (10)	100 (10)	100 (10)
Full Scale Range, g (m/s <sup>2</sup> )	500 (4,903)	50 (490)	50 (490)	50 (490)
Frequency Response, ±5%, Hz	1 to 10,000	0.3 to 8,000 (±3dB)	0.5 to 3,000	0.5 to 5,000
Maximum Shock Survivability, g (m/s <sup>2</sup> )	3,000 (29,420)	3,000 (29,420)	2,000 (19,613)	3,000 (29,420)
Operating Temperature Range, °F (°C)	-60 to +300 (-51 to +149)	-60 to +250 (-51 to +121)	-65 to +250 (-54 to +121)	-60 to +250 (-51 to +121)
Environmental Seal	hermetic	hermetic	hermetic	epoxy
Electrical Isolation	base	case	case	base
Compatible Cables	6010A, 6011A	6038A, 6080A, 6082A, 6406A, 6407A, 6459A	6428A, 6458A	6020A
Features	excellent high frequency response	low noise JFET electronics	triaxial available with water and oil resistant environmental boot	rugged design
Additional Series Variations	3019A1: 10 mV/g, 500g range, 10-32 stud mount	-	-	-
Similar Series	-	-	-	-

Industrial



Model Number	3166B	3176B	3184E	3185D
Weight, ounces (grams)	8.04 (228)	1.55 (44)	3.77 (107)	1.94 (55)
Size, inches (L x W x H)	2.90 x 1.00 x 1.21	0.69 x 1.68 (D x H)	1.00 x 2.06 (D x H)	0.75 x 1.72 (D x H)
Connector Type	2-pin MIL-C-5015 radial	2-pin MIL-C-5015 axial	2-pin MIL-C-5015 axial	TNC axial
Mounting Method	1/4-28 thru hole	10-32 tapped hole	1/4-28 tapped hole	1/4-28 tapped hole
Sensitivity, mV/g (mV/m/s <sup>2</sup> )	100 (10)	100 (10)	100 (10)	100 (10)
Full Scale Range, g (m/s <sup>2</sup> )	50 (490)	50 (490)	50 (490)	50 (490)
Frequency Response, ±5%, Hz	0.5 to 5,000	0.3 to 10,000 (±10%)	0.4 to 5,000	2 to 10,000 (±10%)
Maximum Shock Survivability, g (m/s <sup>2</sup> )	3,000 (29,420)	5,000 (49,033)	3,000 (29,420)	3,000 (29,420)
Operating Temperature Range, °F (°C)	-60 to +250 (-51 to +121)	-60 to +250 (-51 to +121)	-60 to +250 (-51 to +121)	-60 to +250 (-51 to +121)
Environmental Seal	hermetic	hermetic	hermetic	hermetic
Electrical Isolation	case	case	case	base
Compatible Cables	6038A, 6080A, 6082A, 6406A, 6407A, 6459A	6038A, 6080A, 6082A, 6406A, 6407A, 6459A	6038A, 6080A, 6082A, 6406A, 6407A, 6459A	6086A, 6087A, 6090A, 6091A, 6404A, 6405A, 6410A
Features	360° cable orientation available with water and oil resistant environmental boot	cost effective	available with water and oil resistant environmental boot	available with water and oil resistant environmental boot
Additional Series Variations	3166B1: 500 mV/g, 10g range 3166B2: 10 mV/g, 500g range	3176B1: 100 mV/g, 50g range, 1/4-28 tapped hole	-	-
Similar Series	-	-	-	-

Industrial



Model Number	3187D	3191A	3192A	3202A
Weight, ounces (grams)	4.30 (122)	27.34 (775)	6.70 (190)	5.64 (160)
Size, inches (L x W x H)	1.00 x 2.06 (D x H)	1.69 x 3.64 (D x H)	1.27 x 2.25 (D x H)	2.31 x 1.37 x 1.13
Connector Type	2-pin MIL-C-5015 axial	2-pin MIL-C-5015 axial	2-pin MIL-C-5015 axial	2-pin MIL-C-5015 radial
Mounting Method	1/4-28 tapped hole	1/4-28 tapped hole	1/4-28 tapped hole	1/4-28 thru hole
Sensitivity, mV/g (mV/m/s <sup>2</sup> )	500 (50)	5,000 (500)	1,000 (100)	100 (10)
Full Scale Range, g (m/s <sup>2</sup> )	10 (98)	1 (10)	5 (49)	50 (490)
Frequency Response, ±5%, Hz	0.48 to 1,000	0.08 to 1,000	0.5 to 1,000	0.5 to 5,000
Maximum Shock Survivability, g (m/s <sup>2</sup> )	3,000 (29,420)	100 (981)	100 (981)	3,000 (29,420)
Operating Temperature Range, °F (°C)	-60 to +250 (-51 to +121)	-60 to +225 (-51 to +107)	-60 to +250 (-51 to +121)	-60 to +250 (-51 to +121)
Environmental Seal	hermetic	hermetic	hermetic	hermetic
Electrical Isolation	case	case	case	case
Compatible Cables	6038A, 6080A, 6082A, 6406A, 6407A, 6459A	6038A, 6080A, 6082A, 6406A, 6407A, 6459A	6038A, 6080A, 6082A, 6406A, 6407A, 6459A	6038A, 6080A, 6082A, 6406A, 6407A, 6459A
Features	available with water and oil resistant environmental boot	ultra high sensitivity available with water and oil resistant environmental boot	ultra high sensitivity	360° cable orientation available with water and oil resistant environmental boot
Additional Series Variations	-	3191A1: 10,000 mV/g, 0.5g range	-	3202A1: 500 mV/g, 10g range 3202A2: 100 mV/g, 50g range, compatible with Immersion Proof boot 3202A3: 500 mV/g, 10g range, compatible with Immersion Proof boot
Similar Series	-	-	-	-



### Industrial



Model Number	3213D1
Weight, ounces (grams)	2.29 (65)
Size, inches (L x W x H)	1.25 x 1.25 x 0.75
Connector Type	4-pin M12 radial
Mounting Method	10-32 thru hole
Sensitivity, mV/g (mV/m/s <sup>2</sup> )	100 (10)
Full Scale Range, g (m/s <sup>2</sup> )	50 (490)
Frequency Response, ±5%, Hz	Axis 1 & 2: 2 to 7,000 Axis 3: 2 to 10,000 (±3dB)
Maximum Shock Survivability, g (m/s <sup>2</sup> )	5,000 (49,033)
Operating Temperature Range, °F (°C)	-60 to +250 (-51 to +121)
Environmental Seal	hermetic
Electrical Isolation	case
Compatible Cables	6919A
Features	triaxial 360° cable orientation
Additional Series Variations	-
Similar Series	3213M6: 100 mV/g, 50g range, 4-pin Brad Harrison™ radial connector

### Magnets



Rare earth magnets provide unsurpassed pull strength. Two pole configurations assure a steady grip on curved surfaces. Flat magnets are for use on flat surfaces for high frequency response. Use caution when applying to ferromagnetic surfaces as excessive metal to metal shock can damage unprotected accelerometers.

- 6187 2-Pole, 1.5" dia. x 1.5" tall, 1/4-28 mtg. hole
- 6190 2-Pole, 1.25" dia. x .90 tall, 1/4-28 mtg. hole
- 6196 Flat, 3/4" hex x .250 thick, 10-32 mtg. stud
- 6537 Flat, 7/8" hex x .190 thick, 10-32 mtg. stud
- 6540 Flat, .950 dia. x .420 thick, 1/4-28 mfg. stud

### Adhesive Pads



Mounting pads assure that data is taken at the same location each time on a properly prepared surface. Pads should be used whenever drilling and tapping a mounting hole in the monitoring target is prohibited.

- 6186 Adhesive pad, 1/4-28 integral thread, 7/8" hex, for 3184D, 3185B, 3187D
- 6213 Adhesive pad, 10-32 integral thread, 5/8" hex, for 3148D
- 6294 Adhesive pad, 1/4-28 tapped hole, for 3166A, A1, 3063A
- 6286 Adhesive mounting plate for magnets, provides flat surface, repeatable data

### Miniature/ESS



Model Number	3030B5	3032A	3035B	3089A
Weight, ounces (grams)	0.24 (6.8)	0.05 (1.5)	0.09 (2.5)	0.02 (0.6)
Size, inches (L x W x H)	0.41 x 0.67 (D x H)	0.25 x 0.28 (D x H)	0.50 x 0.28 x 0.33	0.19 x 0.25 (D x H)
Connector Type	10-32 axial	18-inch integral cable to 10-32 jack	5-44 radial	4-foot integral wires
Mounting Method	10-32 stud	adhesive	5-40 stud	adhesive
Sensitivity, mV/g (mV/m/s <sup>2</sup> )	10 (1)	10 (1)	100 (10)	10 (1)
Full Scale Range, g (m/s <sup>2</sup> )	500 (4,903)	500 (4,903)	50 (490)	500 (4,903)
Frequency Response, ±5%, Hz	5 to 10,000	1 to 10,000 (±10%)	0.5 to 10,000 (±10%)	1 to 10,000 (±10%)
Maximum Shock Survivability, g (m/s <sup>2</sup> )	3,000 (29,420)	1,500 (14,710)	3,000 (29,420)	3,000 (29,420)
Operating Temperature Range, °F (°C)	-148 to +250 (-100 to +121)	-60 to +250 (51 to +121)	-60 to +225 (-51 to +107)	-60 to +250 (-51 to +121)
Environmental Seal	hermetic	epoxy	hermetic	hermetic
Electrical Isolation	no	no	no	no
Compatible Cables	6010A, 6011A	6010A, 6011A	6014A, 6029A, 6040A	-
Features	ESS industry standard extended low frequency response high temperature option available	low profile	miniature	cost effective OEM/embedded applications
Additional Series Variations	3030B4: 10 mV/g, 500g range, 2 to 10,000 Hz frequency range 3030B5H: 10 mV/g, 500g range, +325°F operation	3032A1: 5 mV/g, 1,000g range 3032M9: 10 mV/g, 500g range, 10-foot integral cable	3035B1: 10 mV/g, 500g range 3035B2: 50 mV/g, 100g range	-
Similar Series	3030BG: 10 mV/g, 500g range, adhesive mount 3030C1: charge mode, 0.4 pC/g sensitivity	-	3035M18: M3 stud mount, 10 mV/g, 500g range 3035BG: adhesive mount, available in sensitivities from 10 to 100 mV/g 3035C: charge mode, 2.5 pC/g 3035CG: charge mode, 2.5 pC/g, adhesive mount	-

## Miniature/ESS



Model Number	3097A1	3145A	3220E	3224A1
Weight, ounces (grams)	0.15 (4.3)	0.08 (2.3)	0.10 (2.7)	0.007 (0.2)
Size, inches (L x W x H)	0.40 x 0.40 x 0.41	0.24 x 0.49 (D x H)	0.67 x 0.41 x 0.25	0.20 x 0.14 x 0.12
Connector Type	10-32 radial	5-44 axial	5-44 radial	3-foot integral cable to 10-32 jack
Mounting Method	5-40 tapped hole	5-40 stud	Ø.093 thru hole	adhesive
Sensitivity, mV/g (mV/m/s <sup>2</sup> )	10 (1)	100 (10)	10 (1)	9 to 14 (0.9 to 0.14)
Full Scale Range, g (m/s <sup>2</sup> )	500 (4,903)	50 (490)	500 (4,903)	500 (4,903)
Frequency Response, ±5%, Hz	0.3 to 5,000	0.8 to 10,000 (±10%)	1 to 5,000	0.3 to 20,000 (±10%)
Maximum Shock Survivability, g (m/s <sup>2</sup> )	5,000 (49,033)	3,000 (29,420)	2,000 (19,613)	3,000 (29,420)
Operating Temperature Range, °F (°C)	-60 to +200 (-51 to +93)	-60 to +185 (-51 to +85)	-60 to +250 (-51 to +121)	-60 to +300 (-51 to +149)
Environmental Seal	hermetic	hermetic	hermetic	epoxy
Electrical Isolation	no	no	base	no
Compatible Cables	6010A, 6011A	6014A, 6029A, 6040A	6014A, 6029A, 6040A	6010A, 6011A
Features	miniature cubic design low noise JFET electronics	miniature design	360° cable orientation	ultra miniature teardrop design
Additional Series Variations	3097A2: 100 mV/g, 50g range 3097A3: 500 mV/g, 10g range	3145A1: 10 mV/g, 500g range 3145A2: 5 mV/g, 1,000g range	3220M27: 1 mV/g, 5,000g range	3224A2: 2 mV/g, 2,500g range 3224A3: 5 mV/g, 1,000g range 3224A4: 1 mV/g, 5,000g range
Similar Series	3097AT: TEDS	3145AG: adhesive mount, available in sensitivities from 5 to 100 mV/g	3220C: charge mode, available in sensitivities of 1.5 and 10 pC/g	3224B: case isolated, 10 mV/g, 500g range 3224C: charge mode, 0.6 pC/g

## Miniature/ESS

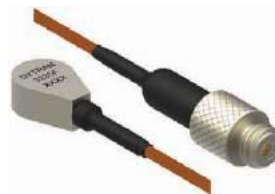

Model Number	3225F	
Weight, ounces (grams)	0.02 (0.6)	
Size, inches (L x W x H)	0.36 x 0.25 x 0.15	
Connector Type	3-foot integral cable to 10-32 jack	
Mounting Method	adhesive	
Sensitivity, mV/g (mV/m/s <sup>2</sup> )	10 (1)	
Full Scale Range, g (m/s <sup>2</sup> )	500 (4,903)	
Frequency Response, ±5%, Hz	1.6 to 10,000 (±10%)	
Maximum Shock Survivability, g (m/s <sup>2</sup> )	5,000 (49,033)	
Operating Temperature Range, °F (°C)	-60 to +250 (-51 to +121)	
Environmental Seal	epoxy	
Electrical Isolation	no	
Compatible Cables	6010A, 6011A	
Features	ultra miniature teardrop design	
Additional Series Variations	3225F1: 10 mV/g, 500g range, 3-foot removable cable, hermetic 3225F2: 10 mV/g, 500g range, 3-foot removable cable, hermetic, base isolated 3225F3: 10 mV/g, 500g range, 3-foot integral cable, epoxy, based isolated 3225F4T: 1 mV/g, 5,000g range, 3-foot removable cable, hermetic, TEDS 3225F5T: 10 mV/g, 500g range, 17-foot removable cable, hermetic, TEDS 3225M5: 1 mV/g, 5,000g range, 3-foot removable cable, hermetic	3225M7: 1 mV/g, 5,000g range, 10-foot removable cable, hermetic 3225M23: 50 mV/g, 100g range, 3-foot removable cable, hermetic 3225M24: 100 mV/g, 50g range, 3-foot removable cable, hermetic 3225M36: 10 mV/g, 500g range, 20-foot removable cable, epoxy, TEDS 3225M37: 5 mV/g, 1,000g range, 20-foot removable cable, epoxy, TEDS 3225M39 10 mV/g, 500g range, 3-foot integral cable, hermetic, low-end frequency response of 1.2 Hz
Similar Series	3225E: charge mode, 1.8 pC/g, available with removable and integral cable options	



### Miniature/ESS



Model Number	3274A1	3305A1	3311A
Weight, ounces (grams)	0.07 (2)	0.13 (3.7)	0.12 (3.3)
Size, inches (L x W x H)	0.35 x 0.31 x 0.24	0.40 x 0.40 x 0.32	0.70 x 0.41 x 0.27
Connector Type	3-foot removable cable to 10-32 jack	10-32 radial	5-44 radial
Mounting Method	adhesive	adhesive	Ø.093 thru hole
Sensitivity, mV/g (mV/m/s <sup>2</sup> )	5 (0.5)	10 (1)	50 (5)
Full Scale Range, g (m/s <sup>2</sup> )	1,000 (9,807)	500 (4,903)	100 (981)
Frequency Response, ±5%, Hz	1.1 to 10,000 (±10%)	0.3 to 5,000	2 to 10,000 (±10%)
Maximum Shock Survivability, g (m/s <sup>2</sup> )	5,000 (49,033)	5,000 (49,033)	3,000 (29,420)
Operating Temperature Range, °F (°C)	-60 to +250 (-51 to +121)	-60 to +200 (-51 to +93)	-60 to +320 (-51 to +160)
Environmental Seal	hermetic	hermetic	hermetic
Electrical Isolation	case	no	base
Compatible Cables	6010A, 6011A	6010A, 6011A	6014A, 6029A, 6040A
Features	ultra miniature teardrop design TEDS	miniature cubic design low noise JFET electronics	360° cable orientation high temperature operation
Additional Series Variations	3274A2: 10 mV/g, 500g range 3274A3: 25 mV/g, 200g range	3305A2: 100 mV/g, 50g range 3305A3: 500 mV/g, 10g range	-
Similar Series	-	-	-

### Shock



Model Number	3086A1	3200B
Weight, ounces (grams)	0.12 (3.5)	0.21 (6)
Size, inches (L x W x H)	0.38 x 0.51 (D x H)	0.41 X 0.64 (D x H)
Connector Type	solder pins axial	10-32 axial
Mounting Method	1/4-28 stud	1/4-28 stud
Sensitivity, mV/g (mV/m/s <sup>2</sup> )	0.05 (0.005)	0.05 (0.005)
Full Scale Range, g (m/s <sup>2</sup> )	70,000 (686,466)	70,000 (686,466)
Frequency Response, ±5%, Hz	0.35 to 10,000 (±10%)	0.35 to 10,000 (±10%)
Maximum Shock Survivability, g (m/s <sup>2</sup> )	100,000 (980,655)	100,000 (980,655)
Operating Temperature Range, °F (°C)	-60 to +250 (-51 to +121)	-60 to +250 (-51 to +121)
Environmental Seal	hermetic	epoxy
Electrical Isolation	base	base
Compatible Cables	6869A	6010A, 6011A
Features	high natural frequency of 100 kHz	high natural frequency of >100 kHz
Additional Series Variations	3086A2: 0.1 mV/g, 50,000g range 3086A3: 0.25 mV/g, 20,000g range 3086A4: 0.5 mV/g, 10,000g range 3086A5: 1.0 mV/g, 5,000g range 3086A6: 2.0 mV/g, 2,500g range	3200B2: 0.1 mV/g, 50,000g range 3200B3: 0.25 mV/g, 20,000g range 3200B4: 0.5 mV/g, 10,000g range 3200B5: 1.0 mV/g, 5,000g range 3200B6: 2.0 mV/g, 2,500g range
Similar Series	3086AT: 10-32 stud mount, available with sensitivities from 0.05 to 2.0 mV/g	3200BM: M6 stud mount, available with sensitivities from 0.05 to 2.0 mV/g 3200BT: 10-32 stud mount, available with sensitivities from 0.05 to 2.0 mV/g

## Triaxial



Model Number	3023A	3023A1	3023A2
Weight, ounces (grams)	0.11 (3)	0.14 (4)	0.14 (4)
Size, inches (L x W x H)	0.36 x 0.36 x 0.36	0.36 x 0.36 x 0.49	0.35 x 0.35 x 0.49
Connector Type	1/4-28 4-pin radial	1/4-28 4-pin radial	1/4-28 4-pin radial
Mounting Method	adhesive	5-40 tapped hole	10-32 tapped hole
Sensitivity, mV/g (mV/m/s <sup>2</sup> )	10 (1)	10 (1)	10 (1)
Full Scale Range, g (m/s <sup>2</sup> )	500 (4,903)	500 (4,903)	500 (4,903)
Frequency Response, ±5%, Hz	1.5 to 4,000	1.5 to 4,000	1.5 to 4,000
Maximum Shock Survivability, g (m/s <sup>2</sup> )	5,000 (49,033)	5,000 (49,033)	5,000 (49,033)
Operating Temperature Range, °F (°C)	-60 to +250 (-51 to +121)	-60 to +250 (-51 to +121)	-60 to +250 (-51 to +121)
Environmental Seal	hermetic	hermetic	hermetic
Electrical Isolation	no	no	no
Compatible Cables	6811A, 6824A	6811A, 6824A	6811A, 6824A
Features	miniature triaxial design	miniature triaxial design	miniature triaxial design
Additional Series Variations	3023AH: 10 mV/g, 500g range, +325°F 3023A3: 5 mV/g, 1,000g range 3023A3H: 5 mV/g, 1,000g range, +325°F 3023A4H: 1 mV/g, 5,000g range, +325°F 3023A5: 1 mV/g, 5,000g range 3023M27: 10 mV/g, 500g range, XYZ marking 3023M30: 10 mV/g, 500g range, XYZ marking, +325°F	3023A4: 5 mV/g, 1,000g range	3023A2H: 10 mV/g, 500g range, +320°F 3023A6: 5 mV/g, 1,000g range 3023A6H: 5 mV/g, 1,000g range, +320°F 3023A9: 1 mV/g, 5,000g range 3023M23: 10 mV/g, 500g range, XYZ marking, +325°F
Similar Series	3023AT: 10 mV/g, 500g range, TEDS	3023A1T: 10 mV/g, 500g range, TEDS	-

## Triaxial



Model Number	3033B2	3053B	3093M17	3093M22
Weight, ounces (grams)	0.39 (11)	0.21 (6)	0.48 (13.5)	0.49 (13)
Size, inches (L x W x H)	0.60 x 0.60 x 0.31	0.50 x 0.50 x 0.35	0.96 x 0.58 x 0.54	0.59 x 0.59 x 0.60
Connector Type	44-inch integral cable to (3) BNC plugs	1/4-28 4-pin Dytran radial	1/4-28 4-pin radial	1/4-28 4-pin radial
Mounting Method	4-40 thru hole	adhesive	10-32 tapped hole	adhesive
Sensitivity, mV/g (mV/m/s <sup>2</sup> )	10 (1)	10 (1)	100 (10)	5 (0.5)
Full Scale Range, g (m/s <sup>2</sup> )	500 (4,903)	500 (4,903)	50 (490)	1,000 (9,807)
Frequency Response, ±5%, Hz	1 to 8,000	2 to 5,000 (±10%)	0.6 to 5,000	3.3 to 3,000
Maximum Shock Survivability, g (m/s <sup>2</sup> )	1,000 (9,807)	5,000 (49,033)	7,000 (68,647)	5,000 (49,033)
Operating Temperature Range, °F (°C)	-60 to +250 (-51 to +121)	-60 to +250 (-51 to +121)	-60 to +225 (-51 to +107)	-60 to +250 (-51 to +121)
Environmental Seal	epoxy	hermetic	hermetic	hermetic
Electrical Isolation	no	case	case	case
Compatible Cables	-	6430A, 6431A, 6801A, 6830A	6811A, 6824A	6811A, 6824A
Features	360° cable orientation	lightweight	isolated design	isolated design
Additional Series Variations	-	3053B1: 5 mV/g, 1,000g range	3093M27: 10 mV/g, 500g range, +320°F	-
Similar Series	-	3053B2: 10 mV/g, 500g range, 10-32 tapped hole 3053M10: 10 mV/g, 500g range, 10-32 tapped hole, XYZ marking	3093M8: 100 mV/g, 50g range, TEDS 3093M18: 10 mV/g, 500g range, TEDS 3093M28: 5 mV/g, 1,000g range, 1,2,3 marking TEDS	-



### Triaxial



Model Number	3133A1	3143D	3233A	3263A1
Weight, ounces (grams)	0.03 (0.8)	0.49 (14)	1.06 (30)	0.20 (5.6)
Size, inches (L x W x H)	0.24 x 0.24 x 0.24	0.82 x 0.82 x 0.34	1.00 x 1.00 x 0.52	0.48 x 0.48 x 0.44
Connector Type	3-foot integral cable to 1/4-28 4-pin	1/4-28 4-pin radial	1/4-28 4-pin radial	1/4-28 4-pin radial
Mounting Method	adhesive	6-32 thru hole	8-32 thru hole	4-40 tapped hole
Sensitivity, mV/g (mV/m/s <sup>2</sup> )	10 (1)	10 (1)	1,000 (100)	10 (1)
Full Scale Range, g (m/s <sup>2</sup> )	500 (4,903)	500 (4,903)	5 (49)	500 (4,903)
Frequency Response, ±5%, Hz	0.25 to 10,000 (±10%)	0.5 to 3,000	Axis 1 & 2: 0.3 to 3,000 Axis 3: 0.3 to 6,000 (±10%)	0.3 to 10,000 (+15/-10%)
Maximum Shock Survivability, g (m/s <sup>2</sup> )	3,000 (29,420)	1,500 (14,710)	5,000 (49,033)	5,000 (49,033)
Operating Temperature Range, °F (°C)	-60 to +250 (-51 to +121)	-60 to +185 (-51 to +85)	-60 to +200 (-51 to +93)	-60 to +250 (-51 to +121)
Environmental Seal	epoxy	hermetic	hermetic	hermetic
Electrical Isolation	no	case	base	no
Compatible Cables	6811A	6811A, 6824A	6811A, 6824A	6811A, 6824A
Features	ultra miniature	360° cable orientation	360° cable orientation ultra high sensitivity	lightweight low noise
Additional Series Variations	3133A2: 2 mV/g, 2,500g range 3133A3: 5 mV/g, 1,000g range 3133A4: 1 mV/g, 5,000g range	3143D1: 100 mV/g, 50g range 3143D2: 50 mV/g, 100g range	-	3263A2: 100 mV/g, 50g range 3263A3: 50 mV/g, 100g range
Similar Series	3133B: case isolated, available in sensitivities from 2 to 10 mV/g	3143DT: TEDS 3143M16: cryogenic, 10 mV/g, 500g range, -320°F operation	3233AT: TEDS	3263AT: TEDS 3263A7T/A8T: M3 tapped hole, available with sensitivities of 10 and 100 mV/g, TEDS

### Triaxial



Model Number	3273A1	3293A	3313A1	3333A1
Weight, ounces (grams)	0.10 (2.7)	0.31 (8.8)	0.14 (4.1)	0.08 (2.3)
Size, inches (L x W x H)	0.36 x 0.36 x 0.35	0.55 x 0.55 x 0.37	0.36 x 0.36 x 0.47	0.36 x 0.36 x 0.32
Connector Type	1/4-28 4-pin radial	1/4-28 4-pin radial	1/4-28 4-pin radial	M4.5 x 0.35 4-pin radial
Mounting Method	adhesive	5-40 tapped hole	10-32 tapped hole	adhesive
Sensitivity, mV/g (mV/m/s <sup>2</sup> )	10 (1)	500 (50)	1 (0.1)	10 (1)
Full Scale Range, g (m/s <sup>2</sup> )	500 (4,903)	7 (69)	5,000 (49,030)	500 (4,903)
Frequency Response, ±5%, Hz	0.5 to 3,000	0.25 to 4,000 (±10%)	1.2 to 10,000 (±15%)	0.31 to 10,000 (+15/-10%)
Maximum Shock Survivability, g (m/s <sup>2</sup> )	5,000 (49,033)	1,000 (9,807)	5,000 (49,033)	5,000 (49,033)
Operating Temperature Range, °F (°C)	-60 to +225 (-51 to +107)	-60 to +185 (-51 to +85)	-60 to +250 (-51 to +121)	-60 to +225 (-51 to +107)
Environmental Seal	hermetic	hermetic	hermetic	hermetic
Electrical Isolation	no	no	no	no
Compatible Cables	6811A, 6824A	6811A, 6824A	6811A, 6824A	6893A, 6895A, 6948A, 6949A, 6975A
Features	low noise JFET electronics lightweight design	high sensitivity low noise	miniature design broad frequency response	miniature 4-pin connector extended low frequency response
Additional Series Variations	3273A2: 100 mV/g, 50g range 3273A4: 50 mV/g, 100g range	-	3313A2: 5 mV/g, 1,000g range 3313A3: 10 mV/g, 500g range	3333A2: 100 mV/g, 50g range 3333A3: 50 mV/g, 100g range
Similar Series	3273AT: TEDS 3273M2: 10-32 tapped hole, 100 mV/g, 50g range	-	3313AH: +325°F operation, available in sensitivities from 1 to 10 mV/g	3333AT: TEDS, available in sensitivities from 1 to 100 mV/g 3333M1T/M2T/M3T/M5: TEDS, case isolated, available in sensitivities from 5 to 100 mV/g 3333M4T/M5T/M6T: TEDS, case isolated, 1/4-28 4-pin radial connector, available in sensitivities from 1 to 25 mV/g

## Triaxial



Model Number	3343A	3403A	3413A1	3533A
Weight, ounces (grams)	0.08 (2.4)	0.14 (4)	0.46 (13)	0.88 (25)
Size, inches (L x W x H)	0.36 x 0.36 x 0.29	0.43 x 0.43 x 0.32	0.59 x 0.59 x 0.60	0.59 x 0.59 x 0.68
Connector Type	M4.5 x 0.35 4-pin radial	M4.5 x 0.35 4-pin radial	1/4-28 4-pin radial	3/8-28 4-pin "Mighty Mouse®" radial
Mounting Method	adhesive	adhesive	adhesive	10-32 tapped hole
Sensitivity, mV/g (mV/m/s <sup>2</sup> )	10 (1)	10 (1)	5 (0.5)	5 (0.5)
Full Scale Range, g (m/s <sup>2</sup> )	500 (4,903)	500 (4,903)	1,000 (9,807)	1,000 (9,807)
Frequency Response, ±5%, Hz	1.2 to 5,000 (+15/-10%)	1.2 to 5,000 (+15/-5%)	3.3 to 3,000	3.3 to 1,000
Maximum Shock Survivability, g (m/s <sup>2</sup> )	5,000 (49,033)	5,000 (49,033)	5,000 (49,033)	5,000 (49,033)
Operating Temperature Range, °F (°C)	-60 to +250 (-51 to +121)	-60 to +250 (-51 to +121)	-60 to +256 (-51 to +124)	-60 to +250 (-51 to +121)
Environmental Seal	hermetic	hermetic	hermetic	hermetic
Electrical Isolation	no	case	case	case
Compatible Cables	6893A, 6895A, 6948A, 6949A, 6975A	6893A, 6895A, 6948A, 6949A, 6975A	6811A, 6824A	6669A
Features	miniature 4-pin connector	miniature 4-pin connector isolated design	TEDS isolated design	TEDS isolated design
Additional Series Variations	3343A2: 2 mV/g, 2,500g range 3343A3: 5 mV/g, 1,000g range	-	3413A2: 50 mV/g, 100g range	-
Similar Series	-	-	-	-

## Specialty



Model Number	3003B	3006A	3010M14	3045A
Weight, ounces (grams)	0.21 (6)	0.42 (12)	0.74 (21)	0.71 (20)
Size, inches (L x W x H)	0.54 x 0.54 x 0.37	0.49 x 0.54 x 0.80	0.49 x 1.15 (D x H)	0.63 x 1.13 (D x H)
Connector Type	22-inch integral wires	10-foot integral cable to flying leads	10-32 axial	10-32 axial
Mounting Method	adhesive	10-32 tapped hole	10-32 tapped hole	1/4-28 stud
Sensitivity, mV/g (mV/m/s <sup>2</sup> )	2 (0.2)	100 (10)	10 (1)	5 (0.5)
Full Scale Range, g (m/s <sup>2</sup> )	500 (4,903)	50 (490)	500 (4,903)	1,000 (9,807)
Frequency Response, ±5%, Hz	2 to 5,000 (±10%)	0.32 to 5,000	1 to 5,000	1.6 to 2,500 (±3dB)
Maximum Shock Survivability, g (m/s <sup>2</sup> )	5,000 (49,033)	3,000 (29,420)	3,000 (29,420)	2,000 (19,613)
Operating Temperature Range, °F (°C)	-40 to +347 (-40 to +175)	-60 to +250 (-51 to +121)	-60 to +250 (-51 to +121)	-320 to +300 (-320 to +149)
Environmental Seal	hermetic	hermetic	hermetic	hermetic
Electrical Isolation	no	case	no	case
Compatible Cables	-	-	6010A, 6011A	-
Features	Triaxial low bias voltage	moisture resistant splash proof boot	back-to-back calibration accelerometer	cryogenic
Additional Series Variations	-	-	-	-
Similar Series	-	-	-	-



### Specialty



Model Number	3120B	3123A	3128A	3143M16
Weight, ounces (grams)	3.00 (85)	3.53 (100)	1.76 (50)	1.76 (50)
Size, inches (L x W x H)	0.83 x 1.07 (D x H)	0.70 x 1.47 (D x H)	0.63 x 1.16 (D x H)	0.81 x 0.81 x 0.60
Connector Type	10-32 radial	10-32 radial	10-32 radial	3/8-28 "Mighty Mouse®" 4-pin radial
Mounting Method	10-32 tapped hole	10-32 tapped hole	10-32 tapped hole	6-32 thru hole
Sensitivity, mV/g (mV/m/s <sup>2</sup> )	10.5 (1.05)	100 (10)	1,000 (100)	10 (1)
Full Scale Range, g (m/s <sup>2</sup> )	500 (4,903)	50 (490)	1.5 (14.7)	500 (4,903)
Frequency Response, ±5%, Hz	10 to 10,000 (±2%)	10 to 5,000 (±2%)	0.25 to 3,000	1.6 to 5,000
Maximum Shock Survivability, g (m/s <sup>2</sup> )	2,000 (19,613)	3,000 (29,420)	100 (981)	3,000 (29,420)
Operating Temperature Range, °F (°C)	-60 to +200 (-51 to +93)	-60 to +200 (-51 to +93)	-60 to +200 (-51 to +93)	-320 to +250 (-196 to +121)
Environmental Seal	hermetic	epoxy	hermetic	hermetic
Electrical Isolation	no	no	case	case
Compatible Cables	6011A	6011A	-	-
Features	calibration standard accelerometer	calibration standard accelerometer	low bias voltage	triaxial cryogenic
Additional Series Variations	-	-	-	-
Similar Series	-	-	-	3243D: -60° to +250° F operation, available in sensitivities from 10 to 100 mV/g

### Specialty



Model Number	3205B	3211M1	3217A	3243A
Weight, ounces (grams)	0.09 (2.5)	0.34 (9.6)	0.18 (5)	0.09 (2.5)
Size, inches (L x W x H)	0.30 x 0.28 (D x H)	0.60 x 0.42 (D x H)	0.50 x 0.50 x 0.50	0.36 x 0.36 x 0.28
Connector Type	35-inch integral wires	10-foot integral cable to BNC plug	10-foot integral cable to BNC plug	78-inch integral cable to flying leads
Mounting Method	adhesive	Ø.171 thru hole	adhesive mount	adhesive mount
Sensitivity, mV/g (mV/m/s <sup>2</sup> )	2 (0.2)	10 (1)	100 (10)	10 (1)
Full Scale Range, g (m/s <sup>2</sup> )	500 (4,903)	500 (4,903)	50 (490)	500 (4,903)
Frequency Response, ±5%, Hz	0.64 to 5,000 (±3dB)	1 to 10,000	1 to 10,000 (±10%)	2 to 7,000 (+15/-5%)
Maximum Shock Survivability, g (m/s <sup>2</sup> )	5,000 (49,033)	5,000 (49,033)	5,000 (49,033)	5,000 (49,033)
Operating Temperature Range, °F (°C)	-40 to +347 (-40 to +175)	-67 to +250 (-55 to +121)	-60 to +250 (-51 to +121)	-60 to +250 (-51 to +121)
Environmental Seal	epoxy	hermetic	hermetic	hermetic
Electrical Isolation	no	base	base	case
Compatible Cables	-	-	-	-
Features	low bias voltage	submersible to 175 psi 360° cable orientation	submersible to 175 psi high natural frequency	submersible triaxial lightweight, low profile design
Additional Series Variations	3205M1: 0.33 mV/g, 3,000g range	-	-	3243M2: 79-inch cable to (3) BNC plugs, 10 mV/g, 500g range
Similar Series	-	3211A: non-submersible, 10-32 radial connector, available in sensitivities of 10 and 100 mV/g	-	-

## Specialty



Model Number	3306A1	3334A1	5313A	7705A1
Weight, ounces (grams)	1.31 (37)	0.07 (2)	8.00 (227)	0.53 (15)
Size, inches (L x W x H)	0.73 x 1.43 (D x H)	0.50 x 0.28 x 0.33	9.16 x 0.47 (D x H)	0.62 x 0.73 (D x H)
Connector Type	3-pin bayonet-style axial	5-44 radial	10-foot integral cable to (3) BNC plugs	M4.5 x 0.35 4-pin radial
Mounting Method	1/4-28 stud	5-40 stud	-	10-32 tapped hole
Sensitivity, mV/g (mV/m/s <sup>2</sup> )	5 (0.5)	10 (1)	100 (10)	10 (1)
Full Scale Range, g (m/s <sup>2</sup> )	1,000 (9,807)	500 (4,903)	50 (490)	200 (1,962)
Frequency Response, ±5%, Hz	1.6 to 2,500 (±3dB)	1 to 10,000	0.5 to 3,000	0 to 10,000 (±10%)
Maximum Shock Survivability, g (m/s <sup>2</sup> )	2,000 (19,613)	3,000 (29,420)	1,500 (14,710)	5,000 (49,033)
Operating Temperature Range, °F (°C)	-320 to +300 (-196 to +149)	-320 to +250 (-196 to +121)	-60 to +160 (-51 to +71)	-60 to +250 (-51 to +121)
Environmental Seal	hermetic	hermetic	hermetic	hermetic
Electrical Isolation	case	no	no	no
Compatible Cables	-	-	-	6776A
Features	cryogenic	cryogenic	triaxial seat pad conforms to ISO 8041	dual mode technology: incorporates AC and DC into one sensor extended low frequency response
Additional Series Variations	-	-	-	7705A2: 50 mV/g, 40g range 7705A3: 100 mV/g, 20g range
Similar Series	-	-	-	-

## 7705A Extended Low Frequency (ELF™) Series

## Dytran Instruments, Inc. Introduces The ELF™ Accelerometer



Unique ELF™ technology combines the most desirable features of piezoelectric sensors (excellent high frequency response) with those of variable capacitance MEMS accelerometers (true DC response) to create the widest possible bandwidth, from DC (0 Hz) to 10 kHz.

### What Can This Sensor Do For You?

ELF™ eliminates the need for using two different technologies (and two different sensors) to cover the bandwidth of interest in an application. Slow speed events in the sub-1Hz range and gear mesh frequencies up to 10 kHz can now be made using the same sensor. Static measurements such as angle and tilt are now possible in the same sensor that measures high frequency events. Hermetically sealed for use in rugged environments, from test tracks to outer space.

**Now one sensor can do it all!**



### Single Axis



Model Number	7500A1	7504A1	7531A1	7600B1
Weight, ounces (grams)	0.46 (13)	0.71 (20)	0.21 (6)	0.13 (3.6)
Size, inches (L x W x H)	1.00 x 1.00 x 0.33	0.90 x 0.90 x 0.31	.59 x .59 x .30	0.80 x 0.56 x 0.24
Connector Type	1/4-28 4-pin radial	5-foot integral cable to flying leads	80-inch integral cable to flying leads	M4.5 x 0.35 4-pin radial
Mounting Method	Ø.127 thru holes, x2	Ø.165 thru holes, x2	(2) M2 screws	(2) 4-40 screws
Sensitivity, mV/g (mV/m/s <sup>2</sup> )	1,000 (100)	2,000 (200)	420 (43) (±10%)	100 (10)
Full Scale Range, g (m/s <sup>2</sup> )	2 (20)	2 (20)	2 (20)	5 (49)
Frequency Response, 3dB, Hz	0 to 400	0 to 400	0 to 550	0 to 600
Output Noise, µg rms/√Hz	8 (78)	8 (78)	250 (2453)	9 (88)
Maximum Shock Survivability, g (m/s <sup>2</sup> )	2,000 (19,613)	5,000 (49,033)	10,000 (98,100)	2,000 (19,613)
Operating Temperature Range, °F (°C)	-67 to +257 (-55 to +125)	-67 to +257 (-55 to +125)	-40 to +185 (-40 to +85)	-40 to +248 (-40 to +120)
Environmental Seal	hermetic	epoxy	epoxy	hermetic
Compatible Cables	6854A, 6877A	-	-	6895A, 6948B, 6949A
Features	differential output ultra low noise MEMS technology	differential output cost effective	small footprint low mass cost effective	same power supply requirements as strain gage sensors differential output
Additional Series Variations	7500A2: 400 mV/g, 5g range 7500A3: 200 mV/g, 10g range 7500A4: 80 mV/g, 25g range 7500A5: 40 mV/g, 50g range 7500A6: 20 mV/g, 100g range 7500A7: 10 mV/g, 200g range 7500A8: 5 mV/g, 400g range	7504A2: 800 mV/g, 5g range 7504A3: 400 mV/g, 10g range 7504A4: 160 mV/g, 25g range 7504A5: 80 mV/g, 50g range 7504A6: 40 mV/g, 100g range 7504A7: 20 mV/g, 200g range 7504A8: 10 mV/g, 400g range	7531A2: 300 mV/g, 3g range 7531A3: 174 mV/g, 5g range 7531A4: 57 mV/g, 16g range 7531A5: 6.5 mV/g, 200g range	7600B2: 50 mV/g, 10g range 7600B3: 20 mV/g, 25g range 7600B4: 10 mV/g, 50g range 7600B5: 5 mV/g, 100g range 7600B6: 2.5 mV/g, 200g range
Similar Series	7500M10/M11: 3/8-28 "Mighty Mouse®" 4-pin radial connector, available in sensitivities of 5 and 40 mV/g	-	7533A Series: Triaxial	7602B: +5 VDC operation, available in sensitivities from 2.5 to 100 mV/g

### Single Axis



Model Number	7602B1	7604A1	7700A1	7701A1
Weight, ounces (grams)	0.13 (3.6)	0.13 (3.6)	0.28 (8)	0.28 (8)
Size, inches (L x W x H)	0.80 x 0.56 x 0.24	0.80 x 0.56 x 0.25	0.70 x 0.44 (D x H)	0.63 x 0.44 (D x H)
Connector Type	M4.5 x 0.35 4-pin radial	10-foot integral cable to flying leads	M4.5 x 0.35 4-pin radial	M5-5 4-pin radial
Mounting Method	(2) 4-40 screws	(2) 4-40 screws	10-32 tapped hole	10-32 tapped hole
Sensitivity, mV/g (mV/m/s <sup>2</sup> )	100 (10)	100 (10)	100 (10)	100 (10)
Full Scale Range, g (m/s <sup>2</sup> )	5 (49)	5 (49)	5 (49)	5 (49)
Frequency Response, 3dB, Hz	0 to 600	0 to 600	0 to 600	0 to 600
Output Noise, µg rms/√Hz	9 (88)	9 (88)	9 (88)	9 (88)
Maximum Shock Survivability, g (m/s <sup>2</sup> )	2,000 (19,613)	2,000 (19,613)	2,000 (19,613)	2,000 (19,613)
Operating Temperature Range, °F (°C)	-40 to +176 (-40 to +80)	-40 to +248 (-40 to +120)	-40 to +176 (-40 to +80)	-40 to +176 (-40 to +80)
Environmental Seal	hermetic	hermetic	hermetic	hermetic
Compatible Cables	6895A, 6948B, 6949A	-	6895A, 6948B, 6949A	6339A
Features	same power supply requirements as strain gage sensors differential output	same power supply requirements as strain gage sensors differential output	same power supply requirements as strain gage sensors differential output	same power supply requirements as strain gage sensors differential output
Additional Series Variations	7602B2: 50 mV/g, 10g range 7602B3: 20 mV/g, 25g range 7602B4: 10 mV/g, 50g range 7602B5: 5 mV/g, 100g range 7602B6: 2.5 mV/g, 200g range	7604A2: 50 mV/g, 10g range 7604A3: 20 mV/g, 25g range 7604A4: 10 mV/g, 50g range 7604A5: 5 mV/g, 100g range 7604A6: 2.5 mV/g, 200g range	7700A2: 50 mV/g, 10g range 7700A3: 20 mV/g, 25g range 7700A4: 10 mV/g, 50g range 7700A5: 5 mV/g, 100g range 7700A6: 2.5 mV/g, 200g range	7701A2: 50 mV/g, 10g range 7701A3: 20 mV/g, 25g range 7701A4: 10 mV/g, 50g range 7701A5: 5 mV/g, 100g range 7701A6: 2.5 mV/g, 200g range
Similar Series	7600B: +3 to +11 VDC operation, available in sensitivities from 2.5 to 100 mV/g	-	7701A: M5-5 4-pin radial connector, available in sensitivities from 2.5 to 100 mV/g	7700A: M4.5 x 0.35 4-pin radial connector, available in sensitivities from 2.5 to 100 mV/g

Triaxial



Model Number	5340B1	5346A1	7503D1	7533A1
Weight, ounces (grams)	0.46 (13)	0.46 (13)	1.34 (38)	0.21 (6)
Size, inches (L x W x H)	0.86 x 0.86 x 0.35	0.86 x 0.86 x 0.35	1.36 x 0.83 x 0.99	.59 x .59 x .30
Connector Type	1/4-28 4-pin radial	1/4-28 4-pin radial	5/16-32 9-pin radial	80-inch integral cable to flying leads
Mounting Method	Ø.15 thru holes, x2	Ø.15 thru holes, x2	1/4-28 tapped hole	(2) M2 screws
Sensitivity, mV/g (mV/m/s <sup>2</sup> )	-	-	2000 (204)	420 (42) (±10%)
Full Scale Range, g (m/s <sup>2</sup> )	16 (157)	14 (137)	2 (20)	2(20)
Frequency Response, 3dB, Hz	0 to 500	0 to 250	0 to 400	X&Y: 0 to 1,600 Z: 0 to 500
Output Noise, µg rms/√Hz	X & Y: 3.6; Z: 5.4	0.05	5 (49)	250 (2453)
Maximum Shock Survivability, g (m/s <sup>2</sup> )	10,000 (98,067)	10,000 (98,067)	2,000 (19,620)	10,000 (98,100)
Operating Temperature Range, °F (°C)	-40 to +185 (-40 to +85)	-40 to +185 (-40 to +85)	-40 to +250 (-40 to +121)	-40 to +185 (-40 to +85)
Environmental Seal	hermetic	hermetic	hermetic	epoxy
Compatible Cables	6330A (supplied)	6330A (supplied)	6956A, 6964A	-
Features	VibraScout 3D™ Portable, USB powered triaxial vibration measurement system	VibraScout 6D™ Portable, USB powered 6 DoF vibration measurement system	differential output ultra low noise MEMS technology	small footprint low mass cost effective
Additional Series Variations	5340B2: 200g range	5346A2: 200g range	7503D2: 800 mV/g, 5g range, 7503D3: 400 mV/g, 10g range, 7503D4: 160 mV/g, 25g range, 7503D5: 80 mV/g, 50g range, 7503D6: 40 mV/g, 100g range, 7503D7: 20 mV/g, 200g range, 7503D8: 10 mV/g, 400g range, 7503D9: 800 (x & y), 160 (z) mV/g, ±5(x & y), ±25(z) range, 7503D10: 800 (x & y), 160 (z) mV/g, ±5(x & y), ±50(z) range	7533A1: 420 mV/g, 2g range 7533A2: 300 mV/g, 3g range 7533A3: 174 mV/g, 5g range 7533A4: 57 mV/g, 16g range 7533A5: 6.5 mV/g, 200g range
Similar Series	5346A: VibraScout™ 6D	5340B: VibraScout™ 3D	-	7531A series: single axis

Triaxial



Model Number	7603B1
Weight, ounces (grams)	1.23 (35)
Size, inches (L x W x H)	0.90 x 0.90 x 0.90
Connector Type	5/16-32 9-pin radial
Mounting Method	1/4-28 tapped hole
Sensitivity, mV/g (mV/m/s <sup>2</sup> )	250 (25)
Full Scale Range, g (m/s <sup>2</sup> )	2 (20)
Frequency Response, 3dB, Hz	0 to 400
Output Noise, µg rms/√Hz	7 (69)
Maximum Shock Survivability, g (m/s <sup>2</sup> )	2,000 (19,613)
Operating Temperature Range, °F (°C)	-40 to +250 (-40 to +121)
Environmental Seal	hermetic
Compatible Cables	6956A, 6964A
Features	differential output ultra low noise MEMS technology
Additional Series Variations	7603B2: 100 mV/g, 5g range 7603B3: 50 mV/g, 10g range 7603B4: 20 mV/g, 25g range 7603B5: 10 mV/g, 50g range 7603B6: 5 mV/g, 100g range 7603B7: 2.5 mV/g, 200g range 7603B8: 1.25 mV/g, 400g range
Similar Series	

VibraScout™



Dytran Instruments, Inc. Introduces

The VibraScout™ 6D

The Dytran USB Digital 6 degrees of freedom sensor combines a 3-axis MEMS accelerometer, 3-axis gyroscope, and onboard temperature sensor with a microcontroller to create a smart sensor.

What Can This Sensor Do For You?

The VibraScout™ 6D is a USB compatible, "plug and play" portable, very affordable data acquisition system. Measure X,Y,Z acceleration, Roll, Pitch,Yaw and Temperature using a laptop or tablet with a USB port. Record, Measure and Analyze fast and efficiently using the VibraScout™ 6D!



## Adhesives

Model	Description
6273	mounting wax, 20 grams



6273

## Tools

Model	Description
6239	vibration probe, 0.5" hex, 6" long, 10-32 tapped hole, aluminum
6591A	installation and removal wrench, aluminum, 3225E and 3225F series
6725A	installation and removal wrench, aluminum, 3224A series
6741	installation and removal wrench, aluminum, 3133A series



6239



6591A



6725A



6741

## Adhesive Mounting Bases

Model	Hex Size (in)	Thickness (in)	Mounting Thread	Material
6167	0.375	0.125	2-56	stainless steel
6207	0.375	0.156	5-40	aluminum
6213	0.625	0.260	10-32	stainless steel
6221	0.625	0.180	10-32	aluminum
6228	0.500	0.200	10-32	aluminum



6213

6167

6207

6221

6228

## Mounting Isolation Adapters

Model	Hex Size (in)	Thickness (in)	Mounting Thread	Material
6222	0.375	0.156	5-40	aluminum
6223	0.375	0.340	10-32	aluminum
6226	0.625	0.180	10-32	aluminum
6243	0.375	0.280	10-32	aluminum
6244	0.375	0.375	10-32	aluminum
6245	0.625	0.375	10-32	aluminum
6268	0.312	0.140	5-40	aluminum
6714	0.560	0.340	4-40	aluminum



6222

6223

6226

6243

6244

6245

6268

6714

## Magnetic Mounting Bases

Model	Hex Size (in)	Thickness (in)	Mounting Thread	Material
6196	0.750	0.400	10-32	stainless steel
6199	0.375	0.210	2-56	stainless steel
6209	1.000	0.740	10-32	stainless steel
6258	0.625	0.390	10-32	stainless steel
6265	0.375	0.210	5-40	stainless steel
6272	0.625	0.430	10-32	stainless steel
6284	0.500	0.430	10-32	stainless steel
6295	0.250	0.120	flat surface for adhesive mount	stainless steel
6729	0.625	0.505	4-40	stainless steel



6196

6199

6209

DYTRAN 6258

6258

6265 DYTRAN

6265

DYTRAN 6272

6272

DYTRAN 6284

6284

6295

DYTRAN 6729

6729

Studs



Model	Threads			Material
6166	10-32	to	2-56	stainless steel
6176	1/4-28	to	1/4-28	stainless steel
6200	10-32	to	10-32	copper alloy
6200S	10-32	to	10-32	stainless steel
6201	10-32	to	1/4-28	copper alloy
6203	10-32	to	M6 x 1.0	copper alloy
6205	5-40	to	10-32	copper alloy
6580	5-40	to	5-40	copper alloy

Triaxial Mounting Blocks

Model	Dimensions (in)	Mounting	Material
6159	0.38 cube	flat surface for adhesive mount	stainless steel
6240A	1 cube	10-32	aluminum
6240S	1 cube	10-32	stainless steel
6241	0.75 cube	10-32	aluminum
6269	0.38 cube	5-40	aluminum
6552	2.5 cube	1/4-28	aluminum
6717	1.2 cube	4-40	aluminum

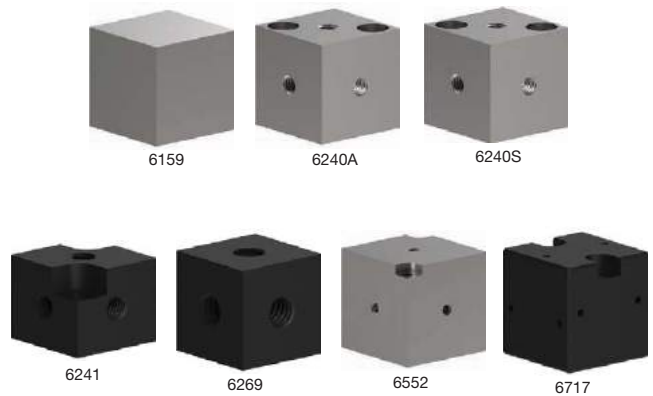

Mounting Screws



Model	Thread	Length (in)	Material
6164	6-32	0.75	stainless steel
6165	2-56	0.38	aluminum
6238A1	8-32	0.65	stainless steel
6238A2	8-32	0.75	stainless steel
6247A2	6-32	0.40	stainless steel
6297	6-32	0.54	stainless steel
6523	1/4-28	1.07	stainless steel
6524	1/4-28	0.89	stainless steel
6535	8-32	0.50	stainless steel
6545A1	4-40	0.31	stainless steel
6722	M2	0.47	stainless steel
6746	4-40	0.31	stainless steel
6914	M2	0.79	stainless steel

Immersion Proof™ and Protective Boots

Model	Hex (in)	Length (in)	Material
6185	0.9	3.4	Viton™
6194	1.1	2.67	Viton™
6529	0.94	3.87	Viton™





### Charge Mode



Model Number	2180C	2200C1	2300C1	2301C1
Weight, ounces (grams)	5.47 (155)	0.25 (7)	0.23 (6.5)	0.23 (6.5)
Size, inches (D x H)	0.98 x 2.60	0.22 x 1.32	0.22 x 1.32	0.22 x 1.20
Connector Type	TNC axial	10-32 axial	10-32 axial	10-32 axial
Mounting Method	1 1/8-12 thread	5/16-24 thread	5/16-24 thread	5/16-24 thread
Sensitivity, pC/psi (pC/kPa)	600 (87)	1 (0.16)	0.35 (0.05)	0.35 (0.05)
Full Scale Range, psi (kPa)	10 (69)	100 (689)	100 (689)	100 (689)
Maximum Pressure, psi (kPa)	600 (4,137)	10,000 (68,948)	15,000 (103,421)	15,000 (103,421)
Resonant Frequency, kHz	21	250	500	500
Maximum Shock Survivability, g (m/s <sup>2</sup> )	2,000 (19,613)	10,000 (98,067)	10,000 (98,067)	10,000 (98,067)
Operating Temperature Range, °F (°C)	-60 to +500 (-51 to +260)	-100 to +500 (-73 to +260)	-100 to +500 (-73 to +260)	-100 to +500 (-73 to +260)
Environmental Seal	hermetic	epoxy	hermetic	hermetic
Electrical Isolation	base	no	no	no
Compatible Cables	-	6013A, 6019A	6013A, 6019A	6013A, 6019A
Features	acceleration compensated high sensitivity microphone	acceleration compensated ultra fast rise time	acceleration compensated high natural frequency ultra fast rise time	acceleration compensated floating clamp nut ultra fast rise time
Additional Series Variations	-	2200C2: 500 psi range 2200C4: 1,000 psi range 2200C5: 5,000 psi range 2200C6: 10,000 psi range 2200C7: 15,000 psi range	2300C2: 500 psi range 2300C3: 1,000 psi range 2300C4: 3,000 psi range 2300C5: 5,000 psi range 2300C6: 10,000 psi range 2300C7: 15,000 psi range	2301C2: 500 psi range 2301C3: 1,000 psi range 2301C4: 3,000 psi range 2301C5: 5,000 psi range 2301C6: 10,000 psi range 2301C7: 15,000 psi range
Similar Series	-	2200V1: IEPE, 50 mV/psi, 100 psi range	2300V: IEPE, available in sensitivities from 0.33 to 20 mV/psi	2301B: IEPE, available in sensitivities from 0.33 to 20 mV/psi

### IEPE



Model Number	2005V	2006V1	2013D	2200V1
Weight, ounces (grams)	1.52 (43)	1.94 (55)	0.85 (24)	0.2 (6)
Size, inches (D x H)	0.31 x 2.03	0.31 x 1.70	0.62 x 1.17	0.22 x 1.32
Connector Type	TNC axial	2-pin MILC-5015 axial	10-32 axial	10-32 axial
Mounting Method	1/8-27 thread	1/4-18 thread	3/4-16 thread adaptor	5/16-24 thread
Sensitivity, mV/psi (mV/kPa)	100 (14.5)	10 (1.45)	2,000 (290)	50 (7.3)
Full Scale Range, psi (kPa)	50 (345)	500 (3,447)	2.5 (17)	100 (689)
Maximum Pressure, psi (kPa)	1,000 (6,895)	8,000 (55,158)	20 (138)	1,000 (6,895)
Resonant Frequency, kHz	90	50	50	300
Maximum Shock Survivability, g (m/s <sup>2</sup> )	10,000 (98,067)	10,000 (98,067)	500 (4,903)	10,000 (98,067)
Operating Temperature Range, °F (°C)	-100 to +275 (-73 to +135)	-40 to +250 (-40 to +121)	-60 to +250 (-51 to +121)	-100 to +250 (-73 to +121)
Environmental Seal	hermetic	hermetic	hermetic	hermetic
Electrical Isolation	base	case	none	no
Compatible Cables	6410A	6038A	6010A, 6011A	6010A, 6011A
Features	probe-style	acceleration compensated fast rise time	fast rise time low noise high natural frequency	acceleration compensated ultra fast rise time
Additional Series Variations	-	2006V2: 50 mV/psi, 100 psi range 2006V3: 100 mV/psi, 50 psi range	-	-
Similar Series	-	-	-	2200C: charge mode, available in ranges from 100 to 15,000 psi

IEPE



Model Number	2300V1	2301B1
Weight, ounces (grams)	0.21 (6)	0.18 (5)
Size, inches (D x H)	0.22 x 1.32	0.22 x 1.23
Connector Type	10-32 axial	10-32 axial
Mounting Method	5/16-2 thread	5/16-24 thread
Sensitivity, mV/psi (mV/kPa)	20 (2.9)	20 (2.9)
Full Scale Range, psi (kPa)	250 (1,724)	250 (1,724)
Maximum Pressure, psi (kPa)	18,000 (124,106)	5,000 (34,474)
Resonant Frequency, kHz	500	500
Maximum Shock Survivability, g (m/s <sup>2</sup> )	10,000 (98,067)	10,000 (98,067)
Operating Temperature Range, °F (°C)	-100 to +250 (-73 to +121)	-100 to +250 (-73 to +121)
Environmental Seal	hermetic	hermetic
Electrical Isolation	no	no
Compatible Cables	6010A, 6011A	6010A, 6011A
Features	acceleration compensated high natural frequency ultra fast rise time	acceleration compensated floating clamp nut high natural frequency ultra fast rise time
Additional Series Variations	2300V3: 10 mV/psi, 500 psi range 2300V4: 5 mV/psi, 1,000 psi range 2300V5: 1 mV/psi, 5,000 psi range 2300V6: 0.5 mV/psi, 10,000 psi range 2300V7: 0.33 mV/psi, 15,000 psi range	2301B3: 10 mV/psi, 500 psi 2301B4: 5 mV/psi, 1,000 psi 2301B5: 1 mV/psi, 5,000 psi 2301B6: 0.5 mV/psi, 10,000 psi 2301B7: 0.33 mV/psi, 15,000 psi
Similar Series	2300C: charge mode, available in ranges from 100 to 15,000 psi	2301C: charge mode, available in ranges from 100 to 15,000 psi



Mounting Adapters

Model	Description
6230	hollow clamp nut or model 2013D
6501	1/8 NPT mounting adapter for 0.217-inch diaphragm sensors, 5/16-24 internal thread
6502	3/8-24 mounting adapter for 0.217-inch diaphragm sensors, 5/16-24 internal thread
6503	3/8-24 mounting adapter for 0.217-inch diaphragm sensors, M7 x 0.75 internal thread
6507	hollow clamp nut for model 2301B
6520	3/8-24 isolation adapter for 0.217-inch diaphragm sensors, Delrin (100 psi maximum pressure)
6522	thermal isolation adapter for 0.217-inch diaphragm sensors, 6-32 internal thread



Pressure Seals

Model	Inner Diameter (in)	Outer Diameter (in)	Thickness (in)	Material
6600	0.218	0.250	0.015	brass
6600S	0.218	0.250	0.015	stainless steel
6600T	0.218	0.250	0.015	Teflon™
6601	0.375	0.437	0.030	brass
6606	0.250	0.320	0.020	brass
6607B	0.620	0.070	0.060	brass
6607D	0.620	0.070	0.060	delrin
6620	1.062	1.350	0.020	copper



### Charge Mode



Model Number	1050C	1051C	1060C	1061C
Weight, ounces (grams)	1.13 (32)	1.13 (32)	12.23 (460)	14.82 (420)
Size, inches (D x H)	0.75 x 0.62	0.75 x 0.63	2.00 x 1.25	2.00 x 1.25
Connector Type	10-32 axial	10-32 radial	10-32 axial	10-32 radial
Mounting Method	1/4-28 tapped hole	1/4-28 tapped holes	3/8-16 tapped hole	3/8-16 tapped holes
Sensitivity, pC/lbf (pC/N)	18 (4.45)	18 (4.45)	9 (2)	9 (2)
Compression Range, lbf (kN)	5,000 (22.24)	5,000 (22.24)	25,000 (111.21)	25,000 (111.21)
Maximum Compression, lbf (kN)	15,000 (66.72)	15,000 (66.72)	60,000 (266.89)	60,000 (266.89)
Tension Range, lbf (kN)	500 (2.22)	500 (2.22)	500 (2.22)	500 (2.22)
Maximum Tension, lbf (kN)	1,000 (4.45)	1,000 (4.45)	1,000 (4.45)	1,000 (4.45)
Maximum Shock Survivability, g (m/s <sup>2</sup> )	10,000 (98,067)	10,000 (98,067)	5,000 (49,033)	5,000 (49,033)
Operating Temperature Range, °F (°C)	-100 to +500 (-73 to +260)	-100 to +500 (-73 to +260)	-100 to +500 (-73 to +260)	-100 to +500 (-73 to +260)
Environmental Seal	epoxy	epoxy	epoxy	epoxy
Compatible Cables	6013A, 6019A	6013A, 6019A	6013A, 6019A	6013A, 6019A
Features	high natural frequency high stiffness	high natural frequency high stiffness	general purpose	general purpose
Additional Series Variations	-	-	-	-
Similar Series	1050V: IEPE, available in sensitivities from 1 to 500 mV/lbf	1051V: IEPE, available in sensitivities from 1 to 500 mV/lbf	1060V: IEPE, available in sensitivities from 0.1 to 10 mV/lbf	1061V: IEPE, available in sensitivities from 0.1 to 10 mV/lbf

### Charge Mode



Model Number	1210C1
Weight, ounces (grams)	0.4 (12)
Size, inches (D x H)	0.65 x 0.31
Connector Type	10-32 radial
Mounting Method	Ø.26 thru hole
Sensitivity, pC/lbf (pC/N)	18 (4.45)
Compression Range, lbf (kN)	5,000 (22.24)
Maximum Compression, lbf (kN)	10,000 (44.48)
Tension Range, lbf (kN)	-
Maximum Tension, lbf (kN)	-
Maximum Shock Survivability, g (m/s <sup>2</sup> )	-
Operating Temperature Range, °F (°C)	-60 to +400 (-51 to +204)
Environmental Seal	hermetic
Compatible Cables	6013A, 6019A
Features	ring style configuration
Additional Series Variations	1210C2: 10,000 lbf range 1210C3: 20,000 lbf range 1210C4: 40,000 lbf range 1210C5: 60,000 lbf range 1210C6: 80,000 lbf range 1210C7: 100,000 lbf range
Similar Series	-

### Force Sensor Accessories



- 6210S Impact cap for series 1050 and 1051, stainless steel, 1/4-28 integral stud
- 6210A Impact cap for series 1050 and 1051, aluminum, 1/4-28 integral stud
- 6232 Mounting stud for 1061V, 1061C force sensor, 3/8-16 thread, beryllium copper
- 6204 Mounting stud, 1/4-28 to 1/4-28, beryllium copper
- 6217 Impact cap for series 1060 and 1061, stainless steel, 3/8-16 integral stud

## IEPE



Model Number	1022V	1050V1	1051V1	1053V1
Weight, ounces (grams)	0.16 (4.5)	1.13 (32)	0.99 (28)	0.99 (28)
Size, inches (D x H)	0.40 x 0.49	0.75 x 0.62	0.75 x 0.63	0.75 x 0.63
Connector Type	60-inch integral cable to 10-32 plug	10-32 axial	10-32 radial	10-32 radial
Mounting Method	10-32 tapped holes	1/4-28 tapped hole	1/4-28 tapped holes	10-32 tapped holes
Sensitivity, mV/lbf (mV/N)	100 (22.5)	500 (112)	500 (112)	500 (112)
Compression Range, lbf (kN)	50 (0.22)	10 (0.04)	10 (0.04)	10 (0.04)
Maximum Compression, lbf (kN)	100 (0.44)	200 (0.89)	200 (0.89)	200 (0.89)
Tension Range, lbf (kN)	50 (0.22)	10 (0.04)	10 (0.04)	10 (0.04)
Maximum Tension, lbf (kN)	75 (0.33)	200 (0.89)	200 (0.89)	200 (0.89)
Maximum Shock Survivability, g (m/s <sup>2</sup> )	5,000 (49,033)	10,000 (98,067)	10,000 (98,067)	10,000 (98,067)
Operating Temperature Range, °F (°C)	-100 to +250 (-73 to +121)	-100 to +250 (-73 to +121)	-100 to +250 (-73 to +121)	-100 to +250 (-73 to +121)
Environmental Seal	epoxy	epoxy	epoxy	epoxy
Compatible Cables	6011A	6010A, 6011A	6010A, 6011A	6010A, 6011A
Features	miniature, lightweight design	high stiffness high natural frequency	high stiffness high natural frequency	high stiffness high natural frequency
Additional Series Variations	-	1050V2: 100 mV/lbf, 50 lbf range 1050V3: 50 mV/lbf, 100 lbf range 1050V4: 10 mV/lbf, 500 lbf range 1050V5: 5 mV/lbf, 1,000 lbf range 1050V6: 1 mV/lbf, 5,000 lbf range	1051V2: 100 mV/lbf, 50 lbf range 1051V3: 50 mV/lbf, 100 lbf range 1051V4: 10 mV/lbf, 500 lbf range 1051V5: 5 mV/lbf, 1,000 lbf range 1051V6: 1 mV/lbf, 5,000 lbf range	1053V2: 100 mV/lbf, 50 lbf range 1053V3: 50 mV/lbf, 100 lbf range 1053V4: 10 mV/lbf, 500 lbf range 1053V5: 5 mV/lbf, 1,000 lbf range 1053V6: 1 mV/lbf, 5,000 lbf range
Similar Series	-	1050C: charge mode, 5,000 lbf range	1051C: charge mode, 5,000 lbf range	-

## IEPE



Model Number	1060V1	1061V1	1203V1
Weight, ounces (grams)	16.23 (460)	15.94 (254)	1.76 (50)
Size, inches (D x H)	2.00 x 1.25	2.00 x 1.25	1.10 x 0.50
Connector Type	10-32 axial	10-32 radial	10-32 radial
Mounting Method	3/8-16 tapped hole	3/8-16 tapped holes	Ø.40 thru hole
Sensitivity, mV/lbf (mV/N)	10 (2)	10 (2)	50 (11)
Compression Range, lbf (kN)	500 (2.22)	500 (2.22)	100 (0.44)
Maximum Compression, lbf (kN)	10,000 (44.48)	10,000 (44.48)	200 (0.89)
Tension Range, lbf (kN)	500 (2.22)	500 (2.22)	-
Maximum Tension, lbf (kN)	1,000 (4.45)	1,000 (4.45)	-
Maximum Shock Survivability, g (m/s <sup>2</sup> )	5,000 (49,033)	5,000 (49,033)	10,000 (98,067)
Operating Temperature Range, °F (°C)	-100 to +250 (-73 to +121)	-100 to +250 (-73 to +121)	-100 to +250 (-73 to +121)
Environmental Seal	epoxy	epoxy	hermetic
Compatible Cables	6011A	6011A	6011A
Features	wide frequency range	wide frequency range	ring style configuration
Additional Series Variations	1060V2: 5 mV/lbf, 1,000 lbf range 1060V3: 1 mV/lbf, 5,000 lbf range 1060V4: 0.5 mV/lbf, 10,000 lbf range 1060V5: 0.2 mV/lbf, 25,000 lbf range 1060V6: 0.1 mV/lbf, 50,000 lbf range	1061V2: 5 mV/lbf, 1,000 lbf range 1061V3: 1 mV/lbf, 5,000 lbf range 1061V4: 0.5 mV/lbf, 10,000 lbf range 1061V5: 0.2 mV/lbf, 25,000 lbf range 1061V6: 0.1 mV/lbf, 50,000 lbf range	1203V2: 10 mV/lbf, 500 lbf range 1203V3: 5 mV/lbf, 1,000 lbf range 1203V4: 1 mV/lbf, 5,000 lbf range 1203V5: 0.5 mV/lbf, 10,000 lbf range
Similar Series	1060C: charge mode, 25,000 lbf range	1061C: charge mode, 25,000 lbf range	-



### Impulse Hammers



Model Number	5800B2	5800SL	5802A	5803A
Head Weight, ounces (grams)	3.53 (100)	0.07 (2)	48 (3 pounds)	192 (12 pounds)
Electrical Connection	BNC jack	10-32 jack	BNC jack	BNC jack
Sensitivity, mV/lbf (mV/N)	100 (23)	100 (23)	1 (0.22)	1 (0.22)
Full Scale Range, lbf (kN)	50 (0.22)	50 (0.22)	5,000 (22.24)	5,000 (22.24)
Maximum Force, lbf (kN)	1,000 (4.45)	75 (0.33)	10,000 (44.48)	10,000 (44.48)
Compatible Cables	6055A, 6089A	6011A	6020A	6020A
Features	industry standard size	ultra miniature	3-pound head weight	12-pound head weight
Additional Series Variations	5800B3: 50 mV/lbf, 100 lbf range 5800B4: 10 mV/lbf, 500 lbf range 5800B5: 5 mV/lbf, 1,000 lbf range	-	-	-
Similar Series	5800BT: TEDS, available with sensitivities from 5 to 100 mV/lbf	-	5802AT: TEDS, 1 mV/lbf, 5,000 lbf range	5803AT: TEDS, 1 mV/lbf, 5,000 lbf range

### Impulse Hammers



Model Number	5805A	5850B
Head Weight, ounces (grams)	16 (1 pound)	5.3 (150)
Electrical Connection	BNC jack	BNC jack
Sensitivity, mV/lbf (mV/N)	1 (0.22)	100 (23), 10 (2) and 1 (0.22) user selectable
Full Scale Range, lbf (kN)	5,000 (22.24)	50 (0.22), 500 (2.22), and 5,000 (22.24) user selectable
Maximum Force, lbf (kN)	10,000 (44.48)	1,000 (4.45), 6,000 (26.69), 8,000 (35.59)
Compatible Cables	6020A	6055A, 6089A
Features	1-pound head weight	3-position toggle switch allows user to select from 3 different sensitivities for use with test objects of varying size
Additional Series Variations	-	-
Similar Series	-	-

### Head Extenders

Model	Description
6270S1	for use with model 5850B, stainless steel, 1-inch long
6270S2	for use with model 5850B, stainless steel, 2-inches long
6271	for use with 5800B series, stainless steel, 1-inch long
6278	for use with model 5800SL, brass, 0.167-inches long



Impact Tips

Model	Description
6250A	for use with 5800B and 5850B, aluminum, hard, 1/4-28 thread
6250C	for use with 5800B and 5850B, copper, hard, 1/4-28 thread
6250P	for use with 5800B and 5850B, delrin, hard, 1/4-28 thread
6250PS	for use with 5800B and 5850B, polyurethane, super soft, 1/4-28 thread
6250S	for use with 5800B and 5850B, stainless steel, hard, 1/4-28 thread
6250PT	for use with non-Dytran impulse hammers, delrin, hard, 10-32 thread
6250PST	for use with non-Dytran impulse hammers, polyurethane, super soft, 10-32 thread



Model	Description
6530H	for use with 5805A, hard, 1/4-20 thread
6530M	for use with 5805A, medium, 1/4-20 thread
6530S	for use with 5805A, soft, 1/4-20 thread
6530T	for use with 5805A, tough, 1/4-20 thread
6251H	for use with 5802A, hard, 3/8-16 thread
6251M	for use with 5802A, medium, 3/8-16 thread
6251S	for use with 5802A, soft, 3/8-16 thread
6251T	for use with 5802A, tough, 3/8-16 thread
6252H	for use with 5803A, hard, 1/2-13 thread
6252M	for use with 5803A, medium, 1/2-13 thread
6252S	for use with 5803A, soft, 1/2-13 thread
6252T	for use with 5803A, tough, 1/2-13 thread



In-Line Charge Amplifiers



Model Number	4705A1	4705M4	4711A1	4751B1
Sensitivity, mV/pC	50	10	0.1	50
Range, pC	100	500	50,000	100
Size, inches (L x D)	3.13 x 0.50	2.56 x 0.50	2.53 x 0.50	1.81 x 0.50
Connectors (Input / Output)	BNC jack / BNC jack	10-32 jack / BNC jack	10-32 jack / BNC plug	10-32 jack / 10-32 jack
Features	general purpose	general purpose	general purpose	general purpose
Additional Series Variations	4705A2: 10 mV/pC, 500 pC range 4705A3: 1 mV/pC, 5,000 pC range 4705A4: 0.1 mV/pC, 50,000 pC range	4705M5: 1 mV/pC, 5,000 pC range 4705M11: 50 mV/pC, 100 pC range 4705M22: 0.5 mV/pC, 10,000 pC range	4711A2: 1 mV/pC, 5,000 pC range 4711A3: 10 mV/pC, 500 pC range	4751B2: 10 mV/pC, 500 pC range 4751B3: 1 mV/pC, 5,000 pC range 4751B4: 0.1 mV/pC, 50,000 pC range
Similar Series	-	-	-	4751B1T: TEDS, available in sensitivities from 0.1 to 50 mV/pC

In-Line Charge Amplifiers



Model Number	4752B	4753B	4754B
Sensitivity, mV/pC	10	10	10
Range, pC	500	500	500
Size, inches (L x D)	1.83 x 0.50	2.46 x 0.50	1.83 x 0.50
Connectors (Input / Output)	10-32 jack / 10-32 jack	10-32 jack / BNC jack	10-32 jack / 10-32 jack
Features	for use with high temperature sensors	for use with high temperature sensors	for use with high temperature sensors
Additional Series Variations	-	4753B1: 1 mV/pC, 5,000 pC range	-
Similar Series	4752B1T: TEDS, 10 mV/pC, 500 pC range	-	-



### IEPE Current Source Power Units



Model Number	4102C	4103C	4105C	4110C
Channels	1	3	1	1
Size, inches (H x W x D)	2.9 x 4.0 x 2.1	3.3 x 5.3 x 2.5	2.9 x 4.0 x 2.3	5.5 x 1.6 x 8.0
Connectors (Input / Output)	BNC jack / BNC jack	BNC jack / BNC jack	BNC jack / BNC jack	BNC jack / BNC jack
Power Source	9V batteries (2 each)	9V batteries (2 each)	9V batteries (2 each)	50-60 Hz, line
Gain	unity	unity	x1, x10, x100	unity
Features	battery operated	battery operated	battery operated	bench-top, line operated

### IEPE Current Source Power Units



Model Number	4112B	4114B1	4115B
Channels	1	4	1
Size, inches (H x W x D)	5.4 x 1.8 x 8.1	5.4 x 1.8 x 8.1	5.4 x 1.8 x 8.1
Connectors (Input / Output)	BNC jack / BNC jack	BNC jack / BNC jack	BNC jack / BNC jack
Power Source	50-60 Hz, line	50-60 Hz, line	50-60 Hz, line
Gain	unity	unity	unity
Features	bench-top, line operated	bench-top, line operated	bench-top, line operated

### IEPE Current Source Power Units



Model Number	4116	4121	4123B
Channels	16	12	12
Size, inches (H x W x D)	1.8 x 19.0 x 11.1	1.8 x 19.0 x 12.3	1.8 x 19.0 x 10.8
Connectors (Input / Output)	BNC jack / BNC jack	BNC jack / BNC jack	BNC jack / BNC jack
Power Source	115V/220V 50-60 Hz line or external 24 VDC	115V/220V 50-60 Hz line or external 24 VDC	115V/220V 50-60 Hz line
Gain	unity	unity	x1, x10, x100
Features	rack mounted	rack mounted	rack mounted

IEPE Current Source Power Units



Model Number	4129	4130	4139
Channels	6	12	6
Size, inches (H x W x D)	1.8 x 19.0 x 10.6	1.75 x 19.0 x 12.5	0.94 x 6.25 x 4.0
Connectors (Input / Output)	BNC jack / BNC jack	BNC jack / BNC jack	10-32 jack / DA-15P
Power Source	115V/220V 50-60 Hz line	115V/220V 50-60 Hz line	+28 VDC
Gain	true RMS to DC converter	true RMS to DC converter	unity
Features	rack mounted	rack mounted	for airborne applications

Signal Conditioners



Model Number	4010	4020
Channels	3	3
Size, inches (H x W x D)	3.3 x 8.3 x 9.3	3.3 x 8.3 x 9.3
Connectors (Input / Output)	D-SUB, 9-pin / BNC jack	BNC jack / BNC jack
Power Source	50-60 Hz, line	50-60 Hz, line
Gain	0.01 to 9999	0.01 to 9999
Features	for use with DC sensors	for use with charge mode and IEPE sensors

Vibration Meters



Model Number	4151HL	4190
Dimensions, inches	5.2 x 3.1 x 8.1	5.3 x 3.3 x 2.5
Weight, grams	1,077	318
Connector	BNC jack / BNC jack	BNC jack / BNC jack
Supply Current / Voltage	4/20	2/18
Accuracy @ 1 kHz	±2	±2
Operating Temperature Range, °F (°C)	180 (82)	180 (82)
Sensitivities Supported, mV/g	10, 100	10, 100
Full Scale Ranges Support, g	1, 5, 10, 50	2, 20, 50
Frequency Response, Hz	1 to 28,000	20 to 5,000
DC Output Signal, VDC	0 to 10	N/A

TEDS Adapter



The Dytran model 4025A TEDS (Transducer Electronic Data Sheet) adapter is IEEE 1451.4 compliant and designed for interfacing a standard voltage mode, piezoelectric type (IEPE) sensor to a TEDS compatible signal conditioning unit. The model 4025A is connected in series with the non-TEDS compatible sensor and a TEDS compatible signal conditioning unit. The utility of the 4025A is that it allows the user to adapt non-TEDS, IEPE type sensors that may already be in use, into the TEDS environment. The 4025A can be used with an IEPE type device. Contact the factory for application support concerning the proper use of the 4025A adapter.



## For Sensors with 10-32 Connectors

Model	Connector A	Description	Connector B
6010A	10-32 plug	Coaxial, Teflon™ jacket, white	10-32 plug
6011A	10-32 plug	Coaxial, Teflon™ jacket, white	BNC plug
6012A	10-32 plug	Coaxial, Teflon™ jacket, white	BNC jack
6032A	10-32 plug	Coaxial, Teflon™ jacket, white	10-32 plug right angle
6033A	10-32 plug	Coaxial, Teflon™ jacket, white	cutoff
6093A	10-32 plug	Coaxial, PVC jacket, RG174, black	BNC plug
6099A	10-32 hex plug	Coaxial, Teflon™ jacket, white	BNC plug
6400A	10-32 plug	Coaxial, PVC jacket, RG174, black	10-32 plug
6412A	10-32 plug	Coaxial, PVC jacket, RG174, black	cutoff
<b>Flexible</b>			
6016A	10-32 plug	Coaxial, PVC jacket, gray	10-32 plug
6018A	10-32 plug	Coaxial, silicone rubber jacket, white	cutoff
6022A	10-32 plug	Coaxial, silicone rubber jacket, white	10-32 plug
6053A	10-32 plug	Coaxial, PVC jacket, gray	BNC plug
6054A	10-32 plug	Coaxial, PVC jacket, gray	cutoff
6066A	10-32 plug	Coaxial, silicone rubber jacket, white	BNC plug
<b>Low Noise</b>			
6002A	10-32 plug	Coaxial, Teflon™ jacket, red	cutoff
6013A	10-32 plug	Coaxial, Teflon™ jacket, red	10-32 plug
6019A	10-32 plug	Coaxial, Teflon™ jacket, red	BNC plug
6037A	10-32 plug	Coaxial, PVC jacket, orange	cutoff
6039A	10-32 plug	Coaxial, PVC jacket, orange	BNC plug
6057A	10-32 plug	Coaxial, Teflon™ jacket, red	BNC jack
6061A	10-32 plug	Coaxial, PVC jacket, orange	10-32 plug
6417A	10-32 hex plug	Coaxial, Teflon™ jacket, red	BNC plug
<b>High Shock</b>			
6036A	10-32 Hypershock™ plug	Coaxial, Teflon™ jacket, red, low noise	10-32 plug
6049A	10-32 Hypershock™ plug	Coaxial, Teflon™ jacket, red, low noise	BNC plug
6050A	10-32 solder terminal plug	Two conductor ribbon, Teflon™ jacket, white	cutoff
6051A	10-32 solder terminal plug	Two conductor ribbon, Teflon™ jacket, white	10-32 solder terminal plug
6869A	10-32 plug	Two conductor ribbon, Teflon™ jacket, white	BNC plug
<b>Rugged / Armored</b>			
6026A	10-32 plug	Coaxial, armored RG196/AU	10-32 plug
6069A	10-32 plug	Coaxial, armored RG196/AU	BNC plug
6097A	10-32 hex plug	Coaxial, armored, low noise, lockwire holes	10-32 hex plug
6411A	10-32 hex plug	Coaxial, armored, low noise, lockwire holes	BNC plug



10-32 Plug



10-32 Hex Plug



BNC Jack



10-32 Hypershock™ plug



10-32 Solder Terminal Plug

For Sensors with 5-44 Connectors

Model	Connector A	Description	Connector B
6014A	5-44 plug	Coaxial, PVC jacket, gray	10-32 plug
6021A	5-44 plug	Coaxial, silicone rubber jacket, white	cutoff
6024A	5-44 plug	Coaxial, silicone rubber jacket, white	10-32 plug
6028A	5-44 plug	Coaxial, PVC jacket, gray	cutoff
6040A	5-44 plug	Coaxial, PVC jacket, gray	BNC plug
<b>Low Noise</b>			
6025A	5-44 plug	Coaxial, Teflon™ jacket, red	10-32 plug
6056A	5-44 plug	Coaxial, Teflon™ jacket, red	BNC plug
<b>Rugged</b>			
6017A	5-44 plug	Coaxial, Teflon™ jacket, white	10-32 plug
6029A	5-44 plug	Coaxial, Teflon™ jacket, white	BNC plug
6092A	5-44 plug	Coaxial, armored RG196A/U	BNC plug



5-44 Plug



BNC Plug

For Sensors with BNC Connectors

Model	Connector A	Description	Connector B
6020A	BNC plug	Coaxial, PVC jacket, RG-58A/U, black	BNC plug
6055A	BNC plug	Coaxial, Teflon™ jacket, RG196A/U, white	BNC plug
6088A	BNC plug	Two conductor, polyurethane jacket, black	cutoff
6089A	BNC plug	Coaxial, PVC jacket, RG174, black	BNC plug
6094A	BNC plug	Coaxial, PVC jacket, RG-58A/U, black	cutoff
6098A	BNC plug	Coaxial, Teflon™ jacket, white	cutoff
6409A	BNC plug	Two conductor, Tefzel™ jacket, white	cutoff
6426A	BNC plug	Coaxial, polyurethane jacket, black	BNC plug
6429A	BNC plug	Coaxial, Teflon™ jacket, RG196A/U, white	10-32 right angle plug



10-32 Right Angle Plug

For Sensors with TNC Connectors

Model	Connector A	Description	Connector B
6086A	TNC plug	Coaxial, Tefzel™ jacket, white	BNC plug
6087A	TNC plug	Two conductor, Tefzel™ jacket, white	cutoff
6090A	TNC plug	Two conductor, polyurethane jacket, black	cutoff
6091A	TNC plug	Coaxial, PVC jacket, RG58A/U, black	BNC plug
6404A	TNC plug	Coaxial, PVC jacket, RG58A/U, black	cutoff
6405A	TNC plug	Coaxial, Tefzel™ jacket, white	cutoff
6410A	TNC plug	Coaxial, PVC jacket, RG174A/U, black	BNC plug



TNC Plug

For Sensors with MIL-C-5015 Connectors

Model	Connector A	Description	Connector B
6038A	10SL-4P	Coaxial, PVC jacket, RG58A/U, black	BNC plug
6080A	10SL-4P	Two conductor, polyurethane jacket, black	cutoff
6082A	10SL-4P	Two conductor, polyurethane jacket, RG58A/U, black	BNC plug
6406A	10SL-4P	Two conductor, Tefzel™ jacket, white	cutoff
6407A	10SL-4P	Two conductor, Tefzel™ jacket, white	BNC plug



2-pin Military



## For DC Sensors

Model	Connector A	Description	Connector B
6854A	4-pin	Four conductor, Teflon™ jacket, black	cutoff
6895A	4-pin	Four conductor, Teflon™ jacket, white	cutoff
6949A	4-pin	Four conductor, Teflon™ jacket, white, miniature	D-SUB 9-pin
6956A	9-pin	Eight conductor, Teflon™ jacket, white	(3) D-SUB 9-pin



## For Triaxial Sensors

Model	Connector A	Description	Connector B
6428A	4-pin	Coaxial, PVC jacket, black	(3) BNC plugs
6430A	4-pin	Coaxial, Teflon™ jacket, white	(3) BNC plugs
6431A	4-pin	Four conductor, PVC jacket, white	(3) 10-32 plugs
6801A	4-pin	Coaxial, PVC jacket, white, flexible	(3) BNC plugs
6811A	4-pin	Four conductor, Teflon™ jacket, white	(3) BNC plugs
6812A	4-pin	Four conductor, Teflon™ jacket, black	cutoff
6824A	4-pin	Four conductor, Santoprene™ jacket, black, flexible	(3) BNC plugs
6828A	4-pin	Four conductor, Teflon™ jacket, black	(3) 10-32 plugs
6893A	4-pin	Four conductor, Teflon™ jacket, white	(3) BNC plugs
6918A	4-pin	Four conductor, Santoprene™ jacket, black	cutoff
6925A	4-pin	Four conductor, Santoprene™ jacket, black	(3) 10-32 plugs
6937A	4-pin	Four conductor, Santoprene™ jacket, black	(3) BNC plugs

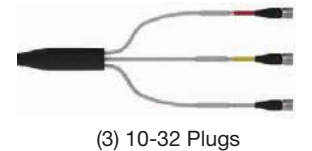
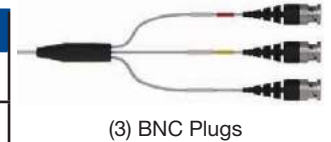

## For Specialty Sensors

Model	Connector A	Description	Connector B
6003A/B	3-56 plug	Coaxial, Teflon™ jacket, orange, low noise	10-32 jack
6838A	2-pin	Two conductor, Teflon™ jacket, white, low noise, high temperature	cutoff
6845A	2-pin	Two conductor, Teflon™ jacket, white, low noise, high temperature	6-pin
6891A	"Mighty Mouse®"	Three conductor, Teflon™ jacket, white	cutoff
6894A	10-32 plug	Hardline, stainless steel jacket, silver	10-32 plug
6930A	10-32 plug	Coaxial, Teflon™ jacket, orange, flight rated	BNC plug
6933A	4-pin	Coaxial, Teflon™ jacket, red, flight rated	(3) BNC plugs



# CUSTOMER BENEFITS PROGRAMS

## The Dytran Difference



### **Sensor Select 100™ Inventory Stocking Program with Lifetime Warranty**

Sensor Select 100™ is our new inventory stocking program that keeps one hundred of our most popular models in stock and at the ready, waiting for your order to ship! The Sensor Select 100™ program is designed for rapid delivery of our most popular products when you need them, where you need them. Sensor Select 100™ products are backed by an enhanced “Best in Class” Lifetime Warranty against defects in materials and workmanship for as long as you own the product. Now you can look for small quantities of the most popular Dytran sensors without having to tour the entire product line. Visit our website to find out more about this exciting new Sensor Select 100™ Benefit!

### **Sensor Select 100™ Total Customer Satisfaction Money Back Guarantee**

If at any time during the first year from date of original shipment from Dytran you are unhappy with a Sensor Select 100™ product, we'll give you your money back. Your feedback is essential to making Dytran better, so please assist us by letting us know the reason for return. Note: Offer applies to Sensor Select 100™ stocking program only.

### **5-Year Standard Product, 2-Year Modified Product, 1-Year Cable & Accessories Warranty**

Dytran Standard Products come with an industry-leading 5-year warranty. If any product fails for defects in materials and workmanship up to 5 years after date of original shipment from Dytran, we will repair or replace it – free. Additionally, Modified "M-Number" Products are warranted to be free of defects in materials and workmanship for a period of two years after shipment. Cables and Accessories are warranted to be free of defects in materials and workmanship for a period of one year after shipment.

### **The Quad™ Sensor Educational Donations**

The Quad™ offers a unique opportunity for undergraduate and graduate degree engineering students and faculty members to obtain Dytran sensors for their thesis papers and research experiments free of charge. Sensors listed on The Quad™ are fully calibrated to their precise performance values and are working properly, but some may be slightly “off-specification.” Check factory for details. The only requirement is that students and faculty/staff receiving sensors from The Quad™ send their work to us to post on our website when complete. Find out more about this exciting program today!

### **Sensor Exchange™ Qualified Sensor Trade-In Program**

Dytran customers are offered an additional Sensor Select™ Benefit when you trade in qualifying competitive IEPE, Charge Mode and DC response MEMS sensors for an equivalent Dytran model. Customers may receive up to 15% off the purchase price of any NEW Dytran equivalent model (ask our Sales Applications Engineers for assistance in determining qualifying models).





Dytran Founder, Nick Change

### Dytran Celebrating 35 Years!

#### A Word About Our Founder:

Dytran Founder and Chairman Nicholas D. Change began his long technical career in 1950 as a draftsman at Bell Aircraft Co.(Wheatfield, NY). In 1952, Nick was drafted and served in the U.S. Army until 1954. After completing his military service, Nick returned to Bell until 1961 when he joined Kistler Instrument Corp. (Clarence, NY) as a manufacturing product line manager. While at Kistler, Nick began his career in piezoelectric transducer design. Working full time and going to school at night, Nick completed his BSEE degree at the University of Buffalo in 1965. In 1970, Nick joined PCB Piezotronics (Depew, NY) as Technical Director and later served as its President before re-joining Kistler in 1979 as President. Driven by a desire to bring innovative new designs to the market, Nick founded Dytran in West Seneca, NY (a suburb of Buffalo) in September, 1980. (Nick formed the company name "Dytran" by combining the words "Dynamic" and "Transducer.") In 1983, Dytran moved to Los Angeles, CA to better serve its developing customer base in the aircraft and aerospace industries.

With the founding of Dytran, Nick became one of the most prolific piezoelectric transducer designers of his day. He turned out accelerometers, force sensors, impulse hammers, pressure sensors, current source power units, vibration meters, charge amplifiers, cables, and a blinding array of accessory items in non-stop rapid succession. A multiple patent holder, Nick was the sole design engineer at Dytran for the first 20 years of the business; some of his legacy designs are still among the most popular Dytran products.

The company Nick founded now employs over 160 people and operates from a 35,000 square foot facility in Chatsworth, CA. Nick was joined at the beginning of Dytran by three of his children (Michael, David, and Anne) who today serve as Officers and Directors. Dytran has expanded its product line beyond piezoelectric technology to include DC-MEMS based accelerometers and digital output, USB-powered triaxial accelerometers. Dytran continues to spur exciting sensor technology innovations for others to follow!

Nick is now enjoying semi-retirement, but remains active in product development. His most recent achievements are the "World's Smallest" single axis IEPE accelerometer, Model 3224A, and the ultra-miniature IEPE triaxial Model 3133A - both are top-sellers for Dytran. Nick's tenacity, inventiveness, customer-oriented approach, and "can-do" attitude helped make Dytran the company it is today. Our people, products and policies reflect that tradition and we look forward to serving you!

Michael R. Change  
President



At Bell Aircraft, circa 1950's



Precision Assembly



In-house Machining



21592 Marilla Street, Chatsworth, CA 91311 • Phone (818) 700-7818  
Fax (818) 700-7880 • Email [info@dytran.com](mailto:info@dytran.com) • Web [www.dytran.com](http://www.dytran.com)  
AS9100 CERTIFIED • A2LA ACCREDITED TO ISO 17025 • ISO 9001 CERTIFIED