

Design & engineering simulation solutions

Smarter CAE, virtual manufacturing & costing



About MSC Software

Accelerate smart change with CAE simulation

MSC Software develops predictive simulation software technology that enables engineers to validate and optimize their manufactured product or process designs using virtual prototypes. Customers in almost every part of manufacturing use our software to complement, and in some cases even replace the physical prototype “build and test” process that has traditionally been used in product design. We partner with our customers to help improve quality, save time and reduce costs associated with design and test of manufactured products. Our products accurately and reliably predict how products will behave in the real world to help engineers design more innovative products - quickly, cost effectively and right-first-time.

MSC Software’s technology is used by leading manufacturers for linear and nonlinear finite element analysis (FEA), acoustics, fluid-structure interaction (FSI), multi-physics, optimization, fatigue and durability, multi-body dynamics, electro-mechanical drivelines, and control systems simulation. MSC pioneered many of the technologies that are now relied upon by industry to analyze and predict stress and strain, vibration & dynamics, acoustics, and thermal analysis in our flagship product, MSC Nastran.

The McNeal Schwendler Corporation (MSC) was formed in 1963 and was awarded the original contract from NASA to commercialize the finite element analysis (FEA) software known as NASTRAN (NASA Structural Analysis). MSC pioneered many of the technologies that are now relied upon by industry to analyze and predict stress and strain, vibration & dynamics, acoustics, and thermal analysis in our flagship product, MSC Nastran. Over our rich history, MSC has developed or acquired many other well-known CAE applications including Patran, Adams, Marc, Dytran, CAEfatigue, SimManager, Easy5, Sinda, Actran, Digimat, Cradle CFD, VTD, FormingSuite, MSC Apex, Romax, and Simufact. We are committed to the continued development of new CAE technology that integrates disciplines and technologies from standalone CAE tools into unified multi-discipline solvers and user environments. Our solutions enable engineers to improve the reliability and accuracy of their virtual prototypes by including multi-physics and multi-discipline interactions. MSC is also the CAE industry’s leader in extending simulation to the engineering enterprise with Engineering Lifecycle Management solutions for materials and CAE data.

Our products and services are used by 900 of the top 1000 manufacturers in the world, spanning industries like:

- Aerospace and defense
- Agriculture
- Automotive and ground transportation
- Consumer products
- Electronics
- Heavy machinery
- Materials
- Medical devices
- Oil and gas
- Power Generation
- Renewable energy

Our customers recognize the need to scale the benefits of virtual prototyping and testing from research of experts to mainstream engineering analysts and product development. MSC offers a Materials Data and Process Management platform as well as the only Simulation Data and Process Management solution in the world that has been successfully deployed in industries including automotive, aerospace, shipbuilding, electronics, and more. MSC Software Corporation is part of Hexagon (Nasdaq Stockholm HEXA:B) after its acquisition in 2017, a leading global provider of information technologies that drive productivity and quality across geospatial and industrial enterprise applications. MSC Software currently employs nearly 1500 employees in over 20 countries.



Message from our CEO

Dr. Roger Assaker

For half a century, MSC Software has been delivering certainty to our customers. By simulating the reality of complex manufactured systems through our software, we deliver certainty so our users can delight their customers with great products, and certainty in business results by reducing time to bring the right products to market, reduce physical testing and warranty claims long after product design is over.

We do this by pushing the edge of physics simulation and the latest computing technology to simulate real world behaviors. These principles that MSC was founded upon continue as our guiding light under Hexagon. We help to make cars safer and more efficient, airplanes more aerodynamic and more comfortable for passengers, ships stronger and able to travel longer distances, machinery to run more efficiently and with less maintenance, and medical devices more effective to help us live longer.

Our customers are faced with difficult questions every day; can I reduce the time it takes to develop? Will it work? Will it be innovative? Will it be safe? Will it be fuel efficient? Will it provide a new standard of passenger comfort? Will it last longer? Will it allow me to beat my competitors? By knowing exactly how products will behave before they are built, manufacturers can deliver better products faster, with more reliability, and without worrying about recalls. Our software also allows you to comply with environmental and legislative standards and deliver sustainable manufacturing.

The first adopter of CAE simulation technology was the aerospace industry. The challenge of safe flight from the very first test onwards drove it to push the state-of-the-art in technology, long before any other industry. MSC became and has remained a trusted partner with the world's leading aerospace companies, delivering certainty every step of the way. In 2003, NASA put a value to society in excess of 10 billion dollars on the NASTRAN structural analysis simulation software delivered by MSC. Eventually, this kind of simulation technology became broadly adopted in nearly every industry from automotive to machinery, energy to infrastructure, consumer products to electronic devices. Virtually every major OEM and manufacturer in the world is an MSC customer today. Call us, find out more, and see how we are enabling the future of autonomy and helping you make things smarter in the 21st century.



Roger Assaker - CEO, MSC Software and EVP Design and Engineering Software, Manufacturing Intelligence division, Hexagon



Table of contents

About MSC Software	2
Message from the CEO	3
Table of contents	4
Our solution portfolio	6
MSC One	7
Unlock the world of engineering simulation with our portfolio token system	
MSC Apex Generative Design	10
Automated lightweight design optimization	
MSC Apex Modeler	12
Direct modeling & meshing solution Discipline: Structures & multiphysics	
MSC Apex Structures	14
Computational parts based structural analysis Discipline: Structures & multiphysics	
Adams	16
Multibody dynamics simulation solution Discipline: Mechanisms & multibody dynamics	
Romax Nexus	18
Complete ecosystem of applications for electromechanical simulation Discipline: Electromechanical	
Actran	22
Powerful acoustic simulation software Discipline: Acoustics	
MSC CoSim	24
Where multiphysics gets real	
Cradle CFD	25
Multiphysics focused computational fluid dynamics software	
Digmat	28
Nonlinear multi-scale material and structure modeling platform Discipline: Materials	

Our solution portfolio

Industry-leading simulation portfolio

MSC Software makes products that enable engineers to validate and optimize their designs using virtual prototypes and digital twins. Customers across all manufacturing industries use our software to complement, and in some cases even replace the physical prototyping for product and process design, development, testing and deployment to eventual retirement or recycling.

Hexagon's MSC Software product portfolio

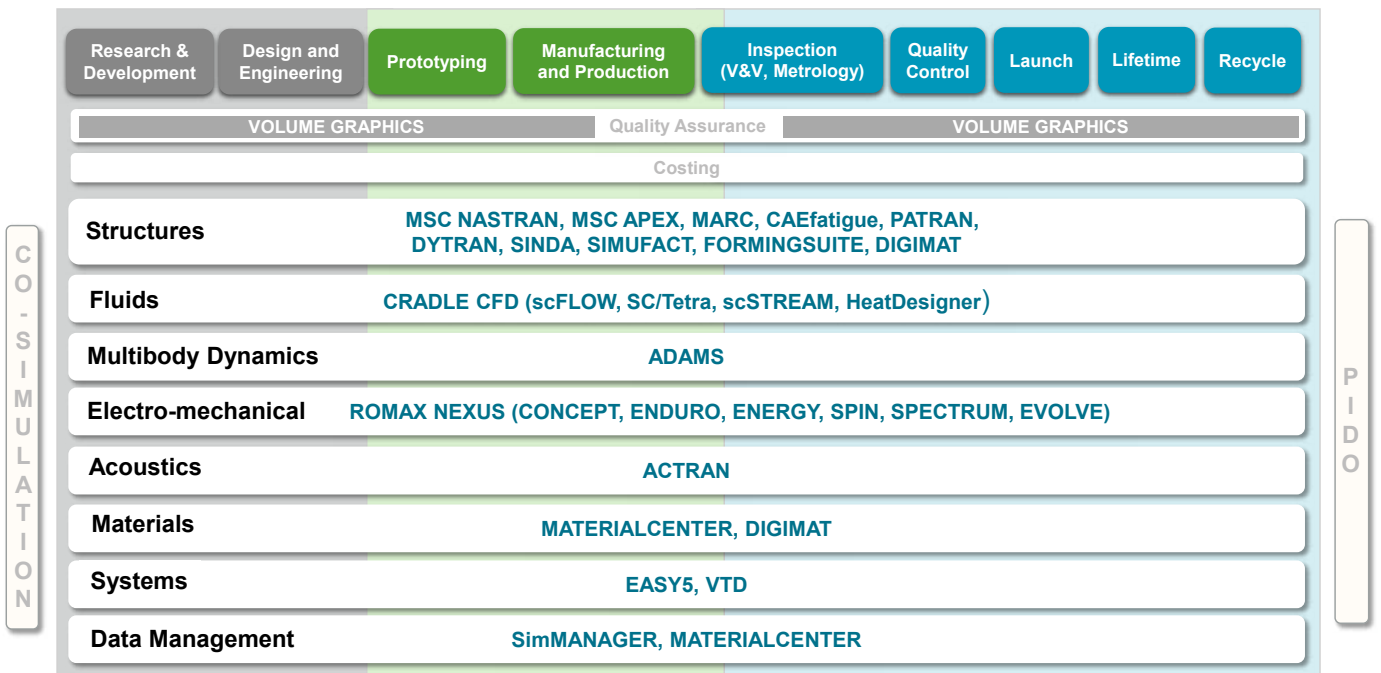



MSCOne

Unlock the world of engineering simulation with our portfolio token system.

MSCOne is a product token system that lets you take advantage of the breadth and depth of MSC Software's simulation portfolio within a flexible token-based licensing system*.

Typically offered on an annual subscription basis, MSCOne provides efficient implementation of your investment in product development with access to a suite of multidisciplinary engineering software tools.

Key aspects of MSCOne include:

- As a subscription product, MSCOne's capacity can be expanded or contracted based on current and future project needs.
- Access to more connected physics and disciplines allows better prediction of part and system's multiphysics behaviour.
- Ability to leverage MSC's ecosystem of products including; MSC Apex, MSC Nastran, Patran, Adams, Marc, SimManager, MaterialCenter and more.
- Substantially all current and future MSC products will be available in MSCOne.

With the subscription-based token system, you receive a pool of tokens. Your tokens are checked out from the pool and are used to access and run a full range of CAE solutions available under the MSCOne licensing system.

Each individual software item requires a certain number of tokens to run. After each use, your tokens are returned to the pool for other use. There are dozens of software items available under MSCOne.

Who is it for?

- Large-scale global enterprises.
- Small-medium sized companies with tight budgets and heavy engineering needs.
- Consulting firms that cannot invest in multiple outright per-seat purchases.

**Exceptions do apply with certain products. Please talk with your MSC representative for more information.*

How MSCOne Works

MSCOne^{SE} Starter Edition

Get started with the most cost effective and flexible token system for your simulation needs.

MSCOne^{SE} is a flexible token-based licensing system that provides access to many of MSC Software's key structural and fluid simulation portfolio*.

Typically offered on an annual subscription basis, MSCOne^{SE} provides a low cost, low risk entry point for those looking to get started with a suite of multidisciplinary engineering software tools.

- Access to core structural and fluid simulation tools to allow for better prediction of part and system multiphysics behaviour.
- Tiered entry price point depending on number of users.
- Perfect for small to medium sized companies and consulting firms with tight budgets and heavy engineering needs.



MSCOne^{XT} Extended Edition

Extend the most powerful token system to take you further with trusted partner tools.

MSCOne^{XT} is an extension to MSCOne. MSCOne^{XT} provides access to an ever-evolving suite of software tools that have been developed by MSC Software's technology partners to complement the solution portfolio within the MSCOne token system.

- MSCOne^{XT} uses your existing tokens and unlocks access to complementary third-party tools.
- Provides access to one simultaneous session of all third-party partner tools at no additional cost*.
- Extends the capability and usability of existing MSCOne tools with complementary partner products.



**Exceptions do apply with certain products. Please talk with your MSC representative for more information.*

Packed with all the simulation tools you need, and growing.

We are constantly updating, improving and adding to our portfolio. If you want to see what's currently included in MSCOne^{SE}, MSCOne or MSCOne^{XT}. Explore a smarter way to access simulation software at www@mscsoftware.com/mscone.

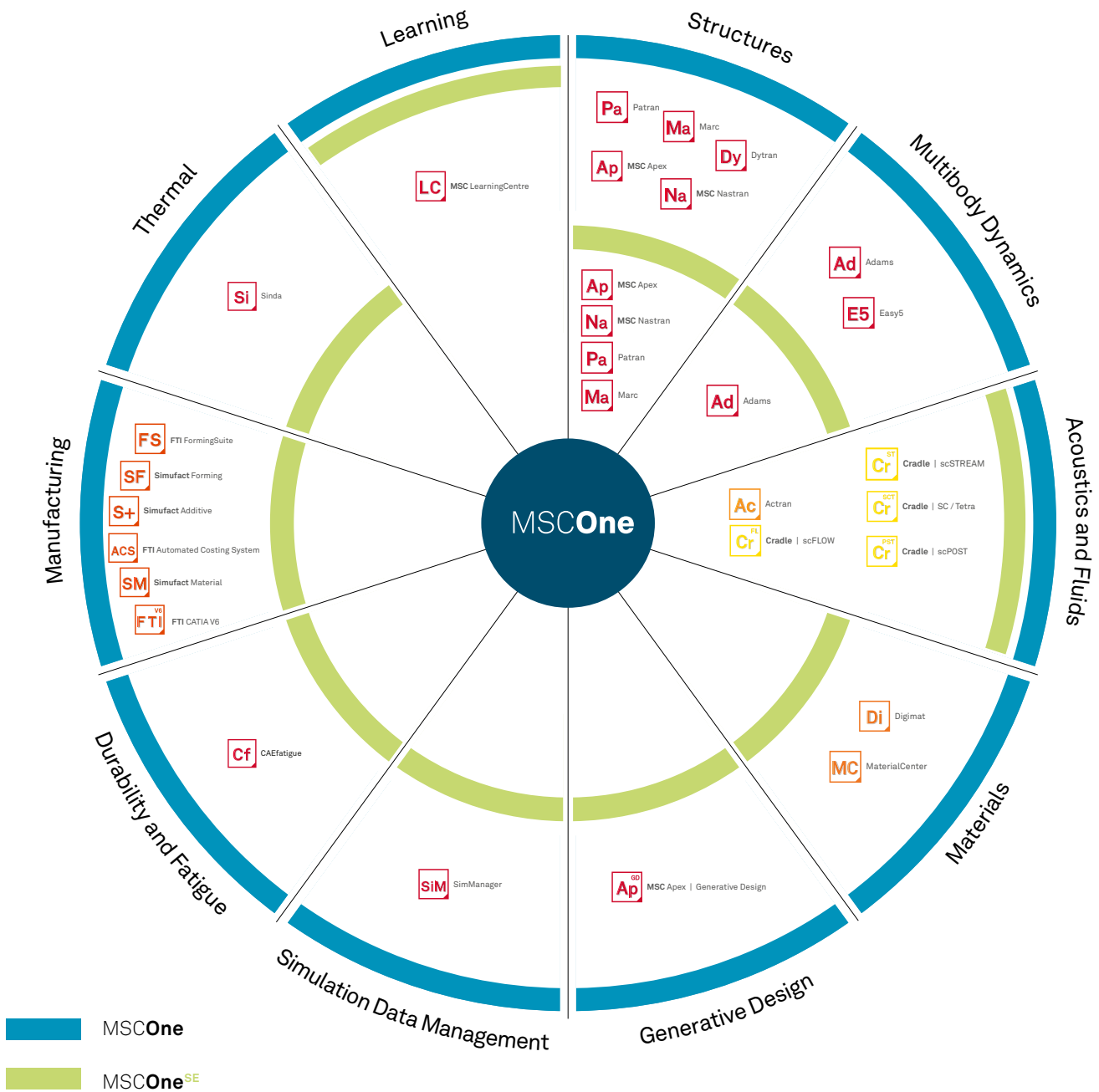

MSC Apex | Generative Design

Automated lightweight design optimization

MSC Apex Generative Design is the fully automated generative design solution built on the intuitive CAE environment MSC Apex. It exploits all the easy-to-use and easy-to-learn features of MSC Apex while employing an innovative generative design engine in the background. This combination of advantages dramatically decreases the effort required in the design optimization workflow.

MSC Apex Generative Design is designed specifically to generate the detailed and highly complex structures that only additive processes can manufacture. The innovative, stress-based algorithm derives distinct geometries by minimizing mass, creating geometries that are truly unimaginable by the human mind.

- **Simplicity:** No expert knowledge required for conducting optimizations through a high user-focused software design
- **Automated design:** Almost automatically generate multiple smoothed design candidates that all satisfy the design criteria while minimizing the weight.
- **Import and validation:** Import existing geometries or mesh, find optimized design candidates, and perform design validation – all inside a single CAE environment.
- **Direct output:** Export geometry that can be directly manufactured and used immediately without manual re-work.
- **One process:** Import the resulting geometries in Simufact Additive or Digimat AM to achieve cost-efficient first-time-right result for every part

Productivity gains

A race car's wheel carrier with 9 load cases was optimized within 8 hours instead of usually more than 1.5 weeks of work. The optimization's result is an already smoothed geometrically and mechanically correct design that is ready for manufacturing. By cutting the weight through the optimization to almost 50% production runtime and costs were significantly reduced.

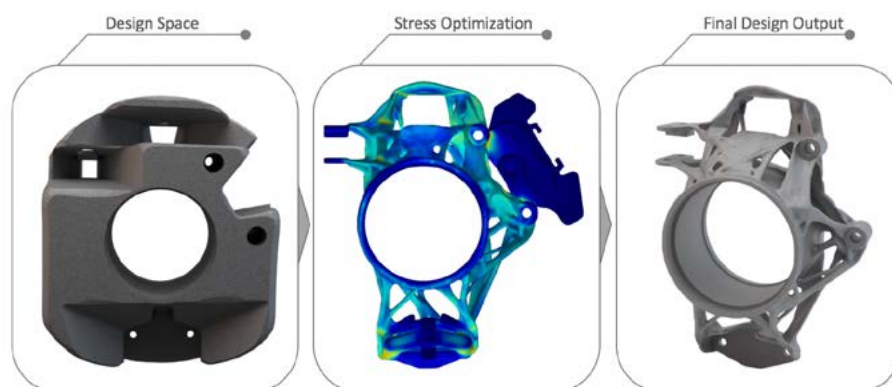



Capabilities

- Import CAD files
- Direct and fast creation of (multiple) optimization model(s)
- Automated optimization process of linear static load cases
- Integrated smoothing for clean surfaces & perfectly shaped transitions between struts and shell structure
- Significant weight reduction through a stress based algorithm
- Generative design studies to create a variety of results in a short time
- Solving on CPU, Nvidia GPUs and remotely on Windows & Linux
- Intersection
- Local Coordinate Systems, Pressure, Gravity

Benefits

- New, innovative design mindset – no manual construction necessary
- Easy-to-use software does not require an extensive training period
Cost savings through a much more efficient process of product design
- Multiple design candidates generated based on optimization settings
- Direct and feasible part design output
- Generated results are tailored for a direct Additive Manufacturing production and utilize the technology's potentials
- Interoperability for mechanical integrity validation and manufacturability
- Generation of highly complex, organic shaped lightweight designs for reduced production and operation costs

MSC Apex | Modeler

Direct modeling and CAD-and-Mesh solution

MSC Apex Modeler is a CAE specific direct modeling and CAD-and-Mesh solution that streamlines CAD clean-up, mesh creation and attributes setting workflow. The solution features sophisticated and interactive tools that are easy to use and easy to learn.

- **Smart tools:** MSC Apex features a complete set of direct modeling tools to make geometry clean-up and idealization steps in an extremely fast and efficient manner. Simply select the entities of interest and push/pull or drag to implement any modifications. Such tools allow users to clean up geometry without any prerequisite experience and can reduce the number of user operations by a factor of 10.
- **Product workflows:** MSC Apex has also been architected with smart FEA/CAE workflows in mind. A representative example is the smart mid-surfacing capabilities that enable the fast converging of 3D FEA models to 2D models. Users can easily achieve 10x productivity gains in a typical CAD to analysis-ready FEA workflow by employing the workflows provided by MSC Apex.
- **Underlying technologies:** MSC Apex incorporates a generative framework to enable full associativity between the geometry and analysis data. Once the 'upstream' object has modifications, the change will be synchronized to 'downstream' objects automatically, including mesh, attributes, and even simulation results. This Direct-modeling is unique in the CAE industry and provides a tremendous user experience benefits.
- **Easy to use, easy to learn:** MSC Apex is designed to have multi-purpose tools to make the application easy to use. It also features numerous learning aids such as tutorials, video-based documentation, workflow and at-mouse instructions which promotes single day productivity

Productivity gains

Geometry creation and meshing of this aerospace bulkhead required 50 hours with conventional CAE tools. In MSC Apex Modeler, the process only took 5.5 hours and required little effort to extract mid-surfaces, connect separate surfaces, mesh, and assign thicknesses and offsets.



	Today's Workflow	MSC Apex Workflow
Expertise Required	High	Low
Analysis geometry creation	35h	3h
Mesh creation	3h	2h
Property Assignments	12h	
Complete entire scenario	50h	5.5h

Capabilities

Sketching

- Sketch lines, squares, circles, ellipsoids, fillets, chamfers and high-order geometries
- Project, split, and edit existing sketches

Geometry edit with direct modeling

- Identify features and automatic defeature
- Interactively edit solids and surfaces with Push/Pull or Vertex/Edge drag
- Split and fill surfaces
- Add/Remove and Suppress/Un-suppress vertices or edges
- Support automatic part replacement in an assembly

Midsurface creation and repair tools

- Extract mid-surfaces by auto offset, constant thickness, distance offset, or tapered methods
- Incrementally build mid-surfaces of uniform or non-uniform thickness for planar or curved solids

Geometry extraction from orphan mesh

- Generate, modify and re-use/re-mesh faceted and 'real' NURBS geometry from legacy FEA models
- Modify and update facet geometry zones with user control
- Recognize 2D and 3D features for subsequent geometry edits
- Export retrieved geometry to widely used file format

Meshing and mesh editing

- Mesh curves, surfaces, and solids, available element types: Beam, Quad, Tria, Tet, Hex
- Regenerate meshes automatically as geometry is modified
- Refine meshes with Feature Base Meshing, mesh Seeding and mesh control curve

- Construct Hard Points to facilitate part connection
- Mesh surfaces via paver, 4 side map, or 4+ side map mesh methods
- Visually inspect element quality

Model attribution

- Material Creation and Assignment
- Behavior Creation and Assignment
- Automatic creation of thickness and offset properties for uniform and non-uniform cross sections
- Definition of interaction tools, including Ties and Discrete Connectors
- Definition of gravity load, point load, enforced motion, constraints and press load

Interoperability with gold-standard solvers

- Continuously extended import, export and MSC Nastran-generated data support
- "Abstraction" concept for closer Apex/MS Nastran integration
- Support access to Adams/Car model/results data for post-processing
- Enable Geometry association and loads mapping between Adams/Car result data and structural FEA model in a single environment

Productive post-processing

- Embed image/movie capture function in GUI
- Enable multi-view result exploration environment

Automation via Python-based API

- Allow user-defined tools to automate repetitive work and develop in-house workflow
- Provide full IDE support
- Support Macro record and reply without coding

MSC Apex | Structures

Computational parts based structural analysis

MSC Apex Structures is an integrated module of a Finite Element Analysis solver, which provides users access to linear (and very soon, nonlinear) structural analysis. Currently, Apex supports four types of linear analysis, including linear statics, linear buckling, normal modes, and frequency response analysis.

MSC Apex Structures is a package with an intuitive user interface for scenario definition, analysis readiness check, and integrated solver. The integration of the user interface with solvers gives users a unique ability to interactively and incrementally validate and solve FEA models. This Incremental Validation and Solution philosophy is a creative and intelligent revolution to the very time-consuming traditional FEA workflow where pre/post processor and solver are separate.

With continuously extended supports of “MSC Apex - MSC Nastran - MSC Apex” workflow, users can pick the best scenario according to different design stages and tasks:

Scenario 1 – External MSC Nastran solution

Many existing MSC Nastran users will determine to use MSC Nastran as an external solver, due to their in-house process and/or client requirements.

Scenario 2 – Integrated MSC Apex Structures solution to support external MSC Nastran solution

The integrated solver can be used for incremental building and validation of FEA models as they are developed. Once verified as working representations, the run-ready FEA models can be solved externally with MSC Nastran, for subsequent result exploration through MSC Apex.

Scenario 3 – Embedded MSC Apex Structures solution

In the case where an MSC Nastran solution is not mandatory, the user can take advantage of the full capability of the embedded MSC Apex solver.

Productivity gains

Computational Parts technology was used to perform an incremental analysis of this landing gear door assembly. After modifying one part of the assembly, an incremental or subsequent analysis completed 2.5x faster than its first solve.

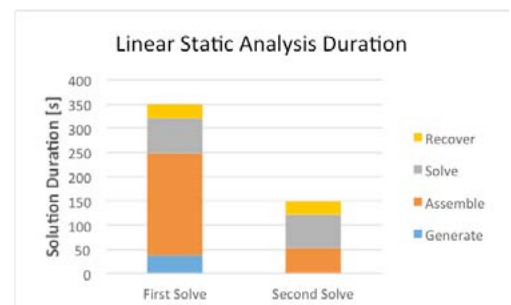
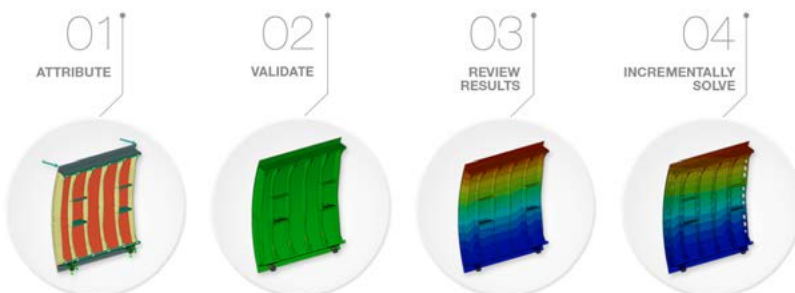

Capabilities

Linear structural analysis

Offer 4 types of linear simulations

- Linear Statics Analysis
- Linear Buckling Analysis
- Normal Modes Analysis
- Frequency Response Analysis

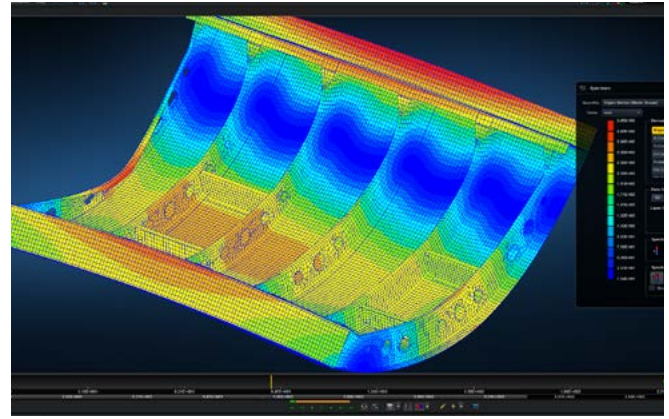

Incremental validation and solving

- Automatic Analysis Readiness check that covers geometry integrity, mesh quality, materials properties, loads and constraints, interactions, and simulation settings
- Manage multiple scenarios (model representations, output requests, analysis type)
- Context-specific calculation (Part, Sub-assembly, Assembly)

Generative framework

- Quickly update simulation results when “upstream” objects are modified

Adams

Multibody dynamics simulation solution

Adams is our gold standard software that helps engineers study the dynamics of moving parts, and how loads and forces are distributed throughout mechanical systems. Product manufacturers often struggle to understand true system performance until very late in the design process. Mechanical, electrical, and other subsystems are validated against their specific requirements within the systems engineering process, but full-system testing and validation comes late, leading to rework and design changes that are riskier and more expensive than those made early on.

As the world's most famous, widely used and award winning Multibody Dynamics (MBD) software, Adams improves engineering efficiency and reduces product development costs by enabling early system-level design validation. Engineers can evaluate and manage the complex interactions between disciplines including motion, structures, actuation, and controls to better optimize product designs for performance, safety, and comfort. Along with extensive analysis capabilities, Adams is optimized for large-scale problems, taking advantage of high performance computing environments.

Utilizing multibody dynamics solution technology, Adams runs nonlinear dynamics in a fraction of the time required by FEA solutions. Loads and forces computed by Adams simulations improve the accuracy of FEA by providing better assessment of how they vary throughout a full range of motion and operating environments. With Adams, you don't have to wait until the computations are complete to begin seeing the results of your simulation. You can view animations and plots – and continue to refine your design – even as your simulation is running, saving valuable time. For design optimization, you can define your variables, constraints, and design objectives, then have Adams iterate automatically to the design, providing optimal system performance.

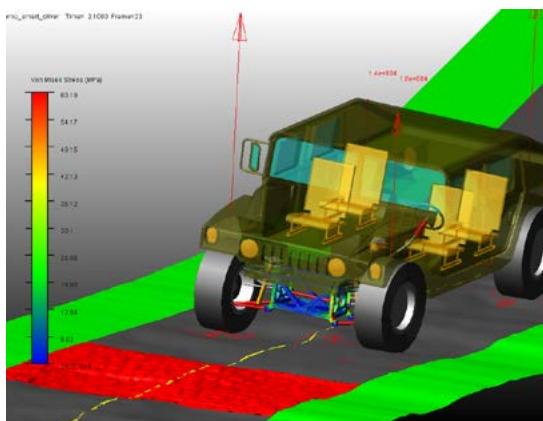

Adams/Car

- Explore the performance of your design and refine your design before building and testing a physical prototype
- Analyze design changes much faster and at a lower cost than physical prototype testing would require
- Vary the kinds of analyses faster and more easily
- Work in a more secure environment without the fear of losing data from instrument failure or losing testing time because of poor weather conditions

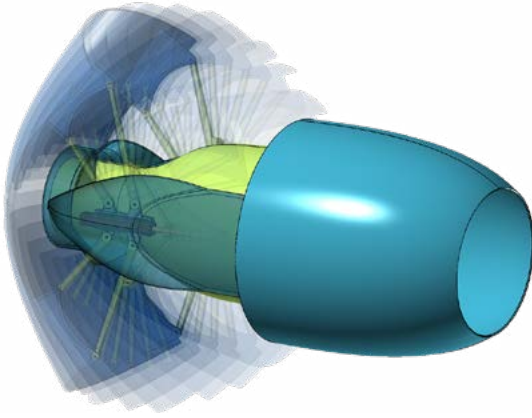

Adams/Machinery

- High-fidelity simulation of common mechanical parts, such as gears, bearings, belts, chains, Electric Motor and Cam
- Enhanced productivity with incredibly quick model-solve-evaluate process times
- An automated, wizard-driven model creation process for ease-of-use
- Straightforward evaluation of results in Adams/Postprocessor

Capabilities

- Import of CAD geometry formats including STEP, IGES, DXF, DWG or Parasolid
- Extensive library of joints and constraints to define part connectivity
- Definition of internal and external forces on the assembly to define your product's operating environment
- Model refinement with part flexibility, automatic control systems, joint friction and slip, hydraulic and pneumatic actuators, and parametric design relationships
- Ability to generate flexible parts without the need to import MNF file from FEA software
- Ability to iterate to optimal design through definition of objectives, constraints, and variables
- Automatic generation of linear models and complex loads for export to structural analyses
- Comprehensive and easy to use contact capabilities supporting 2D and 3D contact between any combination of modal flexible bodies and rigid body geometry
- Comprehensive linear and nonlinear results for complex, large-motion designs
- Incorporate geometric and material nonlinearity through Adams-Marc co-simulation
- Create geometric nonlinear beam parts using FE part

Adams Real Time

- Connect real equipment and virtual models in a HIL test environment to test system interactions.
- Connect a real driver and virtual models in a DIL test environment to assess vehicle and Driver performance
- Connect Adams and VTD to capture high frequency responses in autonomous simulations

High performance computing (HPC)

- Parallel processing support for Adams/Tire results
- Shared Memory Parallel solver
- State of the art Linear analysis capabilities
- High fidelity Adams-to-Nastran translation utilities to replace manual translation
- HHT integrators for a faster numerical integration of the equations of motion for a dynamic analysis



Romax Nexus

Complete ecosystem of applications for electro-mechanical simulations for gearboxes, drivetrains and bearings

Romax Nexus is a portfolio of industry-leading and award-winning electro-mechanical simulation applications. From rapid modelling and concept exploration to detailed simulation and virtual product sign-off, Romax Nexus applications align with your drivetrain and transmission development cycle. Intelligently integrated into the wider CAE world, Romax Nexus empowers your teams and enables Right First Time designs.

- Romax Concept: rapid creation, sizing and exploration of drivetrain architectures to establish design direction and derisk development
- Romax Enduro: trusted structural simulation and optimisation for the design of durable and robust electro-mechanical drive systems
- Romax Spectrum: full system NVH simulation from gear and electric machine design through to vehicle sound quality
- Romax Energy: a global efficiency prediction tool for drivetrains and transmissions
- Romax Spin: advanced simulation of rolling element bearings for bearing designers and application engineers
- Romax Evolve: electro-mechanical analysis tool for electrical machine designers

All Romax Nexus products offer a whole system holistic approach using an engineering-based parametric definition of each component. The fast and easy-to-use modelling process, along with interfaces to all major CAD and FEA packages, leads to a seamless design process bringing CAE even earlier in your development cycle. The rapid analysis engine, repeatedly validated in a wide range of industries and suitable for multiple levels of fidelity from a single model, combines analytical, empirical and finite element methods, along with sophisticated and world-leading gear and bearing contact models.

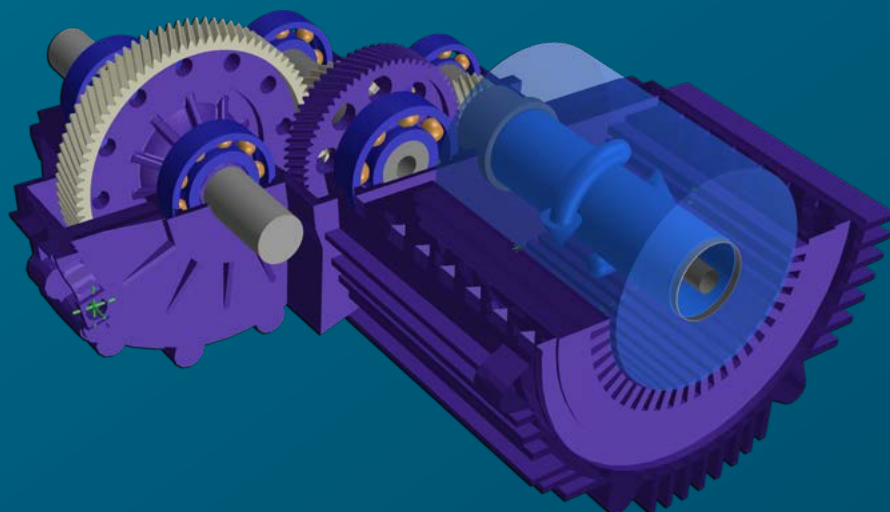

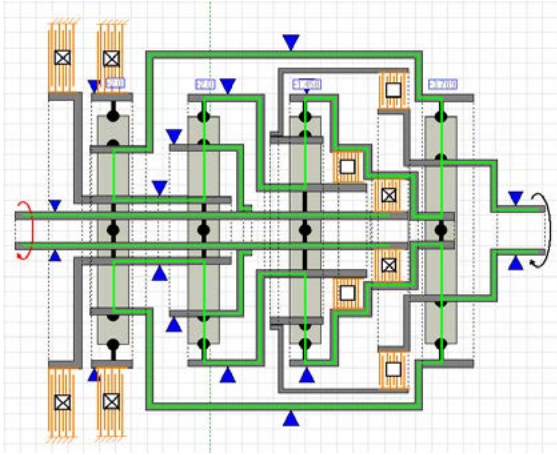

Romax Enduro

Capabilities

- Fast, parallelised and automatable structural static analysis of full electro-mechanical drive systems, including state of the art component analysis and rating
- Comprehensive duty cycle durability analysis including DIN, ISO, AGMA and other standard ratings for gear contact and bending, bearing life, shaft fatigue and spline rating
- Gear and spline macro- and micro-geometry design tools and tooth contact and root stress analysis based on a fully coupled system analysis
- Parametric studies such as full factorial, Monte Carlo, sensitivity study, genetic algorithm for optimisation, and batch operation for linking to external tools
- Multi fidelity component models ranging from conceptual to fully detailed representations to suit all stages of product development

Benefits

- Unparalleled accuracy - validated and trusted full system structural analysis, state of the art bearing stiffness models and fully coupled 6 degree-of-freedom gear contact analysis considering all meshes in the system.
- CAE-led design - flexible level of fidelity, integration with CAD, and fast simulation and post-processing for engineering insight from concept to detailed design.
- Process automation, optimisation and integration - works seamlessly with other Romax Nexus products and partner software to offer true multi-attribute optimisation via a repeatable, automatable process.

Romax Concept

Capabilities

- Fast intuitive modelling – create full system drivetrain simulation models of competing layouts in minutes, via an easy-to-use drag-and-drop interface with links to CAD.
- Early stage analysis - analyse the performance of each design concept to manage trade-offs between vehicle performance, durability, efficiency, NVH, packaging, weight, cost, etc.
- Component design within a whole system – system interactions are considered from the outset when selecting catalog components or defining gear ratios and macrogeometry.

Benefits

- Exploring a wide range of innovative layouts with the right blend of speed and accuracy allows the best design to be selected very early in the development cycle, leading to reduced cost and risk
- Flexible tool which integrates with CAD, MBD and CAE to reduce errors and time to market and streamline processes
- Empowering software enables informed engineering decisions early in the product development process

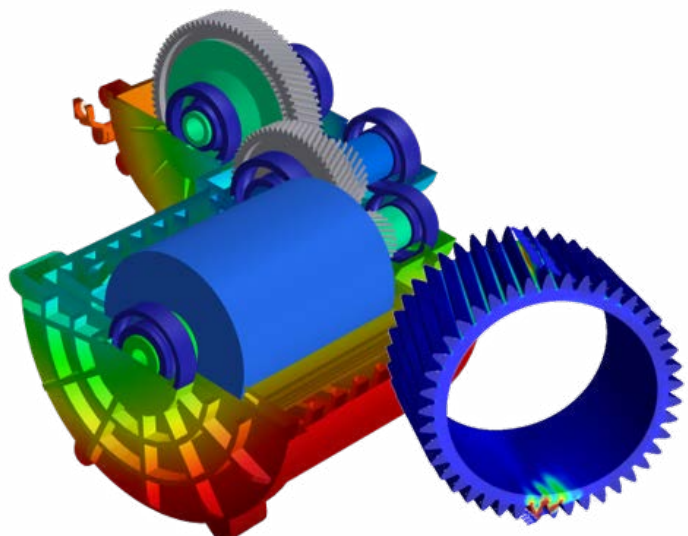

Romax Spectrum

Capabilities

- Full integrated powertrain modelling, simulation, analysis and optimisation for vibration and radiated noise
- Validated analysis to predict dynamic gear excitations, unique planetary gear simulation, and links to electromagnetic software to calculate motor forces
- Frequency domain simulation of system vibration response
- Embedded acoustic solver brings complex radiated noise simulation to the non-expert, with automated calculations to verify design targets

Benefits

- Provides the accuracy and insight required for sensitive NVH simulations, to gain engineering insight and make design improvements.
- Enables CAE-led design, through early consideration of NVH simulation early in the development process with fast, validated, intuitive simulation and analysis that allows you to make engineering decisions with confidence and minimise NVH testing and prototyping.

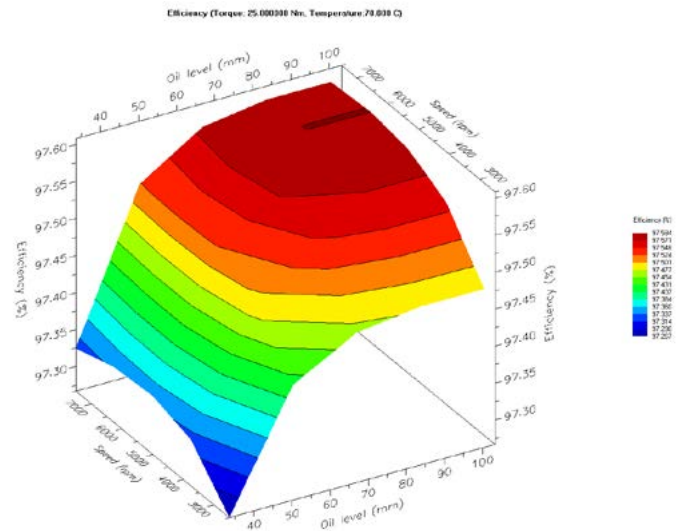
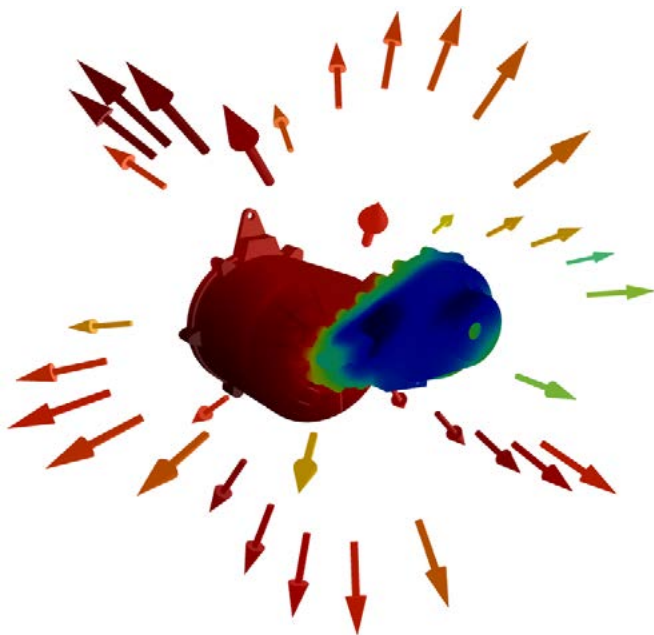

Romax Energy

Capabilities

- Comprehensive transmission power loss prediction calculation using widely-used industry methods and our own world-leading proprietary drag models
- Accurate prediction of the lubricant's effect on system efficiency, so you can select or design the optimal oil for efficiency performance
- Parametric study to investigate the impact of parameters (e.g. torque, speed, temperature, lubricant level) on system efficiency.
- Calculation of fuel consumption and CO² emissions

Benefits

- Meet efficiency targets by making reliable design improvements, using Romax Energy's comprehensive efficiency models to predict power losses
- Design and optimise components for highly efficient designs by investigating and understanding the impact of varying geometric and operational parameters on the whole system performance
- Accurately predict losses and the impact of the oil additive pack and friction modifiers on system efficiency, using our advanced tribological models and proprietary methods based on FVA345 methodology

Romax Spin

Capabilities

- Access more than 60,000 bearings from SKF, Schaeffler, Timken, JTEKT, and Nachi or model fully customisable bearings of all ball and roller types, including all external, internal dimensions and micro-geometry
- Specify ring flexibility, clearance and press fits, preload, internal clearance, mounting distortion, temperatures and other assembly and operating properties
- Accurate prediction of element and raceway stresses, rib contact, edge stress, and contact truncation, considering full system deflection, load analysis and bearing misalignments
- Advanced roller contact analysis applied to state of the art life prediction methods such as ISO/TS 16281
- Time domain simulation to analyse dynamic behaviour and avoid non-conventional failure modes such as skidding

Benefits

- Collaborative working - widely used software in the industry facilitating collaboration between suppliers and their customers, with the option to secure sensitive IP
- Advanced analysis algorithms - rapid enough to be usable at all stages of the design process yet accurate enough to capture fine details of contact stress behaviour and its effect on bearing performance and life
- Engineering insight - to design or select optimal bearings for a specific application, to understand bearing failures and identify appropriate counter-measures

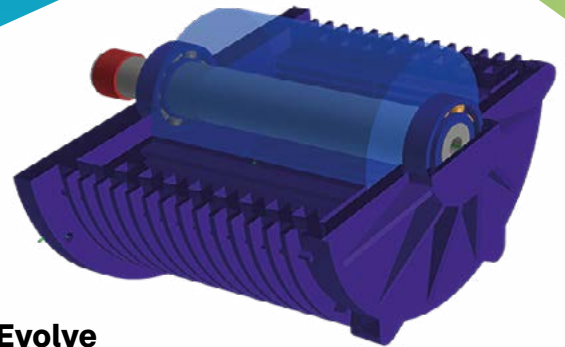
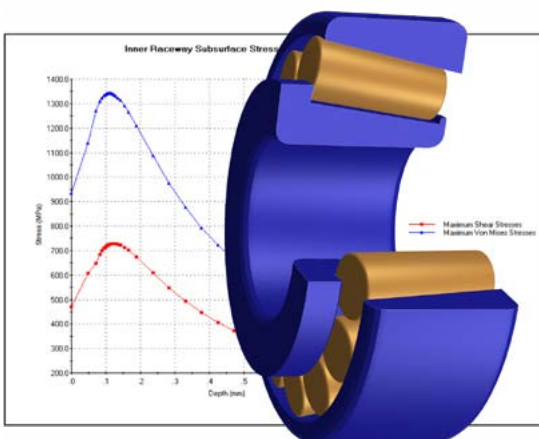

Romax Evolve

Capabilities

- Simple, parametric structural modelling, including comprehensive bearing catalogues, FE components, and links with CAD and electromagnetic FE software packages for electrical machine geometry and excitation import.
- Fast static analysis of electrical machine housing and shaft deflections.
- Evaluate bearings for durability and power loss.
- Calculate rotor-dynamic behaviour of rotor shaft system and capture the effects of UMP on static and dynamic behaviour.
- NVH analysis of electrical machine including electro-mechanical excitation sources and rotor mechanical imbalance.
- Embedded acoustic solver brings complex simulation of radiated noise to the non-expert.

Benefits

- Easy to use, application-specific tools for essential structural and NVH analysis of electrical machines, based on trusted expertise and proven capability in electro-mechanical system analysis.
- Interfaces and workflows to major electromagnetic packages to complement and enhance your existing tool chain.
- Democratised CAE-led design process for electric machines - consider structural and NVH performance from the early stages to prevent problems before they arise.

Actran

The gold standard in acoustic simulation

There is virtually no field of engineering that remains untouched by acoustic simulation technology. The reason is simple: no industry can afford to deliver a product that is too loud or does not sound right.

Actran has helped transportation, aerospace and defense, machinery and consumer goods industries to meet increasingly stringent noise regulations or to guarantee that new designs are consistent with the trademark sound of the company.

Thanks to a rich library of modeling capabilities and high-performance solvers, engineers can deal with acoustic, vibration or flow-induced noise challenges in limited timeframes. A user-friendly and highly customizable graphical user interface ensures a robust and cost-efficient integration of numerical acoustic simulation into any industrial process.

Some applications

- Powertrain, gearbox and electric engine noise prediction
- Characterization of engine air intake and exhaust systems acoustic signature
- Side mirror and climate control aero-vibro-acoustic noise analysis
- Tyre and pass-by noise assessment including acoustic treatment optimization
- Interior vehicle acoustic comfort including fully trimmed vehicle NVH performances assessment and sound package optimization
- Transmission Loss prediction of multi-layered structures considering frequency-dependent acoustic treatment effects
- Transfer path analysis and design changes impact comparison
- Fan noise assessment considering installation effects (structure vibrations, acoustic absorption, ...)
- Audio equipment integration performance assessment
- Acoustic treatment and nacelle design optimization for aircraft intake and exhaust noise
- Airframe aero-acoustic noise prediction and propagation
- Underwater noise propagation
- Prediction of vibro-acoustic fatigue due to intense random acoustic load and vibrations



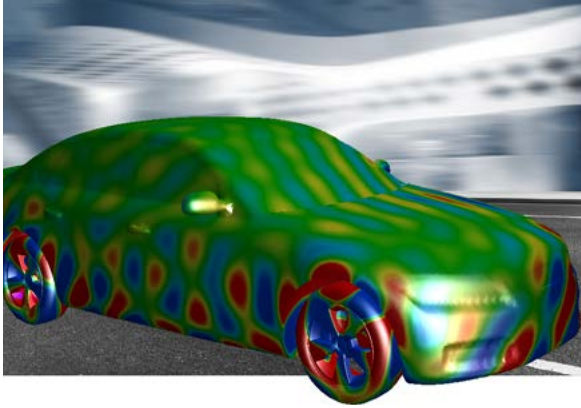

Benefits

- Predict, understand and improve product design acoustic performance while shortening optimization processes thanks to latest HPC technologies
- Seamless integration of acoustic performance assessment in existing industrial processes thanks to native file format drivers and flexible API
- Increased productivity and robustness of acoustic analysis thanks to a customizable interface

Capabilities

- GUI support for advanced results visualization including dedicated acoustic post-processing capabilities (polar charts, 3D directivity maps, contribution charts, acoustic indicators)
- Access to embedded standard acoustic indicators (ISO 3744, ISO 3745, SAE J1074 and IEC 61672-1)
- Customizable interface based on user-defined process and requirements
- Adaptive solver-based meshing technology for efficient computation and users' minimal meshing efforts
- Integrated co-simulation with multi-body time domain code Adams or CFD code scFLOW
- Co-simulation with structural analysis FEA software like MSC Nastran
- Analyze acoustic propagation and radiation in static medium or complex flow

- Simulate free field radiation with infinite elements or Adaptive Perfectly Matched Layer (APML)
- Model acoustic visco-thermal loss in small fluid domains
- Coupled vibro-acoustic analysis with direct frequency approach or modal frequency approach
- Rich structure element library: solids, shells, beams, springs, rigid bodies, multilayered composite structures etc.
- Poro-elastic element library based on the BIOT theory for modeling bulk reacting materials
- Piezo-electric element libraries for modeling active structures
- Random excitations: diffuse sound field, turbulent boundary layer, etc.
- Perform 2D, 3D and axisymmetric analysis with linear and quadratic elements
- Predict noise caused by turbulent flows retrieving aeroacoustic sources from steady or unsteady CFD results (SNGR technique, Lighthill and Möhring analogies)
- Interface with CFD codes using native CFD file format
- Low, mid and high-frequency capabilities relying on Finite Elements and Virtual SEA approaches
- Direct and iterative solvers as well as KRYLOV fast frequency response solver
- GPU acceleration for large domains, high frequency problem solving

MSC CoSim

Where multiphysics gets real

Co-simulation provides engineers with a unique, more complete & holistic performance insight by coupling together multiple simulation disciplines. Everything from acoustics to multibody dynamics (MBD), to CFD, to structural analysis, and explicit crash dynamics can be connected together in MSC. Depending on the type of analysis, engineers can use MSC solutions in two ways – Co-Simulation (applying multiple physics to the model simultaneously) or Chained Simulation (passing load case results from one analysis to the next).

MSC CoSim engine

The MSC CoSim engine has been developed in order to provide a co-simulation interface for the direct coupling of different solvers/disciplines with a multi-physics framework. This first version, readily available today, enables engineers to set up co-simulation models between Adams, Marc and scFLOW.

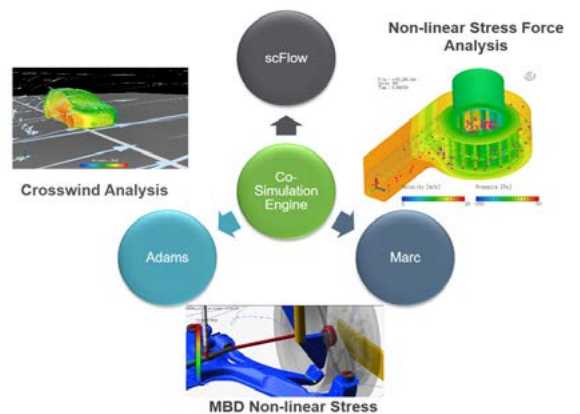

Other open co-simulation solutions

Besides the CoSim engine, MSC also supports a list of other co-simulation methodologies, including the Functional Mock-up Interface (FMI), Adams Marc Co-Simulation Interface (ACSI) and so on.

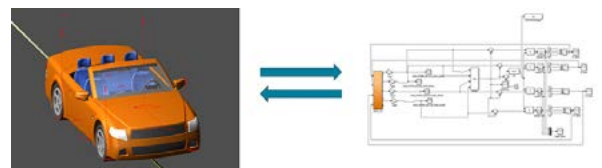

Chained simulation

Chained simulation allows CAE engineers from different departments to integrate multiple disciplines sequentially and improve the overall simulation accuracy. For example, passing the road loads data from an Adams Full Vehicle model to the downstream MSC Nastran model for the stress & durability analyses.



Cradle CFD

Multiphysics focused computational fluid dynamics software

Cradle CFD offers a practical, state-of-the-art computational fluid dynamics, CFD, simulation and visualization software solution. Embracing remarkable processing speed, refined technology, and proven practicality verified by high user satisfaction, it has been in use for diverse applications, such as Automotive, Aerospace, Electronics, Building and Architecture, Civil Engineering, Fans, Machinery, and Marine developments, to solve thermal and fluid problems. Incorporating Multiphysics co-simulation and chained simulation capabilities to achieve couplings with Structural, Acoustic, Electromagnetic, Mechanical, One-Dimensional, Optimization, Thermal Environment, 3D CAD and other analysis tools that allow users to efficiently solve engineering problems spanning multiple disciplines. The powerful award-winning postprocessing capabilities to generate visually powerful simulation graphics to easily convey simulation data, Cradle CFD enables users with any skill level to process advanced simulations and gain valuable insights into their designs. Cradle CFD solution consists of the following products:

scFLOW

scFLOW is a next-generation CFD tool that uses unstructured mesh to accurately represent complicated geometry. With a streamlined workflow, the Preprocessor aids users to generate high-quality polyhedral mesh elements and construct complicated models and the Solver ensures more stability and speed, scFLOW is capable of solving aerospace and automotive aerodynamics, performance of fans, pumps and other rotating equipment, design problems of electronic devices, multiphase phenomena, marine propeller cavitation, and varied problems effectively. Through co-simulation and chained simulations coupled with MSC Software's Marc, MSC Nastran, Adams and Actran, more realistic coupling and multidisciplinary analyses with fluid, structure, acoustics, and multibody dynamics can be achieved.

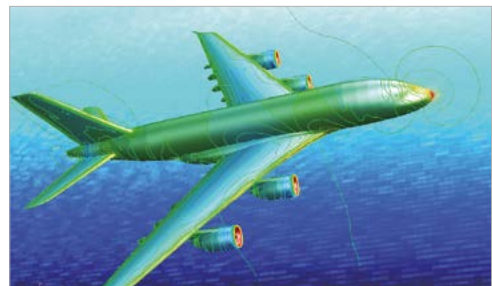
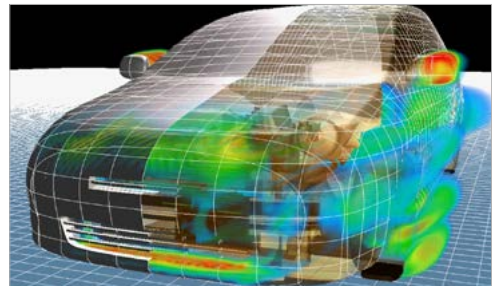

scSTREAM

scSTREAM is a general-purpose CFD tool that uses Cartesian or cylindrical structured mesh to enable easy mesh generation and high-speed simulations to be performed in a fraction of the time of other solutions. Due to the meshing nature and analysis system that enables large-scale calculation, scSTREAM excels at processing extensive simulations, where users are required to solve engineering problems such as thermal problems of electronic devices and indoor environment, wind flow, and heat island phenomena.

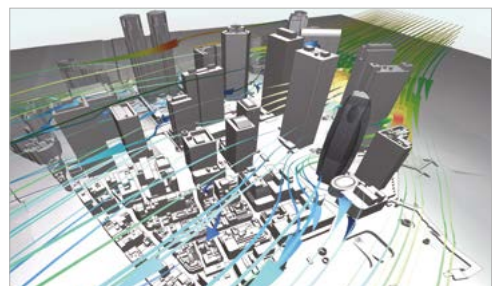
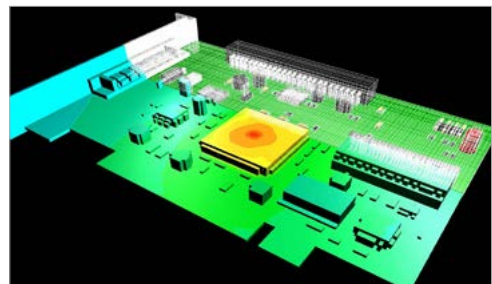



scPOST

scPOST is a comprehensive and versatile data visualization software empowering novice and expert users to instantly create a rich view of design performance.

It has capability for a sharable light-weight format that supports virtual reality for a more immersive data visualization experience.

In addition to fluid dynamics results, it also supports other simulation results from Actran, Adams, MSC Nastran and Marc all in one visualization solution.

HeatDesigner

HeatDesigner is a structured (Cartesian) mesh thermal fluid analysis software specially designed for electronics cooling thermal analysis. It uses core technology from Software Cradle's scSTREAM general purpose structured mesh thermal-fluid software product.

HeatDesigner's performance is optimized for applications that do not require precise reproduction of fine geometrical curvature to predict an accurate flow field. However,

HeatDesigner is capable of accommodating meshes with over a hundred million elements enabling it to capture fine geometrical details. Like scSTREAM, the major advantages of HeatDesigner are fast calculations times and low memory consumption.

Capabilities

- Import native data from major 3D CAD software as well as most generalized intermediate data formats (Parasolid XT, STEP, and others)
- Capable of solving compressible (density-based solver) and incompressible (pressure-based solver) flows
- Account for thermal radiation effects by VF and FLUX methods
- Discontinuous mesh, overset mesh, moving object functions to enable evaluating object rotations and motions, as well as flow and heat generated as a result
- Able to evaluate 6 degree-of-freedom motion, where a rigid body is passively translated or rotated by fluid force
- Free surface function to calculate interface geometry between gas and liquid
- Perform free surface analysis to evaluate boiling and condensation, heat conduction, latent heat, and gas-liquid phase changes
- Analyze phase changes between liquid and solid, solidification, melting, interaction between flow, and heat transfer resulting from latent heat
- Calculate humidity and dew condensation caused by temperature changes and evaporation/transferring moisture within solid
- Assess cavitation and possible erosion on propeller rotating at high speed underwater
- Perform multiphase analysis using DEM (Discrete Element Method) that enables coupling of fluid and flow analysis of particles
- Simulate particle behavior affected by diameter size, density, falling speed, and interaction between particles and fluids
- Account for liquefaction at adhering on the wall surface
- Consider external force and effects of an electrostatic field on charged particles
- Import wiring pattern such as Gerber data generated by electronic CAD to generate a model
- Convert results on temperature changes acquired by transient heat resistance measurement into structure function (thermal resistance – heat capacity characteristics) to accurately generate a thermal model
- Illuminance analysis to evaluate and consider directivity effects on the brightness of objects, where natural daylight and artificial lighting is cast
- Refer to climate data (ASHRAE and NEDO) to analyze solar radiation, where the position of the Sun is automatically calculated by longitude, latitude and date
- Thermoregulation model (JOS) to analyze temperature and humidity changes of the human body and surrounding environment
- Estimate comfort level (PMV and SET*), degree of heat stress (WGBT), and ventilation (SVE)
- Mapping function minimizes calculation load by applying a wide range of its surrounding area as boundary conditions
- CradleViewer, Light-weight viewer application with support for virtual-reality that allow users to easily access and share simulation data
- Rich set of automation API that allows users to highly automate workflows, democratizing Cradle CFD solutions to non-expert users
- Award-winning, powerful visualization postprocessing capabilities

Digmat

The nonlinear multi-scale material and structure modeling platform

Digmat enables engineers to perform both micro- and macro-scale analyses of composites, predicting their performance and calculating their mechanical, thermal and electrical properties. A large variety of composite materials, including those made from thermoplastic and thermoset polymers, and elastomers, can be effectively modeled with Digmat.

Digmat composites modeling technology relies on micromechanical approaches to accurately predict the behavior of multi-phase material. Digmat offers optimized solutions to bridge the gap between manufacturing process, material design and structural FEA. Outputs of the manufacturing simulation, fiber orientation, residual stresses, weldlines, void density are used by Digmat to compute the exact non-linear strain-rate dependent material performance of composite materials. NVH, stiffness, crash, durability, creep are examples of analysis where Digmat solutions can be applied.

With Digmat as part of your CAE suite, your product development becomes more predictive, enabling you to optimize composite structure design with confidence saving both time and resources.

Digmat modules:

- Digmat-MF: For a fast & accurate prediction of the nonlinear behavior of multi-phase materials using Mean-Field homogenization technology.
- Digmat-FE: For an accurate prediction of the local/global nonlinear behavior of multiphase materials using FEA of realistic Representative Volume Element (RVE).
- Digmat-MX: For the preparation, storage, retrieval and secure exchange of Digmat material models between material suppliers and users.
- Digmat-CAE: Interfaces to process and structural FEA codes for an accurate prediction of composite materials and reinforced plastics parts performance using nonlinear multi-scale modeling approach.
- Digmat-MAP: For an efficient mapping of scalar & tensorial data between dissimilar shell and solid FE meshes.
- Digmat-HC: Easy and efficient solution for the design of honeycomb sandwich panels.
- Digmat-RP: An integrative simulation environment dedicated to integration of Digmat material model inside your FEA model for short fiber reinforced plastic components and systems simulation.
- Digmat-VA: Integrated solution for the computation of virtual allowables
- Digmat-AM: Process simulation solution for polymer additive manufacturing

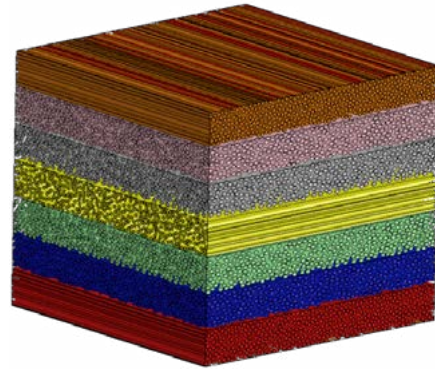
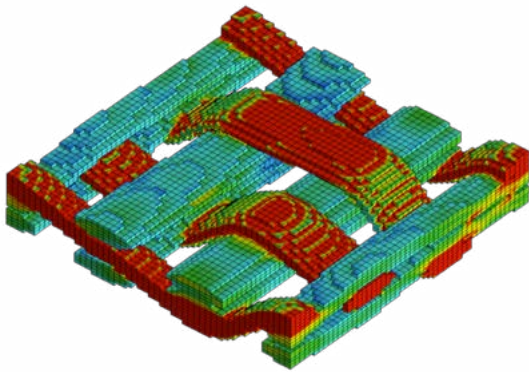

Capabilities

- Holistic approach to model composite materials (materials, physics, CAE technology)
- Multi-scale modeling from the microscopic to the macroscopic scale, with representative volume elements, homogenization technology
- Material exchange platform to prepare, store, retrieve and securely exchange Digimat material models between material experts and structural engineers
- Virtual testing of composite materials with flexible loading definitions – monotonic and cyclic
- Support for broad range of composite materials, including fiber reinforced plastics, hard metals, ceramics, nano, and sandwich panels
- Complex material morphologies (multi-phase, multi-layer)
- Support for linear/nonlinear, temperature & strain rate dependent behaviors
- Analysis of failure, creep, and fatigue
- Interfaces to all major FEA and processing simulation software

Benefits

- Improve fidelity in simulations through better material modeling
- Characterize multi-phase composite materials with ease
- Improve accuracy by bridging the gap between FEA and processing simulation
- Improve communication and standardize material library to reduce errors

Easy5

Advanced controls and systems simulation

Engineering aircraft, vehicles, agricultural equipment, and other complex systems requires a systems-engineering approach in which not only the components and sub-systems but the entire system as a whole is tested. Traditional 'build and test' methodologies are time-consuming and expensive; and now more than ever, every industry is challenged to meet the conflicting requirements of increasing innovation while reducing cost and time to market.

Easy5 provides accurate, reliable multi-domain modeling and 1d simulation of dynamic physical systems. Using Easy5, some of the most respected companies in the world are evaluating system level performance with CAE to reduce physical prototypes, cut cost, and accelerate their product development process.

Dynamic systems; those systems whose behavior as a function of time is important, are typically defined using first-order differential (or difference) equations. Easy5 simplifies the construction and analysis of such systems by means of a graphical, schematic-based application, offering a comprehensive set of pre-packaged "components", stored in application-specific libraries, to simplify the assembly and simulation of such systems. Systems engineers work within a familiar schematic drawing environment to add and specify simple, yet complex, connections between components in an intuitive, simple-to-use, multi-level hierarchical modeling environment.

Typical applications of Easy5 include control systems, hydraulics (including thermal effects), pneumatics, gaseous flow, thermal, electrical, mechanical, refrigeration, environment control, lubrication or fuel systems, and sampled-data/discrete-time behavior.

Easy5 has 5 Application Package Libraries:

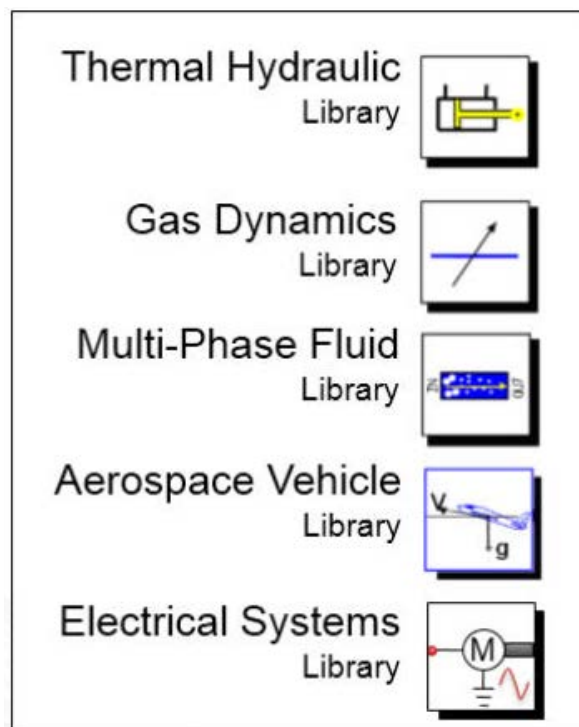

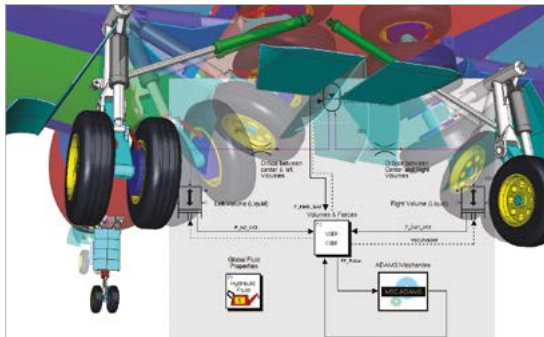

Capabilities

- Assemble models easily from hundreds of pre-built system components
- Easy to use schematic based 1d system-level modeling, simulation and analysis
- Complete system virtual prototyping by linking Easy5 to other MSC applications
- 64-bit support for Windows and Linux
- Integration with SimManager for easy sharing of models and results (Windows only)
- Customizable libraries of components
- Easy to use GUI with Windows style functionalities
- Integration with other CAE software packages like Adams, MSC Nastran and Simulink®
- FMI (Functional Mockup Interface) Support for easier co-simulation

Benefits

- Asses complex multi-domain systems quickly and accurately
- Improve products early in the design process
- Understand problems and design countermeasures effectively
- Reduce CAE cost with shareable libraries
- Improve CAE effectiveness by integrating with other tools

Marc

Advanced nonlinear simulation solution

Marc is a powerful, general-purpose, nonlinear finite element analysis solution to accurately simulate the response of your products under static, dynamic and multi-physics loading scenarios. Marc's versatility in modeling nonlinear material behaviors and transient environmental conditions makes it ideal to solve your complex design problems.

- Nonlinear and multiphysics solution schemes: Solve problems spanning the entire product lifespan, including manufacturing process simulation, design performance analysis, service load performance and failure analysis with robust nonlinear algorithms and multiphysics capabilities that include coupled thermomechanical analysis, electromagnetics, piezoelectric analysis, electrical-thermal-mechanical, electrostatics and magnetostatics coupled with structural response and more.
- Nonlinear materials: Choose from an extensive library of metallic and non-metallic material models, along with a library of nearly 200 elements for structural, thermal, multiphysics and fluid analyses.
- Failure and damage analysis: Investigate damage and failure using models suited for several material classes, including ductile, brittle, composites, elastomers, and concrete. Study crack propagation to avoid catastrophic structural failures.
- Contact analysis: Easily set up a contact model, analyze and visualize the ever-changing component interaction. Account for friction and plasticity generated heating in a coupled analysis.
- Automatic remeshing: Use local and global adaptive remeshing capabilities to overcome problems due to high stress gradients and/or large element distortions.
- Parallel processing: Achieve higher productivity with the time tested parallel analysis capabilities. Take complete advantage of the multi-core processors and the GPUs available on their systems, to achieve higher performance.
- Integrated pre-/post-processing: Create and analyze complex models with an integrated user interface designed expressly for nonlinear analysis. Customize the application with Python scripting language to automate repetitive tasks across the entire simulation process.

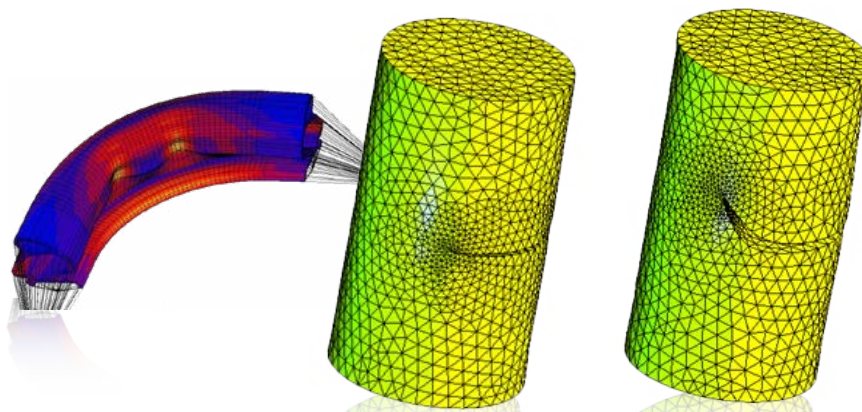

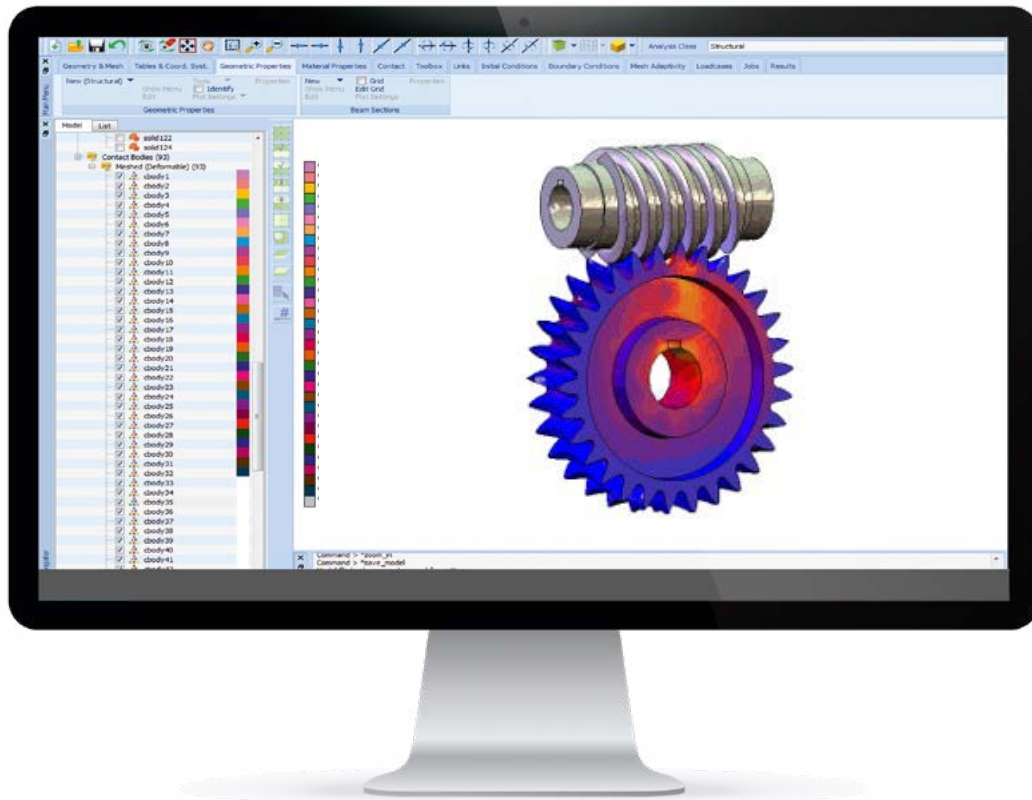

Capabilities

- Advanced nonlinear materials
- Industry proven contact to accurately simulate product performance and manufacturing
- Coupled solutions of nonlinear structural, thermal, electromagnetics.
- Advanced heat transfer analysis capabilities
- Special purpose material models including Shape Memory Alloy and Solder models
- Comprehensive connector and fastener models to simulate commonly found connections
- State-of-the-art iterative solvers and parallel processing on shared and distributed memory machines
- Automated remeshing and adaptive meshing to increase solution robustness and accuracy
- Advanced damage and fatigue analysis of metals and composite structures
- Predict crack initiation and propagation under realistic load conditions

Benefits

- Robust solver technology that greatly enhances the value of nonlinear solutions encountered in many industries
- Shorten the design optimization process, while improving design and product performance through integrated simulation
- Reliable analysis capabilities to reduce product design, development, manufacturing and warranty costs



Simufact

Virtual manufacturing for metalworking industry

Simufact is a leading FEA based simulation solution for metal forming, joining, welding and metal-based additive manufacturing. With the ability to simulate the entire manufacturing process chain, starting from blanking, shearing of wires or billets, to multi-stage forming, punching, trimming, and heat treatment followed by joining operations, welding and structural analysis, Simufact helps optimize the manufacturing processes, and reduce costs and time-to-market, while improving product quality.

Simufact Forming

Simufact Forming is an established software solution for the simulation of forming manufacturing processes. The software covers all essential areas of forming technology: forging, cold forming, sheet metal forming, all rolling processes, open die forging and mechanical joining, to name only the most important processes. Simufact Forming provides support in microstructure simulation, calculation of die load, material flow and prediction of material properties in the course of conventional and inductive heat treatment. Furthermore, thermo-mechanical joining methods of pressure welding are also supported.

Simufact Welding

Simufact Welding is used to model and calculate a wide range of thermal joining processes by means of the welding structure simulation under consideration of weld sequence and clamping. Processes such as arc welding, laser beam welding, electron beam welding, brazing as well as resistance spot welding can be modeled in Simufact Welding. A new field of application is the simulation of deposition welding and modeling of the generative manufacturing process 'Direct Energy Deposition' (DED). In addition, Simufact Welding can be used to model the heat treatment, different variants for cooling and unclamping as well as the mechanical load on welded structures. Simufact Welding uses a scalable calculation approach with which the calculation speed and accuracy can be controlled as required.

Simufact Additive

Simufact Additive is a scalable software solution for the simulation of metal-based additive manufacturing processes which focuses on powder bed melting processes. With the macroscopic approach, users obtain simulation results within minutes that predict the tendency of stresses and distortions. Furthermore, thermal or thermo-mechanical calculations can be performed to obtain precise results which consider the temperature distribution during the process.

Simufact Additive is a software solution designed to predict and compensate for distortion, residual stress and temperature distribution throughout the printing, heat treatment, cutting and HIP processes virtually before the part is manufactured by the 3D metal printer in reality.

Additional modules are available for all Simufact software solutions to help with microstructure calculations, faster performance, additional CAD import interfaces, customization, and access to material databases.

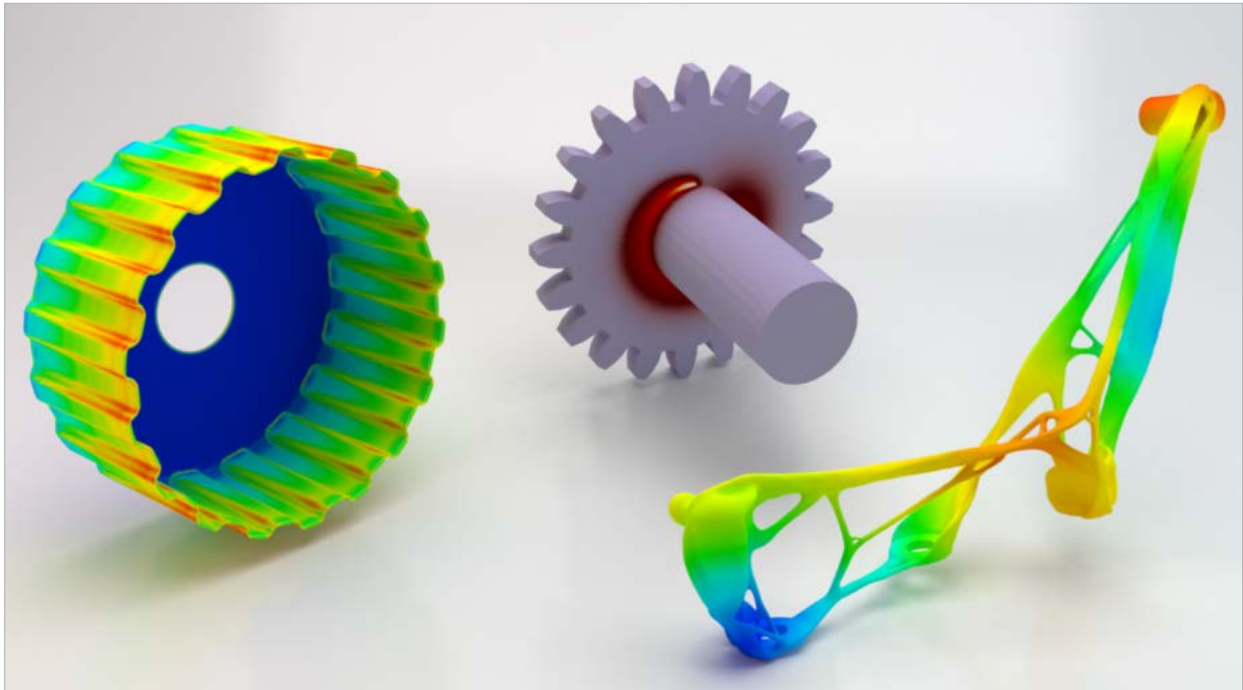

Capabilities

- Best-in-class solution for manufacturing processes
 - Forming applications
 - Joining applications
 - 3D-metal-printing applications
- Pre- and post-processing environment dedicated to manufacturing processes
- Accurate material description
- Prediction of part properties during the manufacturing process chain
- Open architecture
- Strong solver able to solve simple to the most advanced manufacturing problems
- Integrates the most advanced technologies for best accuracy

Benefits

- Best-in-class result accuracy at highest speed & stability
- Scalable solutions
- Cost optimized
- All relevant manufacturing process stages with full interoperability
- Simple process-oriented setup of the process
- Supported by a team of manufacturing experts
- Developing an efficient forming method in a short span of time without blocking the machine for testing
- React fast and better and flexible on new demands
- Controlling temperature and machine force

MSC Nastran

Multidisciplinary structural analysis

MSC Nastran is the world's first FEA structural analysis code that is still the gold standard in a wide range of industries and applications today. It is a multidisciplinary structural analysis application used by engineers to perform static, dynamic, and thermal analysis across the linear and nonlinear domains, complemented with automated structural optimization and award winning embedded fatigue analysis technologies, all enabled by high performance computing. MSC Nastran is the most trusted solution in the industry. MSC Nastran's predictions are the most consistent and accurate in the industry. Engineers get "right results every time" using MSC Nastran.

Manufacturers leverage MSC Nastran's unique multidisciplinary approach to structural analysis at various points in the product development process. MSC Nastran may be used to:

- Virtually prototype early in the design process, saving costs traditionally associated with physical prototyping
- Remedy structural issues that may occur during a product's service, reducing downtime and costs
- Optimize the performance of existing designs or develop unique product differentiators, leading to industry advantages over competitors.

MSC Nastran is based on sophisticated numerical methods, the most prominent being the Finite Element Method. Nonlinear FE problems may be solved either with built-in implicit or explicit numerical techniques.

MSC Nastran advantages

- Multidisciplinary Structural Analysis: To build up a comprehensive level of engineering analysis capability, multiple software solutions must be acquired, and users must be trained with each new tool. MSC Nastran features multiple analysis disciplines, enabling customers with one structural analysis solution for a wide variety of engineering problems.
- Structural Assembly Modeling: One structural member is rarely analyzed independently. Structural systems consist of numerous components, and must be analyzed as a whole. MSC Nastran features a number of methods to join multiple components for system level structural analysis.
- Automated Structural Optimization: Design optimization is a critical element in product development, but is often very iterative and requires a great deal of manual effort. MSC Nastran includes optimization algorithms that automatically seek optimal configurations in an allowed design space.

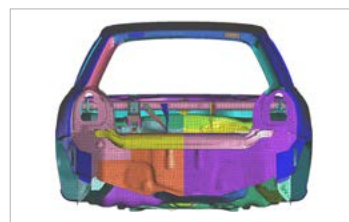
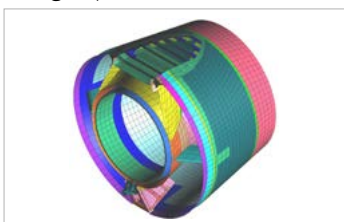

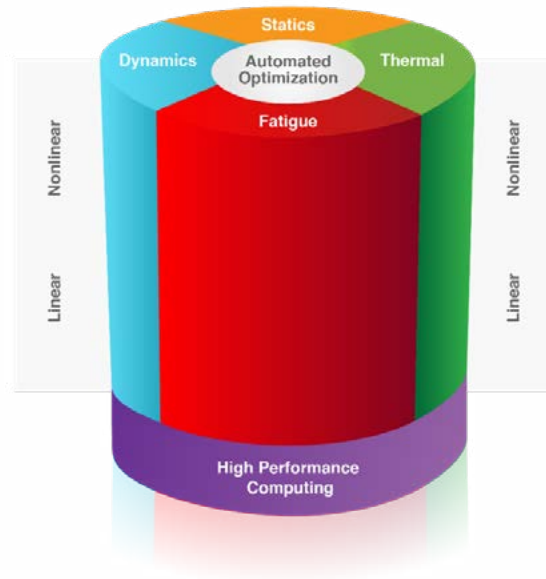

Benefits

Multidisciplinary structural analysis

- Use one platform to perform linear or nonlinear analysis for the following disciplines: static, dynamic (NVH and Acoustics included), thermal, and buckling, and reduce the dependency on multiple structural analysis programs from various vendors
- Perform fatigue analysis with embedded fatigue technologies and reduce the time usually associated with fatigue life determination
- Assess the behavior of advanced composites and fiber reinforced plastics with built in Progressive Failure Analysis and User Defined Services for Mean-field Homogenization coupling with Digimat

Structural assembly modeling

- Expedite meshing with Permanent Glue, enabling you to connect incongruent meshes that would traditionally require time consuming mesh transitions
- Save time constructing assemblies that consists of welds or fasteners via specialized connector elements
- Speed up the re-analysis of large assemblies by constructing Superelements, and optionally, share Superelements with other manufacturers while concealing confidential design information
- Perform contact analysis and determine contact stresses and contact regions in multi-component designs

Automated structural optimization

- Optimize for stress, mass, fatigue, etc. while varying design variables such as material properties, geometric dimensions, loads, etc.
- Enhance the shape or profile of structural members with shape optimization
- Find optimal composite laminate ply thicknesses with topometry optimization
- Determine optimal bead or stamp patterns for sheet metal parts with topography optimization
- Remove excess and unnecessary volume with topology optimization
- Simultaneously optimize multiple models across disciplines with Multi Model Optimization

Dytran

Explicit dynamics and fluid structure interaction

Dytran is an explicit finite element analysis (FEA) solution to simulate short-duration events like impact and crash, and to analyze the complex nonlinear behavior that structures undergo during these events. Dytran enables engineers to study the structural integrity of designs to ensure that final products meet customer safety, reliability, and regulatory requirements.

Dytran delivers structural, material flow and coupled FSI analysis capabilities in a single package. Using a unique coupling feature that enables integrated analysis of structural components with fluids and highly deformed materials in one continuous simulation, Dytran provides realistic solution to complex problems.

- **Transient structural analysis:** Using explicit solver technology, Dytran provides faster solution to large, complex transient dynamic problems. Users can use from a wide variety of elements that include solid, shell, beam, membrane, connectors and rigid elements, to model the structures.
- **Nonlinear materials:** Select from a wide range of material models to model the nonlinear response and failure. The available material models include linear elasticity, yield criteria, equations of state, failure and spall models, explosive burn models and composite materials to name a few.
- **Contact analysis:** Model interaction between multiple parts and assemblies with robust contact analysis capability. The interaction may include frictionless contact, sliding with frictional effects and separation. Single surface contact can also be used to model buckling of structures where structures may fold onto themselves.
- **Fluid-structure interaction:** Analyze fluid behavior and its effects on structural response in a single model with the help of a combination of Lagrangian and Eulerian solvers in Dytran. Interaction between the fluids and structures is achieved through a coupling surface created on structures.
- **High performance computing:** Achieve higher productivity by taking advantage of the latest numerical methods and high performance computer hardware. Analyses can be run on a broad range of machines including desktop computers to supercomputers. Users can also benefit from the parallel processing capabilities to achieve faster solutions.

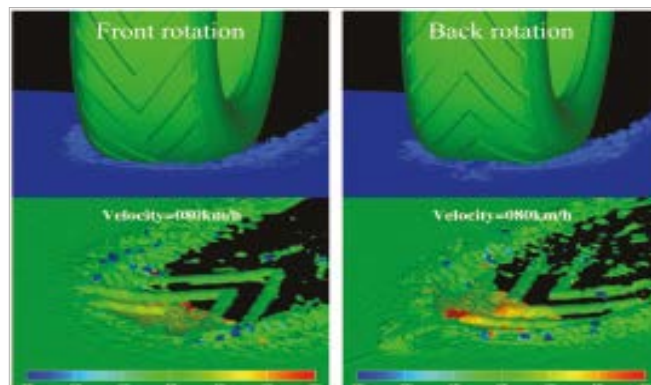

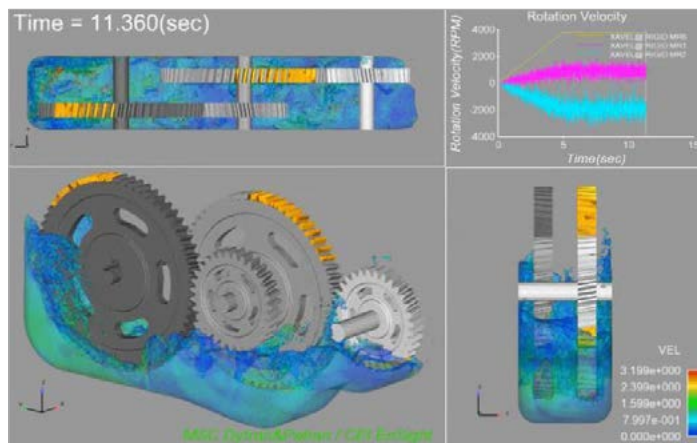

Capabilities

- Advanced, explicit nonlinear solver technology for simulating and analyzing extreme, short duration dynamic events.
- Robust and efficient three-dimensional contact and coupling algorithms using Lagrangian finite element method for structural analyses and Eulerian finite volume method for fluids and multi-material flow analyses.
- Complete finite element model library that includes beams, shells, solids, springs, and dampers with large displacement formulation.
- Full range of nonlinear material models for metals, composites, soils, foam rubber, liquids, and gases.
- Distributed Memory Parallel (DMP) support for Eulerian solver and coupling surface computation

Benefits

- Minimize the costs of physical prototyping and eliminate redundant test cycles through Dytran's streamlined modeling flow and most advanced fluid-structure interaction (FSI) simulation capabilities.
- Quickly obtain detailed insight into the nonlinear, dynamic behavior of real-world problems that cannot be easily solved with other simulation tools.
- Model complex scenarios and perform “what-if” analyses earlier in the design cycle within a single analysis package and simulation environment.
- Apply results from Dytran to improve the quality of your products and minimize the probability of failures and costly redesigns.



**VOLUME
GRAPHICS**

part of Hexagon

Volume Graphics

Comprehensive real-world data as a basis for MSC simulation

Volume Graphics enables its customers to keep the quality high by getting full insight into their products—from design to serial production. Founded in 1997 and headquartered in Germany, the company has more than 20 years of experience in the development of software for non-destructive testing based on industrial computed tomography (CT). Since 2020, Volume Graphics has been part of Hexagon.

Volume Graphics applications such as the comprehensive CT analysis software VGSTUDIO MAX cover all needs related to metrology, defect detection and assessment, material properties, whether a customer is using the all-encompassing technology of CT or other 3D data formats such as point cloud, mesh, and CAD. Thanks to its modular concept, VGSTUDIO MAX evolves with the needs of the customer. And with VGINLINE, a ready-to-use framework that relies on the advanced capabilities of VGSTUDIO MAX, customers can semi- or fully automate their quality control process.

CT data provides the basis for the insightful results the Volume Graphics software delivers, as CT non-destructively reveals every aspect of an object. Because CT reconstruction produces a complete representation of an object in 3D from a large number of 2D X-ray images, software such as VGSTUDIO MAX allows the user to draw conclusions on the external and internal structures of the object and its material properties. Thus, the user gets answers to more complex questions. Moreover, the technology of CT is uniquely positioned to fuel simulations with real-world data. In the end, customers can improve their simulations and validate results—all by using CT data analyzed with Volume Graphics software.

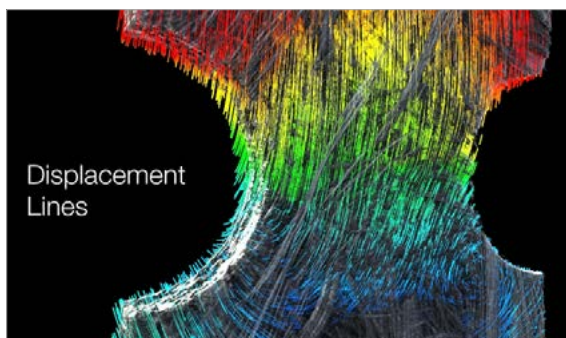

The **Digital Volume Correlation Module** offers superior support for finding damage in materials using a voxel-based before-after comparison, making it possible to easily export strain tensors with respect to your FEM mesh to validate your FEM simulations.

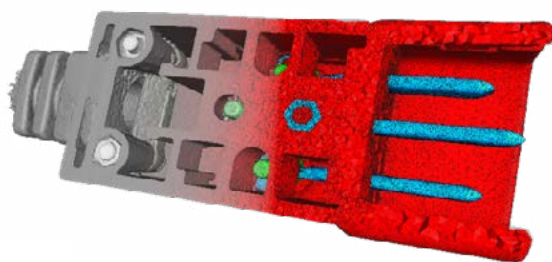

Use the **Volume Meshing Module** to create accurate and high-quality tetrahedral volume meshes from your CT scans which you can then use for mechanical, fluid, thermal, electrical, and other FEM simulations.

Learn more at: www.volumegraphics.com

Sinda

Advanced thermal simulation solution

Sinda is a thermal analyzer that has been extensively used in a wide range of successful space programs including Astra, ERS 1-2, Gomos, Mars Express, Silex, Soho, across multiple industries including Aerospace, Automotive, and Electronics.

Sinda goes beyond other solutions by also providing a powerful thermal programming language, enabling engineers to construct complex thermal scenarios that would otherwise be difficult or impossible with other analyzers. It uses a conductor-capacitor network representation approach to thermal analysis that offers numerous benefits when solving thermal problems. Sinda goes beyond other solutions by also providing a powerful thermal programming language, enabling engineers to construct complex thermal scenarios that would otherwise be difficult or impossible with other analyzers. The flexibility of Sinda is extended even more with integration to a wide number of thermal modeling tools including Patran, SimXpert, SindaRad, THERMICA, Thermal Studio and Visio.

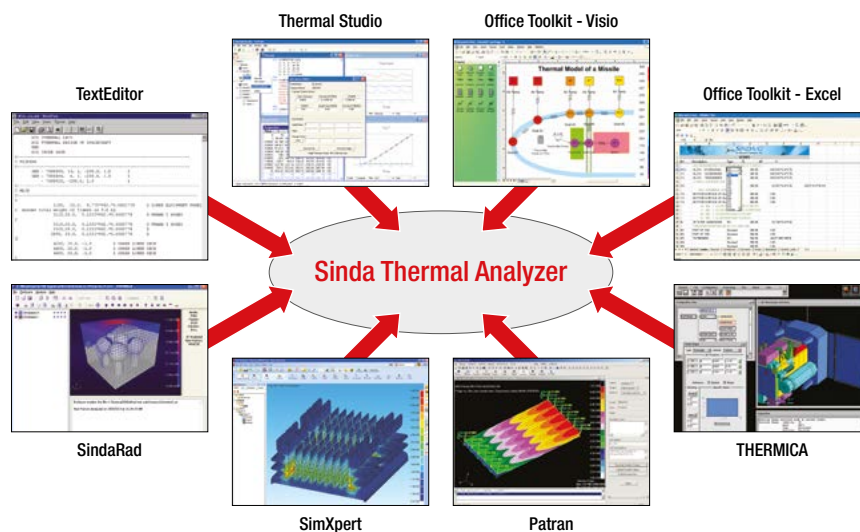

Capabilities

- Use an intuitive RC network approach to build thermal models
- Set up advanced thermal problems involving nonlinear materials, radiation, and other complex boundary conditions
- Integrate with a variety of pre-post processors and radiation codes to utilize existing models, reduce learning time, and increase total project cohesion
- Provide unique programming logic to analyze any number of "what-if" situations
- Easily set up parametric analysis such as sensitivity, optimization, and test correlation to increase understanding of thermal consequences to design changes
- Use a proven tool in the aerospace and high-tech industries with a quarter century track record

- Select from 25 steady state and transient solvers to converge almost any solution quickly and accurately
- Includes Thermal Studio; a Windows based GUI for creating and running models and reviewing the results in tabular reports of x-y plots
- Integrate into Patran, THERMICA, Visio or Excel

Benefits

- Model terrestrial heating for solar loads on Airplanes, Automobiles, Solar Power Plants, Civilian Structures, and more
- Analyze ablation of thermal electric devices and heat pipes
- Improve product life with optimized cooling
- Enhance user comfort and safety with better thermal management

CAEfatigue

FE-based random response and durability simulation

CAEfatigue is a FE-based random response and fatigue solver that has rapidly become the analysis tool of choice for random response and fatigue life calculations for static or dynamic problems in both the time domain and frequency domain. Testing against repeated loading cycles, sometimes millions of times over, is often too expensive and time consuming to be practical. Finite element analysis programs can tell you where stress “hot spots” exist, but on their own cannot tell you whether those hot spots are critical areas for fatigue failure, when fatigue might become a problem and how to possibly fix those problems. Many manufacturers simply accept long prototype-development cycles, overweight components, unpredictable warranty claims, and loss of customer confidence. CAEfatigue enables durability engineers to quickly and accurately predict how long products will last under any combination of time-dependent or frequency-dependent loading conditions. Benefits include reduced prototype testing, fewer product recalls, lower warranty costs, and increased confidence that your product designs will pass required test schedules.

CAEfatigue also offer the User the ability to calculate random response for displacements, velocities, accelerations, forces and to use that ability to detect “rattle” conditions (i.e. if parts might hit under random loading), to transfer or cascade loading from one area of the model to another and to even develop less complicated surrogate loading that can replace multi inputs with single inputs, which is especially useful for testing components and parts. The advanced random response and life estimation capability of CAEfatigue allows users to perform comprehensive random response and fatigue analysis with the same FE model setup that is used for stress analysis. The environment seamlessly enables CAE, dynamic analysis, and durability to be managed in one user friendly interface.

Modules

CAEfatigue is packaged in 3 configurations that you can choose from based on your analysis needs.

- CAEfatigue **TIME**: This package is used to calculate static and dynamic time domain durability and fatigue damage using results from Nastran, Ansys and/or Abaqus. This package includes a Graphical User Interface (GUI) for Microsoft Windows™. This package also includes the Loads Scheduler toolset for graphically developing time-based input loading from block loading, deterministic waves (i.e. sine, square, triangle, sawtooth), sine sweeps, XY pairs, etc.
- CAEfatigue **FREQUENCY**: This package includes TIME and is used to calculate static and dynamic frequency domain random response and fatigue damage from Base Shake (single input) or Multi input loading using system properties (transfer functions) from a variety of different solvers (e.g. Nastran, Abaqus, Ansys). This package also includes the TIME2PSD toolset for converting time domain data into frequency domain PSD matrix file.
- CAEfatigue **PREMIUM**: This package includes FREQUENCY and is used to calculate time and frequency domain random response and fatigue damage. It also includes advanced random outputs like displacements, velocities, accelerations and forces, allows for the use of standalone deterministic loading or mixed deterministic loading with random loading and also allows for the calculation of surrogate loads and the use of spot / seam / User welds in the time domain and frequency domain.

The product is available within MSC ONE, as a standalone software or within MSC Nastran.

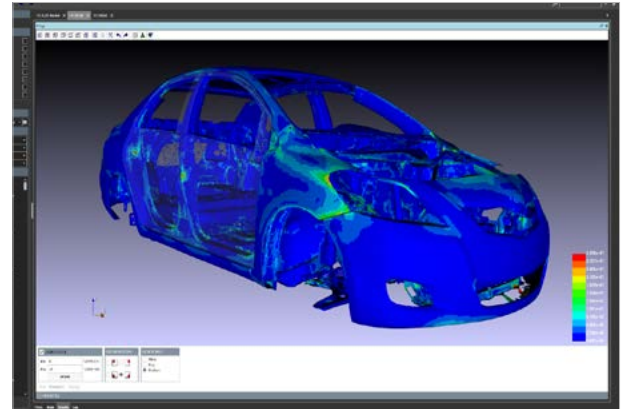
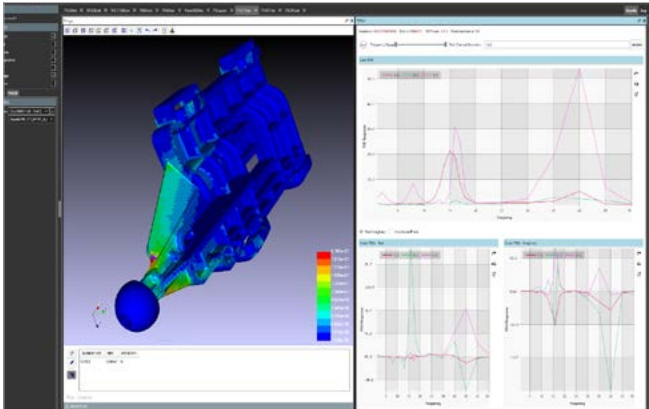

Capabilities

- Processing times are super-fast due to advanced “Running Sum Technology” with no limits on the size of the model being analyzed or loading being applied.
- For a frequency domain analysis, the software can use any number of random loads with or without deterministic loads (i.e. random only, sine-on-random, sine only, sine sweep, harmonic sines, etc.). The software can be used to detect collisions between parts under random loading (Rattle detection), can be used to cascade input loads to other parts for further analysis and can be used to optimize loading to reduce complexity; i.e. reduce a multiple input PSD loading to a single input PSD loading or even a single sine wave.
- For a time domain analysis, the software can do quasi static, full transient or use modal participation factors. Will also support non-linear stress inputs from Nastran and Marc.
- Comes with time signal to PSD conversion toolset (TIME2PSD), which is a powerful conditioning and conversion tool for converting multi-channel, multi event time domain data into a direct and cross PSD matrix of loading.
- Comes with a time signal generation toolset (Load Scheduler) for generating time based loading from existing RPC or CSV files with or without additional loading from block loading, deterministic waves (i.e. sine, square, triangle, sawtooth), sine sweeps, XY pairs, etc. The defined loading can be exported as separate Events in RPC / RSP / CSV / TXT or TABLED1 (BDF) format.
- Can do spot and seam weld analysis in both time domain and frequency domain. Additionally, can do User specified weld shapes in frequency domain.
- Can be used for both high-cycle fatigue and low-cycle fatigue.
- Can be used with both stress life (S-N) and strain life (e-N) material data in the same analysis.
- Comes with modifiable materials database with comprehensive set of S-N, E-N, Cyclic and component curves.

Patran

Complete FEA modeling solution

Patran is the world's most widely used pre/post-processing software for Finite Element Analysis (FEA), providing solid modeling, meshing, analysis setup and post-processing for multiple solvers including MSC Nastran, Marc, Abaqus, LS-DYNA, ANSYS, and Pam-Crash. It is a comprehensive pre- and post-processing environment for finite element analysis, helping engineers to conceptualize, develop and test product designs. Used by the world's leading manufacturing companies as their standard tool for the creation and analysis of simulation models, Patran links design, analysis, and results evaluation.

Patran provides a rich set of tools that streamline the creation of analysis ready models for linear, nonlinear, explicit dynamics, thermal, and other finite element solutions. From geometry cleanup tools that make it easy for engineers to deal with gaps and slivers in CAD, to solid modeling tools that enable creation of models from scratch, Patran makes it easy to create FE models. Meshes are easily created on surfaces and solids alike using fully automated meshing routines, manual methods that provide more control, or combinations of both. Finally, loads, boundary conditions, and analysis setup for the most popular FEA solvers is built in, minimizing the need to edit input decks.

Patran's comprehensive and industry tested capabilities ensure that your virtual prototyping efforts provide results fast so that you can evaluate product performance against requirements and optimize your designs.

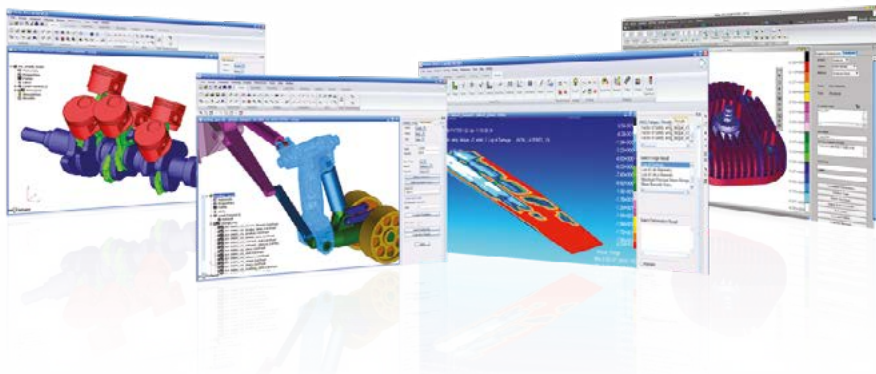

Capabilities

- Use an intuitive graphical interface with direct access of CAD geometry with automatic/interactive feature recognition
- Access multiple MSC Software and third-party solvers
- Utilize robust automatic surface and solid mesh generation with advanced surface mesh-on-mesh capability
- Model connectors and bolts with pre-loads
- Easily define full 3D general contact scenarios for nonlinear analyses
- Optimize your designs by setting up
- MSC Nastran optimization tasks
- Define superlements to analyze large FE models
- Create coupled analysis cases for Marc
- Use numerous post-processing tools to review your results
- Implement results standardization through results templates
- Customize your user interface through Patran Command Language (PCL)

Benefits

- Increase productivity of your design and development process
- Reduce development costs through increased use of simulation technologies
- Improve productivity and accuracy with multidiscipline analysis and optimization

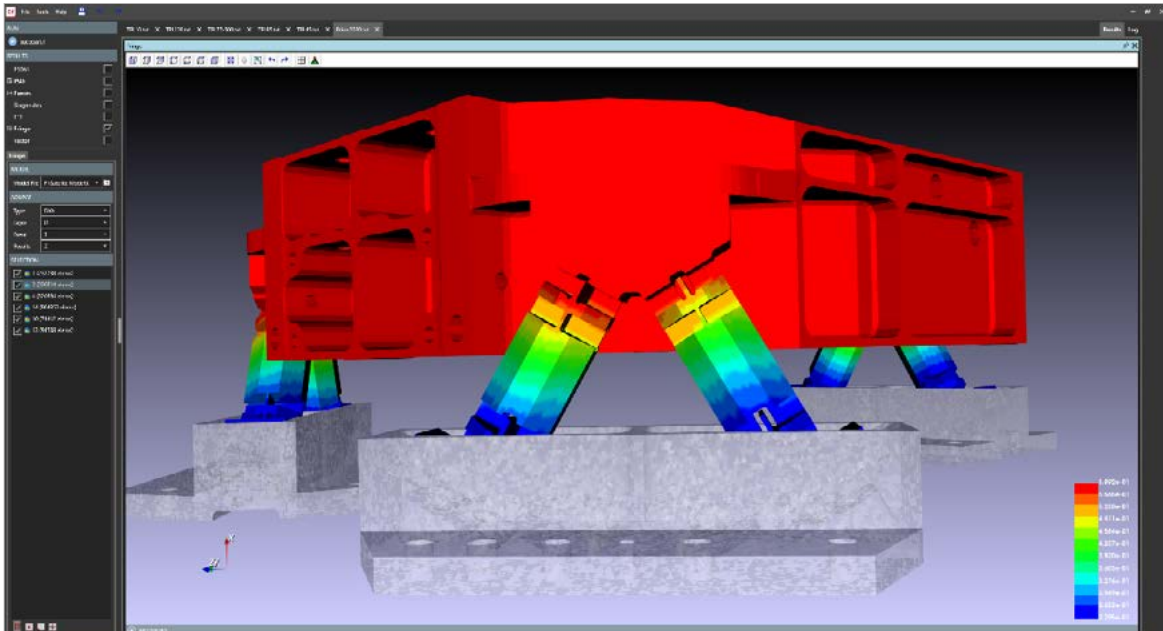

MSC Fatigue

Patran works in conjunction with MSC Fatigue to provide comprehensive durability results for your assessment. MSC Fatigue is an FE-based durability and damage tolerance solver, and can deal with the full range of fracture and fatigue life calculations for static and dynamic problems in both the time and frequency domain.

Testing against repeated loading cycles, sometimes millions of times over, is often too expensive and time-consuming to be practical. Finite element analysis programs can tell you where stress “hot spots” exist, but on their own can’t tell you whether those hot spots are critical areas for fatigue failure, or when fatigue might become a problem.

CADLM

Design space optimization with ODYSSEE

Computer-aided engineering simulation insights can be expanded dramatically with Artificial Intelligence, Machine Learning and Reduced Order Modelling. ODYSSEE from CADLM is a unique and extremely powerful software platform that connects to all of MSC's simulation software as point solutions or in multiphysics toolchains.

ODYSSEE accelerates product design and development via real-time parametric simulations with optimization, machine learning and AI tools. It employs algebraic or machine learning solutions for reducing the volume of data while preserving the most important parts of the information contained within that data. This is commonly done via decomposition or machine learning or other efficient data fusion techniques. Such techniques allow for creating on-board and real-time applications based on existing experimental or simulation results. Typical applications are optimization, parametric sensitivity analysis and robustness.

ODYSSEE is a powerful portfolio of modules (Lunar, Quasar and Nova) from our partner CADLM. It is a unique and powerful CAE-centric innovation platform that allows users to apply modern Machine Learning, Artificial Intelligence, Reduced Order Modelling (ROM) and Design Optimization to workflows.

ODYSSEE is applicable to all industrial design problems. Our main customers are from Automotive, Aerospace, Energy, Biomechanics, Defense, Motorsport, Software and physics independent, it works with Structural, Thermal, CFD, Acoustics (MSC Nastran, Marc, Adams, Cradle CFD, Actran).

ODYSSEE.Lunar

Real-time parametric design and optimization

With Lunar, you can manage the main steps of your project in real time with parametric design and optimization based on very few simulations.

- Concept design: Parametric studies, trial and error
- Detailed modeling: Optimization, model fitting
- Validation: Reliability studies, robustness

ODYSSEE includes

- Machine learning & AI
- Statistics, data mining, data fusion
- Optimization and robustness
- Process discovery
- Image recognition and compression

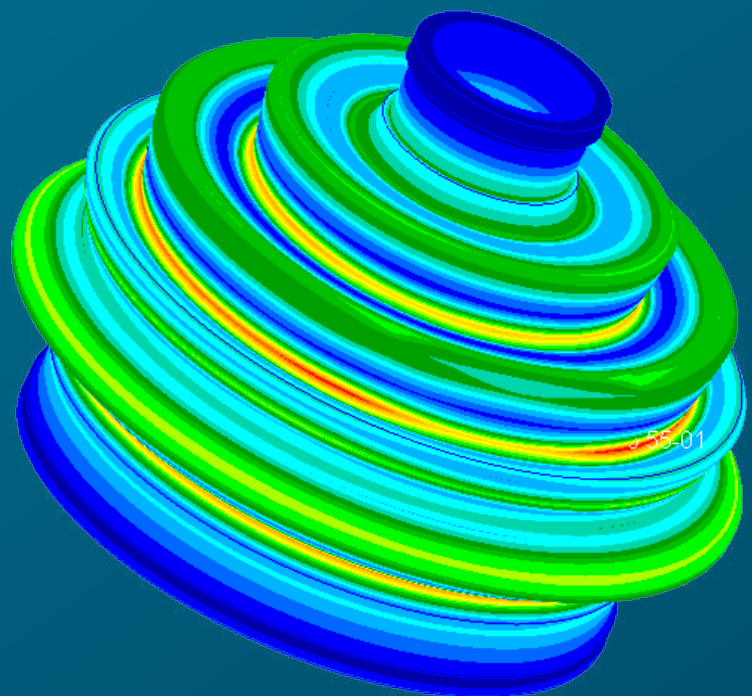

SmartUQ

Predictive analytics software for working in the uncertain world

SmartUQ is a powerful predictive analytics and uncertainty quantification (UQ) software tool that incorporates real world variability and probabilistic behavior into engineering and systems analyses. It was built from the ground up to solve some of the most challenging analytics problems faced by manufacturing companies. In industries like Automotive, Aerospace & Defense, Turbomachinery, Heavy Equipment, Medical Device, Semiconductors, Energy, Oil & Gas, Heating, Ventilation, and Air Conditioning and Consumer Products, SmartUQ software has saved our customers millions of dollars and thousands of hours of work.

Benefits

- Reduce duration of simulation and testing
- Catch problems early, reducing development time
- Prevent unnecessary design iterations
- Decrease Costs
- Increased utility of simulations
- Fewer tests & prototypes
- Reduce cost associated with unexpected failures
- Improve Quality and Reduce Risk
- Validate that the simulation agrees with reality
- Maximize Product Reliability and Durability
- Meet oversight requirements (FAA, FDA, DoD)

Capabilities:

- **Modern design of experiment** tools designed to efficiently collect data from simulation, physical testing, or digital twins.
- **Unique data sampling** tools for subsampling or dividing large data sets into evenly distributed batches for building large-scale machine learning models.
- **Flexible predictive modeling and machine learning** tools to cover a wide range of scenarios including high dimensional problems, large sample sizes, spatial data, and functional/transient responses.
- **Statistical calibration** tools to determine model calibration parameters even with limited simulation and test data and provide model discrepancy to improve simulation and perform model validation.

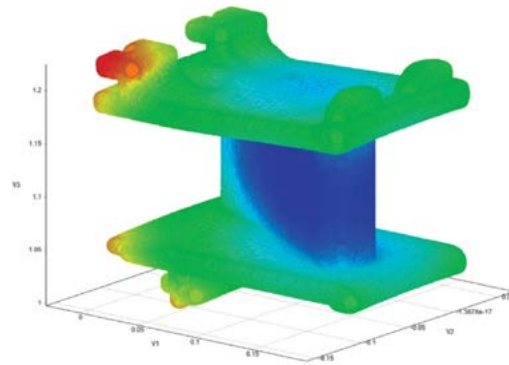

- **Inverse analysis** tool to calculate the probability distribution of inputs based on a set of outputs from a system, helping verify hard-to-measure system properties.
- **Sensitivity analysis** library to rapidly determine which factors have a relatively low or high impact on the outputs, allowing engineers to focus efforts appropriately.
- **Optimization library** handles multiple objectives and accommodates very large numbers of inputs.

Easy-to-use software

- **User-friendly GUI** Powerful, yet intuitive, SmartUQ is designed for Engineers and Data Scientists alike. SmartUQ's clean, straightforward user interface, including software wizards, makes performing complex analyses easier than ever before.
- **Integration** Analytics software is only as powerful as it is compatible with other systems. SmartUQ has built-in integrations with MSC Software products like Adams, Digimat and NASTRAN. Additionally, with SmartUQ's application programming interface (API), you can seamlessly integrate SmartUQ tools into your workflow. SmartUQ's API significantly reduces time spent on performing analyses while still providing the full benefits of its GUI.
- **Automated predictive modeling** With an existing data set or a connected simulation model, SmartUQ runs, builds, and compares predictive models until it meets your accuracy requirements.

SimManager

Simulation process and data management

SimManager is a unique Simulation Process and Data Management (SPDM) system that manages all aspects of CAE simulation. It is focused on meeting the sophisticated data management and processing needs specific to the simulation community. Our customers appreciate our deep understanding of CAE issues and how insights gained from experiences can be captured using SimManager to help them achieve higher efficiency. MSC Software provides a complete solution that brings together people, process, and technology to streamline simulation operations.

SimManager is a web-based simulation data and process management system that manages all simulation data and processes from project initiation through final report generation. Using SimManager, simulation operations become more productive and effective, reducing the cost and time it takes to bring better products to market. Effective implementation also helps meet the required certification requirements where needed, and storage and recovery of data when needed in a secure manner.

Competitive advantages that scale from a small workgroup to company-wide use include:

- Increased productivity
- Improved quality
- Standardization and establishment of best practices
- Effective collaboration
- Integrated teamwork
- Shorter product development times
- Accelerated process and product innovation
- Data traceability



Process management and automation

- Automation reduces manual execution of intensive, repetitive simulation tasks and processes
- Work request and workflow notification keep projects on track and enable management oversight
- Dashboards enable quick evaluation of studies and scenarios relative to design targets
- Built-in job queue interface optimizes execution of simulation processes and solver runs
- Simulation processes, input and output are documented via Audit Trail
- Open support of tools and applications, including MSC, 3rd party, and in-house applications
- Leverages existing hardware and software infrastructure
- Web-based configuration enables fast deployment

Enterprise integration

- Integrated access to SimManager from MSC applications
- Web-browser access to 3rd party simulation applications and other popular engineering tools
- PDM integration using PROSTEP OpenPDM technology
- Integration with Requirements Management systems
- Fully compatible with job queuing and submission systems including MSC Analysis Manager, LSF, Sun Grid Engine, and PBS Pro
- Test Data integration and comparison

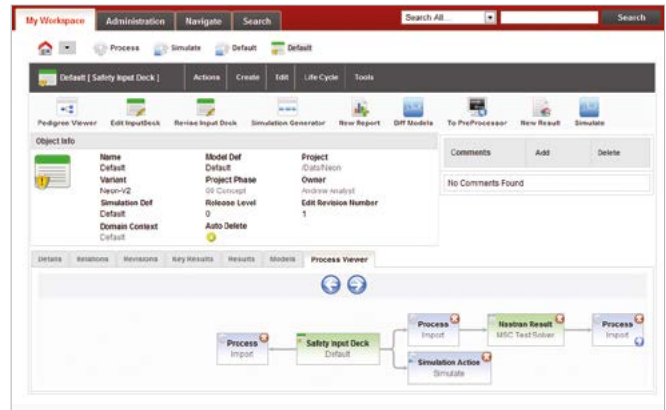

MaterialCenter

Materials lifecycle management

MaterialCenter is a Materials Lifecycle Management System designed to link material specialists to mechanical simulation. MaterialCenter captures data from integrated processes to ensure full traceability across the enterprise and throughout the product lifecycle. It addresses unique process and data requirements, and drives product innovation in complex materials such as alloys, elastomers, plastics, composites, and many more. MaterialCenter works directly with many commercial CAE products and delivers on-demand commercial databanks to engineers across the industry.

Drawn from the collective experience of the world's largest OEMs, MaterialCenter is the single point of entry for all materials related activities including physical test data entry and reduction, multi-scale materials modeling, approval workflow and the export of simulation ready data to analysis. This guarantees that engineers are using a consistent source of approved materials derived from traceable integrated processes, resulting in improved simulation fidelity, reduced data loss and elimination of tedious manual data management activities.

Reducing development time and cost of composites materials is on the main agenda for all organizations to remain competitive and to penetrate markets. A powerful tool to achieve that is Integrated Computational Materials Engineering – or in simpler words – simulation to predict and virtually test composite materials. Furthermore, when organization apply this method they quickly realize the amount of data that needs to be captured and validated, both virtual (ICME) and physical data for validation. A new innovative product integration between MaterialCenter and Digimat can enable this methodology and solve key challenges in this area.

Using MaterialCenter – a powerful data management solution, and Digimat VA – Virtual materials simulation and prediction solution – together, creates a powerful combination to not only apply ICME to reduce costs and development time by reducing amount of physical tests, but also solving a key challenge in the industry to manage the vast amount of data generated and enable comparison, analysis and validation. For example, qualification of materials will always require physical testing to be conducted, along with simulations. With this powerful integration of 2 products, comparing both sets of data, keeping traceability and connection, and enabling comparison of properties of both physical and simulation is made effortless.



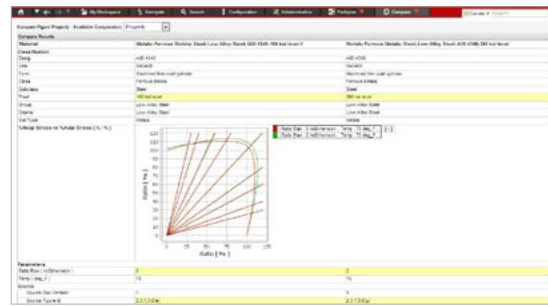

Capabilities

- Dashboards for quick evaluation of materials data management projects and management oversight
- Work request and approval workflow to keep projects on track
- All materials-related processes, input and output are documented via Audit Trail
- Process-oriented, automation approach to data management implemented to minimize manual data entry activities
- Robust and intuitive interface for data search, retrieval and comparison for all data types – tabular, curves, images, etc.
- Web-based interface to data management processes enables distributed data authoring and maintenance
- Built-in job queue interface optimizes execution of materials simulation processes

- Integration with Excel, Digimat, and 3rd party applications that support materials data processing PDM integration using PROSTEP OpenPDM technology
- Auto-capture of all data transactions
- Web-based configuration that enables fast deployment
- Configurable to support multiple global locations

Benefits

- Fast deployment and lower IT support costs
- Reduced data related inefficiencies through use of consistent source of approved materials derived from traceable integrated processes
- Rapid deployment methodology to ensure immediate productivity gains
- Scalable solution that adapts to changing organizational needs and results in lower maintenance and IT costs

10xICME solution

The 10xICME (Integrated Computational Materials Engineering) solution will help you save millions of dollars in the material development process. It has been devised to address both business and engineering challenges in the materials development and utilization process. Developed in collaboration with global OEMs and material suppliers, 10xICME is applicable to a wide range of materials, including plastics, composites, ceramics and manufacturing processes, such as injection moulding, automatic fiber placement and additive manufacturing. We shoot to deliver ROIs of 10x productivity, 10x quality, 10x cost savings and 10x time-to-market.

Virtual Test Drive (VTD)

Complete tool-chain for driving simulation applications

VTD is the world's most widely used open platform for the creation, configuration, and animation of virtual environments and scenarios for training, testing, and validation of ADAS and Autonomous Vehicles. It provides a modular tool-set for road network creation, scenario definition, vehicle dynamics, traffic and sound simulation, simulation control, image generation, sensor perception, etc. to create a digital reality for complex driving scenarios. VTD is a software package with over twenty years of existence in the market and it is in service at numerous installations in the automotive, aerospace and railroad industry worldwide, with applications in mining, farming, and shipping. It can be used in MiL, SiL, HiL, DiL, and ViL applications. Recent advances in VTD have allowed it to do massive scaling of scenarios on the Cloud thus helping in 'edge case' detection. This is done by analyzing millions of scenarios with thousands of parallel processes allowing for billions of virtual test miles to be done faster than real-time simulation, enabling an increased speed of deployable for ADAS and AD systems.

VTD helped define and uses open standard files from OpenDRIVE, OpenCRG, and OpenSCENARIO:

- OpenDRIVE is the leading global open format and the de-facto standard for the description of road networks in driving simulation applications.
- OpenCRG is the leading open-source data format and tool-suite for the creation, management, and evaluation of detailed road surfaces.
- OpenSCENARIO is the state-of-the-art open format for the definition of dynamic behavior in simulated road networks.

VTD's Road Designer (ROD) is an interactive road network editor, which is/can be used as the basis for 3D world creation. It consists of extensive libraries of 3D objects and textures representing different countries, and it provides for the creation of either complete databases or elemental building blocks (so-called 'tiles').



Capabilities

Sensors

- Simplified perfect sensors that provide object list while high fidelity sensors provide raw data like images and point clouds
- Sensors are used for road mark detection
- SDK for customization of sensor models

Pedestrian

- The capability of deterministic behavior of pedestrians on a defined path
- Pedestrians moving in more significant numbers autonomously in the road network while interacting with the system in the test (e.g., pedestrian looking at the vehicle, coming towards the vehicle)

Scenarios

- Simulations from simple maneuvers to complex urban situations with 200+ participants
- Scenarios may be retrieved from real world measurements or are completely artificial

Vehicle Model

- Model development with “to the scale” with a precision of millimeters deflections for all modes of transport ranging from Scooters to trains and helicopters
- Capabilities to build the models from a photograph with a minor offset

Weather

- Variations of time-of-day, clouds, visibility, precipitation

Traffic Model

- Simulation of independent, intelligent agents that each can act either autonomously or in deterministic mode

Massive Scaling

- Analysis of thousands of scenarios in parallel to detect edge cases
- PDM integration using PROSTEP OpenPDM technology
- Auto-capture of all data transactions
- Web-based configuration that enables fast deployment
- Configurable to support multiple global locations

Benefits

- Native support for OpenDRIVE®, OpenCRG®, and OpenSCENARIO®
- Extremely modular and scalable via its network interfaces
- Can be integrated on any platforms (MiL, SiL, DiL, ViL, HiL)
- Contains accurate sensor models (object-list based and physics-based); customizable via SDK
- Generates high-quality images (PBR technology); customizable via SDK
- Contains various libraries of 3D models and country-specific signs/signals databases
- Enables the simulation of complex traffic situations
- Easy data monitoring and injection in real-time through GUI or command lines
- Operable from a single computer up to a full-scale HPC environment
- Couple to other Hexagon AB solutions like Adams Real Time for accurate sensor modeling in vehicle dynamics
- Takes data from Hexagon’s Leica Geosystems cameras
- Edge case detection among a thousand scenarios and cloud base support

FTI – FormingSuite®

Provider of smart costing and early feasibility solutions for the sheet metal industry

FTI is the industry standard technology for Cost Engineering, Material Utilization, Process Planning, Design for Manufacturability (Evaluate BIW and Class A Panels Formability and Quality) and Stamping Simulation for Sheet Metal Components. Within the powerful FormingSuite environment FTI provides the following software solutions:

- COSTOPTIMIZER® Professional for cost engineering,
- COSTOPTIMIZER® Advanced for early feasibility, and
- FormingSuite® Professional for robust stamping simulation for sheet metal components (Virtual Manufacturing).

FTI also offers CAD integrated solutions for cost engineering and early feasibility.

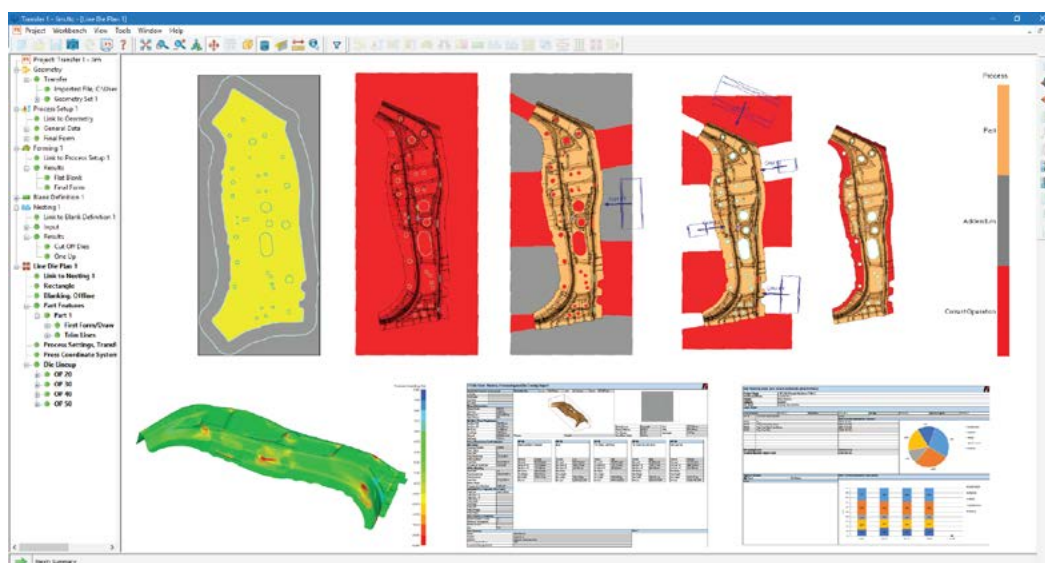

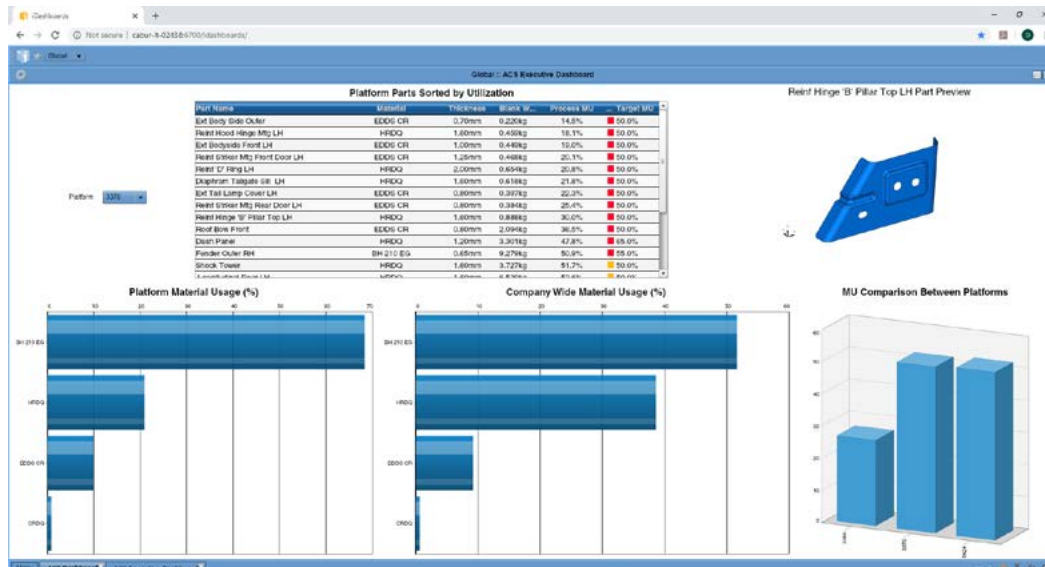

Capabilities

- Intelligently and automatically address the material cost improvement areas for management and engineers to work as a team, to improve material utilizations and reduce material spend
- Identifies product design changes that improve quality, material utilization, and reduce weight and costs for optimal material usage
- Scientific physics-based approach identifies formability issues at product design stage reducing ECOs
- Accurately identifies splits and wrinkles using Forming Limit Diagram (FLD), Safety Zone in addition to Thickness Strain, Major/ Minor Strain, etc.
- Calculates Springback to predict issues for tooling and provide information for Tolerance Negotiation and provides compensation data
- Establishes target cost for piece price and tooling with a detailed process plan for quoting
- Calculates press requirements such as tonnage, bed size, shut height, energy, and selects appropriate press
- Powerful stamping analysis package for blank development, process design validation, and virtual prove-out using both incremental and coupled hybrid inverse stamping simulation

Benefits

- Provide a holistic enterprise solution automatically to intelligently identify areas for improvement and optimization strategies for sheet metal costing at the whole vehicle level
- Addressing Design for Manufacturing issues early in the design phase to reduce engineering changes resulted from formability issues downstream, and reduce the overall time to market
- Perform accurate quotations in less than half the time using “FTI Technologies” enabling a cost engineer to perform over 2000 quotes per year
- Reports for customer technical review can be produced simultaneously with the quote to include blank layouts, feasibility simulations, and tool process description with pictorial layouts and cost breakdowns for Tool Value Analysis
- Instantaneous feedback for equipment requirements including press tonnage and bed sizes so early capacity planning can be carried out to establish maximized equipment utilization of current and new requirements well ahead of time.
- Consistent and repeatable method for estimating tooling costs with detailed reports that connect to any system
- Seamlessly integrated tools provide simulation and validation of the entire process from quoting to tooling design to virtual prove-out with speed and efficiency in a simple and intuitive user interface.



Global engineering services

Working with you to deploy and deliver certainty in CAE simulation

Industry experience

The MSC Global Engineering Services organization is a team of engineers and scientists with expertise across a wide range of engineering disciplines and industries. MSC has a 50-year history of real world hands-on practical experience with thousands of years of support experience to help you be successful with CAE.

Engineering expertise you can trust

If you want results you can trust and the flexibility of working with extremely skilled engineers who know Computer Aided Engineering (CAE) and how it's applied to engineering problems like yours, MSC is a team you can rely on to improve your product development process.

The MSC Global Engineering Services team helps companies in a variety of ways:

- Quick start projects
- Knowledge transfer
- Mentoring; on-site or over the web
- Staff augmentation
- On-site support
- Simulation projects
- Customization and process automation
- Methods development
- Solution toolkits
- Simulation process and data management
- Training

Flexible services offerings

We provide consulting support based on your specific needs and requirements.

This could range from performing analysis for you on a project basis; one or two times a year, or providing full time staff members to help you create repeatable processes in-house.

You can depend on the MSC global engineering services staff to:

- Save you time
- Automate your CAE processes
- Perform project-based simulations
- Train your staff
- Mentor and support your staff
- Correlate and validate CAE results with test data
- Transfer knowledge

For more information contact: info@mscsoftware.com

Training

MSC Software courses are designed to provide you with exclusive product knowledge. Our course developers and instructors work with product developers to gain exposure to new product capabilities. This unique insight is shared with you through official courseware that incorporates the most useful tips and techniques. When it comes to quality instruction in a classroom setting, you can trust MSC Software. Whether you're a student looking to advance your career or start a new one, or a team leader looking to make sense out of new technology, you're virtually guaranteed to find a course that will best suit your training requirements. We offer a variety of Standard Courses as well as Custom Courses, held at either an MSC training facility or at the customer's site.

Flexible training offerings

To further meet your specific requirements, we offer the following options for live instruction.

- Public classroom training – Choose from our wide selection of courses conveniently offered at sites throughout the world.
- Public online training - The convenience of on-line learning with the interactivity and depth of a traditional classroom setting – no travel required. The entire instructor-led course is live and online on your own computer. Live Online Training is an efficient, cost effective and convenient way to gain skills in the use of our MSC simulation software.
- Training at your facility – If you have a number of employees who need training, we offer the cost-effective option of bringing our class to your facility. This eliminates employee travel costs, minimizes time away from work, and can be arranged at your convenience.
- Custom courses – If our standard seminar offerings do not meet your training requirements, MSC can develop a course or set of courses tailored to your specific needs. A custom course might include a combination of topics from several standard courses or specialized material not found in any of our standard seminars.

MSC can deliver custom and private courses live or via the web. We can also help ensure that you have the adequate hardware and software licenses available for private courses. Please refer to the MSC Software training website for detailed course descriptions and dates offered at sites throughout the world.

Visit [mscsoftware.com/training](https://www.mscsoftware.com/training) to access our Global Training Schedule.

MSC Learning Center

MSC Learning Center for eLearning – MSC offers several training courses in an interactive format with audio from subject matter experts. With the complete training content that includes lectures, workshops, demos, and workshop review questions in a format that you can complete in a self-paced and self-directed manner, you can keep up and improve the simulation skills helpful to your work.

Visit www.mscsoftware.com/msc-learning-center to access our training courses.







Hexagon is a global leader in sensor, software and autonomous solutions. We are putting data to work to boost efficiency, productivity, and quality across industrial, manufacturing, infrastructure, safety, and mobility applications.

Our technologies are shaping urban and production ecosystems to become increasingly connected and autonomous – ensuring a scalable, sustainable future.

MSC Software, part of Hexagon's Manufacturing Intelligence division, is one of the ten original software companies and a global leader in helping product manufacturers to advance their engineering methods with simulation software and services. Learn more at [mscsoftware.com](https://www.mscsoftware.com). Hexagon's Manufacturing Intelligence division provides solutions that utilise data from design and engineering, production and metrology to make manufacturing smarter.

Learn more about Hexagon (Nasdaq Stockholm: HEXA B) at [hexagon.com](https://www.hexagon.com) and follow us [@HexagonAB](https://twitter.com/HexagonAB).